

Standard Radio System Plan

**REQUIREMENTS FOR TRUNK RADIO
SYSTEMS (TRS) OPERATING IN THE
FREQUENCY BAND 806 MHz TO 821 MHz AND
851 MHz TO 866 MHz**



Suruhanjaya Komunikasi dan Multimedia Malaysia

Malaysian Communications and Multimedia Commission

Off Persiaran Multimedia,

63000 Cyberjaya, Selangor Darul Ehsan, Malaysia

Tel: +60 3 8688 8000 Fax: +60 3 8688 1005

Website: www.skmm.gov.my

TABLE OF CONTENTS	PAGE
1.0 GLOSSARY	3
2.0 INTENT	4
3.0 GENERAL	4
4.0 CHANNELLING PLAN	8
5.0 REQUIREMENTS FOR USAGE OF SPECTRUM	9
6.0 PRINCIPLES OF ASSIGNMENT	10
7.0 IMPLEMENTATION PLAN	12
8.0 CO-ORDINATION REQUIREMENT	12
9.0 REVOCATION	13
10.0 REFERENCES	13
APPENDIXES	
APPENDIX A: Table of Frequency allocation in 806-821MHz and 851-866MHz	15
APPENDIX B: Trunked Radio System Channelling Plan (Block A, 25 kHz)	18
APPENDIX C: Trunked Radio System Channelling Plan (Block B, 25 kHz)	19
APPENDIX D: Trunked Radio System Channelling Plan (Block C, 25kHz)	20
APPENDIX E: Channel Allotment Plan for Block A, B and C	21
APPENDIX F Summary of Spectrum Allocation for Mobile Radio Services	23
APPENDIX G: List of Existing Analogue TRS Service Provided	26
APPENDIX H: Conditions for Issuance of Apparatus Assignments in Block A and B	27
APPENDIX I: Interference Resolution Process	28

1.0 GLOSSARY

- 1.1 The terms used in this document may be found in the document SRSP Glossary which can be downloaded from the SKMM website.
(http://skmm.gov.my/link_file/what_we_do/spectrum/pdf/srsp/SRSPGlossary.pdf)

REQUIREMENTS FOR TRUNKED RADIO SYSTEMS (TRS) OPERATING IN THE FREQUENCY BAND 806 MHz TO 821 MHz AND 851 MHz TO 866 MHz

2.0 INTENT

- 2.1. This Standard Radio System Plan (SRSP) states the requirements for the utilisation of the frequency bands between 806 MHz to 821 MHz and 851 MHz to 866 MHz for Trunked Radio Systems (TRS) in Malaysia.
- 2.2. TRS are two-way mobile radio systems consisting of mobile terminals, multiple-channel base stations and control stations. Trunking is the pooling of radio channels of a TRS, whereby users have automatic access to all channels of the system. TRS may also have roaming capabilities and may have Direct Mode Operation between mobile terminals.
- 2.3. The intended services include transmission of voice, data, image, paging, short messaging, facsimile and PSTN interconnection for such users as transport companies, service and maintenance companies, airline services and Government agencies. Users of these frequencies may be operators of public TRS networks as well as private organisations/corporation or government agencies. Operation of TRS may be area based or nation-wide with roaming capabilities.
- 2.4. In general, this SRSP is designed to provide information on the minimum requirements in the use of the frequency bands as described in the Malaysian Table of Frequency Allocation (see **Appendix A**). It provides information on technical characteristics of radio systems, frequency channelling, coordination initiatives in order to maximise the utilisation, minimise interference and optimise the usage of the band. It is intended to regulate the usage of spectrum and does not attempt to establish any detailed equipment standards.

3.0 GENERAL

- 3.1. Technical characteristics of equipment used in TRS shall conform to all applicable Malaysian standards, international standards, International Telecommunications Union (ITU) and its radio regulations as agreed and adopted by Malaysia.
- 3.2. All TRS installations must comply with safety rules as defined by applicable standards.
- 3.3. The equipment used shall be certified under the Communications and Multimedia (Technical Standards) Regulations 2000.
- 3.4. The allocation and allotment of these frequency bands and this SRSP are subject to review from time to time in tune with new industry developments, technical or non-

technical for more efficient utilisation and management of spectrum, or for the improvement of the services offered by such systems.

- 3.5. TRS operating in the frequency bands 806-821 MHz and 851-866 MHz were first introduced in Malaysia in 1990. Prior its introduction, earlier two-way radio repeater systems known as Leased Channel Systems consist of radio channels working independently of one another. A mobile terminal using such a system does not have access to channels other than the channel to which it is assigned. Traffic throughput per channel of such systems is much lower than that of TRS and spectral efficiency is lower.
- 3.6. Leased Channel Systems in Malaysia operate in the 200 MHz and 400 MHz frequency bands. These systems are gradually being replaced by the more spectrally and functionally efficient TRS.
- 3.7. With the advent of digital TRS, Malaysia now has a complimentary set of public system technologies, from single-frequency repeaters to digital trunking, such as iDEN, TETRA, APCO25, GSM-R, GSM-T and Go Ta CDMA. SKMM, has laid out in the Spectrum Plan, and expects operators to migrate toward digital solutions in the congested areas, and re-deploy the older technologies to provide niche market service and service in the remote areas that might not otherwise receive adequate TRS coverage.
- 3.8. The following sections will give an overview of some digital TRS technologies available in the industry.

3.8.1 TETRA

TETRA (Terrestrial Trunked Radio) is a set of technology solution developed by the ETSI that describes a common mobile radio communications infrastructure throughout Europe. It is targeted primarily at the mobile radio needs of public safety groups (such as police and fire departments), utility companies, and other enterprises that provide voice and data communications services. All of these groups have been high-end users of private/professional mobile radio (PMR) or public access mobile radio (PAMR) technology.

Employing TDMA digital trunked radio technology, TETRA is one of the next-generation digital standards for two way radio communications. TETRA actually takes its features from several different communications fields: mobile radio, digital cellular telephone, paging, and wireless data. TETRA-based products are available with options for encryption to ensure the privacy and confidentiality of sensitive data/voice communications.

The TETRA market is segmented into three distinct categories - Emergency Services, Private Systems, and Public Network Services. ETSI is developing an enhanced family of TETRA standards generally referred to as TETRA Release 2. This is expected to provide data rates of up to 130 kbps (kilobits per second), compared to current TETRA data rates of 7.2 kbps.

3.8.2 iDEN

iDEN (Integrated Digital Enhanced Network) is digital trunked radio technology for wide area despatch from Motorola that operates in the traditional 800 MHz band and is based on time division multiple access (TDMA). The technology allows for very effective use of the spectrum – with a usage improvement of almost 6 to 12 times the current analogue despatch network.

iDEN network and handsets are designed to provide the trunked radio user with digital wireless technology that feature robust applications and integrated solutions. Users on the iDEN network have the ability to do wide area secure private despatch (effectively covering Malaysian land mass), group despatch amongst pre-defined clusters, telephone interconnect, SMS and packet data applications.

3.8.3 APCO25

The Association of Public-Safety Communications Officials International Inc. (APCO) has completed a standard for digital trunked radio systems. This is an open standard and based on FDMA modulation. The Standard defines both trunked and conventional modes of operation, and requires equipment to be backward compatible to analogue 25 kHz and 12.5 kHz channel spaced systems. Options are included for encryption to ensure voice security

APCO Project 25 ensures that equipment built to the Standard will communicate with other equipment from different manufacturers. By building an APCO Project 25 standards based system, it assures inter-operability, allows for more potential equipment suppliers which in turn increases the competition, which in turn helps drive equipment costs down.

APCO 25 is co-chaired by APCO International and the National Association of State Telecommunications Directors (NASTD). The steering committee, which makes the decisions, consists of APCO International and NASTD representatives, along with federal representatives from the National Telecommunications and Information Administration (NTIA), National Communications System (NCS), and the Department of Defence (DoD).

3.8.4 NXDN

NXDN is a digital air interface protocol for mobile communication. It was developed jointly by Icom Incorporated and Kenwood Corporation. This standard is based on FDMA (Frequency Division Multiple Access) and defines both trunked and conventional modes of operation. NXDN is a digital radio communications protocol using 4-Level FSK (4LFSK) modulation capable of fitting into both 12.5 kHz and 6.25 kHz physical radio channel bandwidth (9600 bps and 4800 bps respectively).

3.8.5 GSM-R

GSM-R technology was developed in an European Union - funded MORANE (Mobile Radio for Railways Networks in Europe) project. The project's goal is to develop a uniform digital radio system for European railroad traffic. GSM-R is a

platform for voice and data communications as well as for traffic control system (ETCS, Electronic Train Control System).

After comparing the different digital technologies, Global System for Mobile (GSM) technology was chosen by the 32 railway companies involved in the project. GSM was extended with special features developed for rail traffic. As they are closed networks, it is possible to build special applications needed for the railroad environment.

GSM-R is used for traffic control, serving amongst others engine drivers as well as personnel working on railroad works both along the rail network and in railway stations. The system ensures a more secure and smooth flow of train traffic.

GSM-R is currently being introduced as the European standard for railway communications and is already in commercial use in several European countries. This allows for a single international communication standard for train communication and also improves interoperability between the various railway companies at international level.

3.8.6 GSM-T

The GSM Trunking system (GSM-T) operating at 800MHz is a Huawei solution in expanding the GSM-R platform to the land-based trunked radio and is oriented to addressing industry specific dispatching requirements. It is applicable to both private and public networks.

3.8.7 Go Ta CDMA

The Go Ta CDMA system which operates in 800MHz band is a CDMA-based digital trunking system. The GoTa or “Global Open Trunking Architecture” was developed independently by ZTE to meet the requirements of both private and public trunking network applications.

- 3.9. With the advent of digital trunked radio technologies with roaming capabilities and applications such as transmission of data, image, paging, short messaging, facsimile and PSTN interconnect, provisions have been made by SKMM to address the current and future numbering and electronic addressing needs of such trunked radio networks. The numbering and electronic addressing plan has included mobile numbers for assignment to terminals of such digital trunked radio networks to ensure that digital trunked radio networks are part of a ubiquitous national infrastructure.

4.0 CHANNELLING PLAN

- 4.1 The SRSP defines the frequency bands 806 to 821 MHz paired with 851 to 866 MHz providing a total bandwidth of 2 x 15MHz for Trunked Radio Systems (TRS). The channel arrangements are divided into 3 pairs of frequency blocks (blocks A/A', blocks B/B', and blocks C/C') with transmit/receive separation of 45 MHz as shown in Figure 1.
- 4.2 The frequency channelling plans of blocks A/A', B/B' and C/C' are given in **Figure 1** below.

Figure 1: Show the frequency band for Base Transmit/Receive

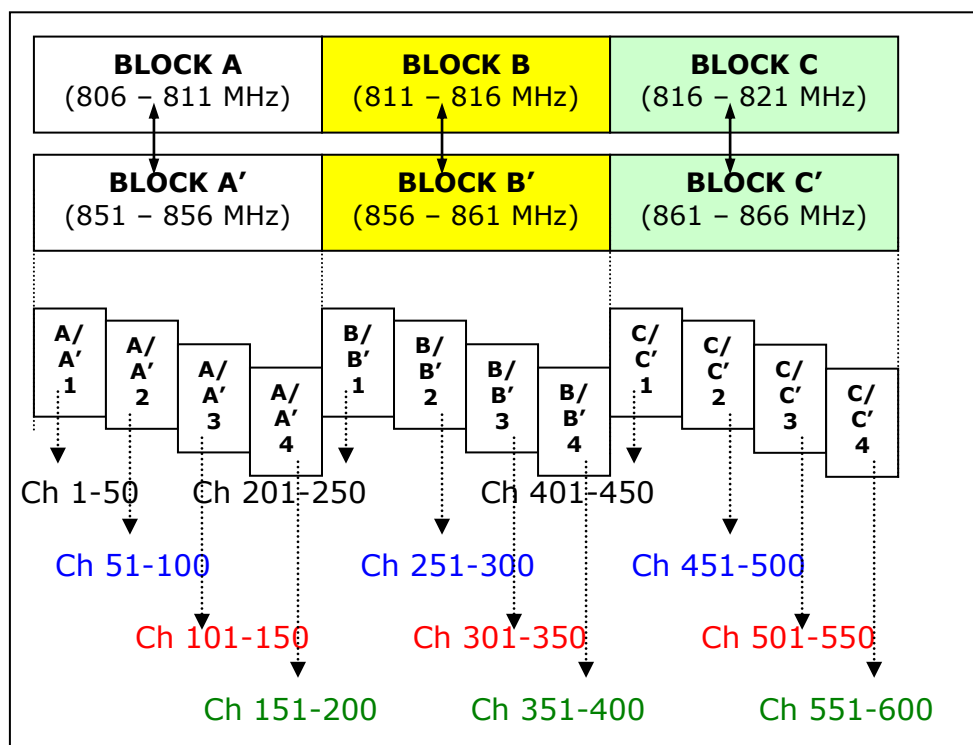

- 4.2.1 For 25 kHz channel spacing

$$f_n = (N+0.0125) + (n-1)*(0.025)$$

$$n = 1 \text{ to } 200$$

For Transmit Channels

N = 806 for Block A

N = 811 for Block B

N = 816 for Block C

For Receive Channels

N = 851 for Block A

N = 856 for Block B

N = 861 for Block C

- 4.3 Each block (Block A/A', B/B' and C/C') is divided into 4 sub blocks. Each sub block consists of 2 x 50 contiguous 25 kHz channels.

- 4.4 The channelling plan is developed based on 25 kHz channel spacing. However, the usage of channel spacing shall not be restricted to 25 kHz. The use of channel spacing less than or more than 25 kHz shall be allowed for broadband TRS systems but SKMM shall assign a single channel based on channel spacing 25 kHz or combination of multiple channels of 25 kHz channel spacing as was developed in the channelling plan above (Figure 1);
- 4.4 Flexible use of channel spacing will help spectrum users to manage their network in a more efficient manner that fit their requirement. Bigger channel spacing used will cause less channel number available and vice-versa; smaller channel spacing used will allow a spectrum user to have more channel number.
- 4.5 Currently, most of the channels in Block A, B and C (except Block C3/C3') is assigned to public operators and private network for analogue and digital trunked radio systems throughout the nation.
- 4.6 The spectrum covered by this SRSP has been channelised to accommodate TRS **that can use** either contiguous channels or non-contiguous channels that require separation between channels. This flexible arrangement is adopted to provide users with a wide choice of trunked radio solutions. However, based on whatever technology solution the service provider chooses, operation must be within the allocated channel bandwidth (including guard bands) without causing any interference to adjacent services.

5.0 REQUIREMENTS FOR USAGE OF SPECTRUM

- 5.1 This SRSP covers the minimum key characteristics considered necessary in order to make the best use of the available frequencies.
- 5.2 This SRSP is intended for the operation of analogue and digital TRS (see paragraph 4.5). Digital TRS are normally divided into Wide Area or National Coverage systems.
- 5.3 Capacity enhancing techniques are continually being developed. This SRSP allows for adoption of such techniques for more efficient use of spectrum, without reducing quality of service. Good cell-planning practice and frequency reuse should be adopted to maximise spectrum usage.
- 5.4 As technology allows for modulation schemes allowing wider (1.25 MHz) and narrower (6.25 kHz) carrier bandwidth from the existing 25 kHz channels, the number of available channels will vary.
- 5.5 Channel loading of TRS systems should be such that the maximum use is made of the available spectrum while providing reasonable grade of service. This SRSP requires the loading of public and private systems to be such as to provide a Grade of Service (GOS) not exceeding five percent (5%).

- 5.6 The GOS can be modelled on traffic theory and makes use of the Erlang C model. This model assumes that the system will queue a certain number of blocked calls. The Grade of Service will be defined by a specified delay, in message lengths, such that calls delayed will not exceed the specified delay with a probability P(t) of 0.05 (5%). That is, 95% of the calls placed will not be delayed by greater than the specified delay.
- 5.7 The GOS is critical for emergency services like Police, Fire and Ambulances as well for local government agencies. The corresponding figure for public safety systems (e.g., police, ambulance and fire department) is 2.5 percent. However, the level of GOS may be changed if deemed necessary by SKMM based on specific service requirements.
- 5.8 Public safety services (services involving safety of life and property) will continue, if possible, to have access to exclusive channels and any eventual sharing of channels by public safety services will be with other public safety services.
- 5.9 Please refer to **Appendix F** for a summary of spectrum allocation for various mobile radio services.
- 5.10 In operations within 50km from border areas, power limitation criteria shall be applicable for the following:
- Base Transmitter - Less than 50 Watts ERP
 - Mobile Transmitter - Less than 25 Watts ERP
- 5.11 The future plans and strategic issues of spectrum usage is as laid out in the Spectrum Plan and should be taken into account in the implementation of services.
- 5.12 The allocations of spectrum and shared services within these bands are found in the Spectrum Plan shown in **Appendix A**.

6.0 PRINCIPLES OF ASSIGNMENT

- 6.1 Authorisation to use the trunked radio spectrum for the **base station** apparatus is by way of Apparatus Assignment (AA) and the **trunked radio access device** is by way of Class Assignment (CA). Please refer to www.skmm.gov.my for the conditions of use in the Notification of Issuance of Class Assignment for the trunked radio access device.
- 6.2 The paragraphs below contain the eligibility, information and documents to be submitted for the AA application.
- 6.2.1 Spectrum Blocks A and B**
- 6.2.1.1 The eligibility criteria for the service providers in spectrum Blocks A and B is that the applicant must be a holder of a valid Network Facilities Provider Individual (NFP(I)) licence that provides radiocommunication transmitters and links (Note: spectrum Blocks A and B are set aside for the current analogue service providers listed in Appendix G).

6.2.1.2 The applicant shall:

6.2.1.2.1 submit a Detailed Business Plan including details of the roll out and digital migration plan acceptable by the Commission (Due to the closure of this band to TRS as indicated in paragraph 7.5, no new Detailed Business Plan shall be considered by SKMM);

6.2.1.2.2 upon the approval of the Detailed Business Plan by the Commission, submit application for an AA in accordance with the geographic areas specified in the Detailed Business Plan; and

6.2.1.2.3 prior to the issuance of the AA, provide to the Commission an Irrevocable Bank Guarantee to guarantee performance and compliance with the conditions of the AA and the Detailed Business Plan, payable on demand, either in part or in full, for the amount of RM2,600,000 (Ringgit Malaysia Two Million Six Hundred Thousand) per defined geographic area from a licensed financial institution in Malaysia in the form and substance agreed by the Commission, which shall be valid for the period of the AA ((Due to the closure of this band to TRS as indicated in paragraph 7.5 and IBG submitted before the effective date of this SRSP will be returned).

6.2.1.3 The finalised size of spectrum make available on nationwide basis to the groups/consortiums shall be based on the principle of:

6.2.1.3.1 the percentage total of analogue TRS AA held as at 31 July 2006;

6.2.1.3.2 the needs of the technology of choice; and

6.2.1.3.3 spectrum allocation efficiency.

6.2.1.4 The application for an AA shall be based on the committed roll out plan as specified in the Detailed Business Plan. For spectrum which are not utilised or under utilised or not covered by the roll out plan, SKMM may allow other NFP(I) licensees to apply for an AA.

6.2.1.5 AA issued to successful applicant shall be subject to further additional conditions specified in Appendix H.

6.2.2 Spectrum Block C

6.2.2.1 For Private and Government users, the application for AA shall be considered on a first come first served basis. In the event of unavailability of spectrum, applicants will be placed in a queue that will be reviewed periodically. Expired AA where no re-application has been made within the time specified in paragraph 6.5 will be re-assigned to others in the queue.

- 6.3 Applicants are required to:
- 6.3.1 Submit AA application for the apparatus on the prescribed AA forms.
- 6.4 The AA for these bands shall be valid for a period of five years or such lesser period as specified in the AA. AA holders may re-apply for a new assignment at least 60 days before the expiry date.
- 6.5 Issuance of an AA is also subject to successful co-ordination among assigned stations and with neighbouring countries where it applies.

7.0 IMPLEMENTATION PLAN

- 7.1 This SRSP shall be effective from the date of issuance of this document.
- 7.2 Further to paragraph 4.5 above, the current holders of AA under the analogue TRS service (as listed in Appendix G) shall facilitate the migration to digital service as follows:-
- 7.2.1 Current holders of AA under the Private and Government users are to move out of the Blocks A and B into C to be facilitated and implemented by the NFP(I) (from the existing analogue service providers as in the list in Appendix G);
- 7.2.2 Current analogue service providers are encouraged to form groups/consortiums and apply for the NFP(I) license to facilitate migration to digital service into the spectrum blocks A and B by **31 December 2008**; and
- 7.2.3 SKMM may make available the spectrum to facilitate the migration from analogue to digital, digital service planning and for the issuance of AA.
- 7.3 Installations before the effective date of this SRSP are allowed to operate without causing any interference to new installations complying with this SRSP.
- 7.4 No assignment shall be issued to TRS service providers, private and government users after **31 December 2015** in these bands.
- 7.5 Current analogue and digital trunked radio service providers and users are required to migrate out from these frequency bands to the 410-430MHz band or other identified bands by **31 December 2015**. SKMM will coordinate the process of migration, to be facilitated and implemented by the migrating current analogue and digital service providers and users.

8.0 CO-ORDINATION REQUIREMENT

- 8.1 Use of these frequency bands shall require coordination with the neighbouring countries within the coordination zones of 50 kilometres from our neighbouring countries. Note that the above coordination distance is continuously being reviewed with our neighbouring countries and may be updated from time to time.
- 8.2 Technical analysis is carried out by SKMM before an assignment is issued. Operator-to-operator coordination may be required to avoid interference.
- 8.3 In the event of any interference, SKMM will require affected users to carry out an operator-to-operator coordination. In the event that the interference remained unresolved after 24 hours by the operators, the affected parties may escalate the matter to SKMM for a resolution. SKMM will decide the necessary modifications and schedule of modifications to resolve the interference.
- 8.4 Assignment holders are expected to take full advantage of interference mitigation techniques such as antenna discrimination, tilt, polarization, frequency discrimination, shielding/blocking (introduce diffraction loss), site selection, and/or power control to facilitate the coordination of systems.
- 8.5 Coordination requirement may be required with reference to the potential interference problems as depicted in Appendix I.

9.0 REVOCATION

- 9.1 MCMC SRSP-502M, 5 September 2006 Issue is hereby revoked.

10.0 REFERENCES

- [1] CETS-R/SPC/001 Radio Performance Specifications which prescribes the minimum performance for radio communication transmitters and receivers operating primarily in a voice or data modulated mode with maximum frequency deviation of +/- 5 kHz in the allocated VHF/UHF bands in the frequency range 27.41 MHz - 866 MHz and 928 MHz - 953 MHz. It is intended to be applicable for mobile stations, base and/or repeater stations.
- [2] RSS 121 (Radio Standard Specifications): Mobile stations - Voice and data modulated FM or PM Radiotelephone transceivers operating in the allocated VHF/UHF bands in the frequency range 27.41 - 866 MHz with RF power output not exceeding 10 Watts
- [3] Spectrum Plan

- [4] SRSP-502 (Canadian) (10/1999) Technical Requirements for Land Mobile and Fixed Radio Services Operating in the Bands 806-821/851-866 MHz and 821-824/866-869 MHz
- [5] RALI: LM8 (12/2000) Frequency Assignment Requirement for the Land Mobile Service

Issued by:



Suruhanjaya Komunikasi dan Multimedia Malaysia
Malaysian Communications and Multimedia Commission

APPENDIX A: EXTRACT OF MALAYSIAN SPECTRUM PLAN

(This Appendix forms an integral part of the SRSP document)

Radio Services Sharing the Frequency Band 806 to 821 MHz and 851 to 866 MHz

Frequency Band (MHz)	ITU Allocations			Malaysian Allocations
	Region 1	Region 2	Region 3	
470 - 512	470 -790 BROADCASTING	BROADCASTING Fixed Mobile 5.292 5.293	470-585 FIXED MOBILE BROADCASTING	FIXED MOBILE BROADCASTING MLA29
512 - 585		512-608	5.291 5.298	MLA3 MLA86 MLA87
585 – 608		BROADCASTING 5.297	585-610 FIXED	FIXED MOBILE
608 – 610		608-614 RADIO ASTRONOMY Mobile-satellite except aeronautical mobile-satellite (Earth-to-space)	MOBILE BROADCASTING RADIONAVIGATION 5.149 5.305 5.306 5.307	BROADCASTING MLA29 RADIONAVIGATION 5.149 5.306 MLA3 MLA87 MLA88
610 – 614			610-862	FIXED
614 – 698		BROADCASTING Fixed Mobile 5.293 5.309 5.311A	FIXED MOBILE 5.313A 5.317A BROADCASTING	MOBILE 5.317A BROADCASTING MLA29
698 – 790	5.149 5.291A 5.294 5.296 5.300 5.302 5.304 5.306 5.311A 5.312	698-806		
790 – 806	790 – 862 FIXED BROADCASTING	BROADCASTING MOBILE 5.313B 5.317A Fixed 5.293 5.309 5.311A		
806 – 862	MOBILE except aeronautical mobile 5.316B 5.317A 5.312 5.314 5.315 5.316 5.316A 5.319	806-890 FIXED MOBILE 5.317A BROADCASTING 5.317 5.318	5.149 5.305 5.306 5.307 5.311A 5.320	5.149 5.306 5.311A 5.320 MLA3 MLA14 MLA86 MLA87 MLA88

Frequency Band (MHz)	ITU Allocations			Malaysian Allocations
	Region 1	Region 2	Region 3	
862 - 890	FIXED MOBILE except aeronautical mobile 5.317A BROADCASTING 5.322 5.319 5.323	FIXED MOBILE 5.317A BROADCASTING 5.317 5.318	FIXED MOBILE 5.313A 5.317A BROADCASTING 5.149 5.305 5.306 5.307 5.311A 5.320	FIXED MOBILE MLA79 MLA80 BROADCASTING MLA3 MLA14 MLA 44 MLA84

5.149 In making assignments to stations of other services to which the bands:

13 360-13 410 kHz,	4 950-4 990 MHz,	102-109.5 GHz,
25 550-25 670 kHz,	4 990-5 000 MHz,	111.8-114.25 GHz,
37.5-38.25 MHz,	6 650-6 675.2 MHz,	128.33-128.59 GHz,
73-74.6 MHz in Regions 1 and 3,	10.6-10.68 GHz,	129.23-129.49 GHz,
150.05-153 MHz in Region 1,	14.47-14.5 GHz,	130-134 GHz,
322-328.6 MHz,	22.01-22.21 GHz,	136-148.5 GHz,
406.1-410 MHz,	22.21-22.5 GHz,	151.5-158.5 GHz,
608-614 MHz in Regions 1 and 3,	22.81-22.86 GHz,	168.59-168.93 GHz,
1 330-1 400 MHz,	23.07-23.12 GHz,	171.11-171.45 GHz,
1 610.6-1 613.8 MHz,	31.2-31.3 GHz,	172.31-172.65 GHz,
1 660-1 670 MHz,	31.5-31.8 GHz in Regions 1 and 3,	173.52-173.85 GHz,
1 718.8-1 722.2 MHz,	36.43-36.5 GHz,	195.75-196.15 GHz,
2 655-2 690 MHz,	42.5-43.5 GHz,	209-226 GHz,
3 260-3 267 MHz,	48.94-49.04 GHz,	241-250 GHz,
3 332-3 339 MHz,	76-86 GHz,	252-275 GHz
3 345.8-3 352.5 MHz,	92-94 GHz,	
4 825-4 835 MHz,	94.1-100 GHz,	

are allocated, administrations are urged to take all practicable steps to protect the radio astronomy service from harmful interference. Emissions from spaceborne or airborne stations can be particularly serious sources of interference to the radio astronomy service (see Nos. 4.5 and 4.6 and Article 29). (WRC-07)

5.306 *Additional allocation:* in Region 1, except in the African Broadcasting Area (see Nos. 5.10 to 5.13), and in Region 3, the band 608-614 MHz is also allocated to the radio astronomy service on a secondary basis.

5.311A For the frequency band 620-790 MHz, see also Resolution 549 (WRC-07). (WRC-07)

5.320 *Additional allocation:* in Region 3, the bands 806-890 MHz and 942-960 MHz are also allocated to the mobile-satellite, except aeronautical mobile-satellite (R), service on a primary basis, subject to agreement obtained under No. 9.21. The use of this service is limited to operation within national boundaries. In seeking such agreement, appropriate protection shall be afforded to services operating in accordance with the Table, to ensure that no harmful interference is caused to such services.

MLA3 Notification of Issuance of Class Assignment.

MLA14 The following frequency bands are exclusively use by the Government of Malaysia:
30 kHz to 70 kHz; 70 kHz to 90 kHz;
110 kHz to 160 kHz; 1985 kHz to 3000 kHz;

3025 kHz to 3155 kHz;	4700 kHz to 4750 kHz;
5680 kHz to 5730 kHz;	6685 kHz to 6765 kHz;
8965 kHz to 9040 kHz;	11175 kHz to 11275 kHz;
13200 kHz to 13260 kHz;	13360 kHz to 13410 kHz;
14500 kHz to 14900 kHz,	15010 kHz to 15100 kHz;
17970 kHz to 18030 kHz;	23200 kHz to 23350 kHz;
25550 kHz to 25670 kHz;	30.010 MHz to 37.500 MHz;
41.015 MHz to 44.000 MHz;	44.000 MHz to 47.000 MHz;
47.000 MHz to 50.000 MHz;	54.000 MHz to 68.000 MHz;
72.800 MHz to 74.800 MHz;	75.200 MHz to 75.400 MHz;
75.400 MHz to 87.000 MHz;	165.000 MHz to 167.000 MHz
170.000 MHz to 172.000 MHz,	230.000 MHz to 235.000 MHz;
235.000 MHz to 267.000 MHz;	267.000 MHz to 272.000 MHz;
272.000 MHz to 273.000 MHz;	273.000 MHz to 312.000 MHz;
312.000 MHz to 315.000 MHz;	315.000 MHz to 322.000 MHz;
322.000 MHz to 328.600 MHz;	335.400 MHz to 380.000 MHz;
380.000 MHz to 399.900 MHz;	444.000 MHz to 445.000 MHz
449.000 MHz to 450.000 MHz,	457.000 MHz to 458.000 MHz;
458.000 MHz to 459.000 MHz;	467.000 MHz to 468.000 MHz;
468.000 MHz to 469.000 MHz;	798.000 MHz to 806.000 MHz;
816.000 MHz to 821.000 MHz,	861.000 MHz to 866.000 MHz
960.000 MHz to 1215.000 MHz;	1400.000 MHz to 1427.000 MHz;
2040.000 MHz to 2072.000 MHz	2035.000 MHz to 2036.000 MHz
2232.000 MHz to 2233.000 MHz;	2700.000 MHz to 2900.000 MHz;
2900.000 MHz to 3100.000 MHz;	3100.000 MHz to 3300.000 MHz;
3300.000 MHz to 3400.000 MHz;	4940.000 MHz to 4990.000 MHz;
5460.000 MHz to 5470.000 MHz;	5470.000 MHz to 5650.000 MHz;
8146.000 MHz to 8275.000 MHz;	9500.000 MHz to 9800.000 MHz;
9800.000 MHz to 10000.000 MHz.	

- MLA 44 Frequency Spectrum 806 MHz to 960 MHz, 1710 MHz to 1885 MHz, 2504 MHz to 2688 MHz planned for IMT 2000 extension band.
- MLA84 The following bands have been identified for Public Protection and Disaster Relief (PPDR) use in Malaysia:
380 MHz to 400 MHz;
816 MHz to 821 MHz / 861 MHz to 866 MHz;
4940 MHz to 4990 MHz
- MLA86 Use of the band 477 MHz to 478 MHz for short range communication devices such as personal radio service is not allowed after year 2020. This band will be re-allocated to the Digital TV Broadcasting (DTT) Service. [477 MHz – 478 MHz].
- MLA87 Existing analogue TV transmission operating in the Bands 174 MHz to 230 MHz and 470 MHz to 798 MHz may continue their service until the year 2015. However, they shall shut down their analogue transmission after year 2015. [174 MHz – 230 MHz & 470 MHz – 798 MHz]
- MLA88 Use of frequency bands 223 MHz to 230 MHz and 606 MHz to 614 MHz by the existing assignment for Airport Tower operations and Radar by Aeronautical Service are not allowed after year 2020. [223 MHz – 230 MHz & 606 MHz – 614 MHz]

APPENDIX B: 25 kHz Channel Spacing

TRUNKED RADIO SYSTEM FREQUENCY CHANNELLING PLAN (BLOCK A/A' 25 kHz)

CH. NO.	FREQ. (MHz)		CH. NO.	FREQ. (MHz)		CH. NO.	FREQ. (MHz)		CH. NO.	FREQ. (MHz)		CH. NO.	FREQ. (MHz)	
	Base Tx	Base Rx		Base Tx	Base Rx		Base Tx	Base Rx		Base Tx	Base Rx		Base Tx	Base Rx
1	806.0125	851.0125	41	807.0125	852.0125	81	808.0125	853.0125	121	809.0125	854.0125	161	810.0125	855.0125
2	806.0375	851.0375	42	807.0375	852.0375	82	808.0375	853.0375	122	809.0375	854.0375	162	810.0375	855.0375
3	806.0625	851.0625	43	807.0625	852.0625	83	808.0625	853.0625	123	809.0625	854.0625	163	810.0625	855.0625
4	806.0875	851.0875	44	807.0875	852.0875	84	808.0875	853.0875	124	809.0875	854.0875	164	810.0875	855.0875
5	806.1125	851.1125	45	807.1125	852.1125	85	808.1125	853.1125	125	809.1125	854.1125	165	810.1125	855.1125
6	806.1375	851.1375	46	807.1375	852.1375	86	808.1375	853.1375	126	809.1375	854.1375	166	810.1375	855.1375
7	806.1625	851.1625	47	807.1625	852.1625	87	808.1625	853.1625	127	809.1625	854.1625	167	810.1625	855.1625
8	806.1875	851.1875	48	807.1875	852.1875	88	808.1875	853.1875	128	809.1875	854.1875	168	810.1875	855.1875
9	806.2125	851.2125	49	807.2125	852.2125	89	808.2125	853.2125	129	809.2125	854.2125	169	810.2125	855.2125
10	806.2375	851.2375	50	807.2375	852.2375	90	808.2375	853.2375	130	809.2375	854.2375	170	810.2375	855.2375
11	806.2625	851.2625	51	807.2625	852.2625	91	808.2625	853.2625	131	809.2625	854.2625	171	810.2625	855.2625
12	806.2875	851.2875	52	807.2875	852.2875	92	808.2875	853.2875	132	809.2875	854.2875	172	810.2875	855.2875
13	806.3125	851.3125	53	807.3125	852.3125	93	808.3125	853.3125	133	809.3125	854.3125	173	810.3125	855.3125
14	806.3375	851.3375	54	807.3375	852.3375	94	808.3375	853.3375	134	809.3375	854.3375	174	810.3375	855.3375
15	806.3625	851.3625	55	807.3625	852.3625	95	808.3625	853.3625	135	809.3625	854.3625	175	810.3625	855.3625
16	806.3875	851.3875	56	807.3875	852.3875	96	808.3875	853.3875	136	809.3875	854.3875	176	810.3875	855.3875
17	806.4125	851.4125	57	807.4125	852.4125	97	808.4125	853.4125	137	809.4125	854.4125	177	810.4125	855.4125
18	806.4375	851.4375	58	807.4375	852.4375	98	808.4375	853.4375	138	809.4375	854.4375	178	810.4375	855.4375
19	806.4625	851.4625	59	807.4625	852.4625	99	808.4625	853.4625	139	809.4625	854.4625	179	810.4625	855.4625
20	806.4875	851.4875	60	807.4875	852.4875	100	808.4875	853.4875	140	809.4875	854.4875	180	810.4875	855.4875
21	806.5125	851.5125	61	807.5125	852.5125	101	808.5125	853.5125	141	809.5125	854.5125	181	810.5125	855.5125
22	806.5375	851.5375	62	807.5375	852.5375	102	808.5375	853.5375	142	809.5375	854.5375	182	810.5375	855.5375
23	806.5625	851.5625	63	807.5625	852.5625	103	808.5625	853.5625	143	809.5625	854.5625	183	810.5625	855.5625
24	806.5875	851.5875	64	807.5875	852.5875	104	808.5875	853.5875	144	809.5875	854.5875	184	810.5875	855.5875
25	806.6125	851.6125	65	807.6125	852.6125	105	808.6125	853.6125	145	809.6125	854.6125	185	810.6125	855.6125
26	806.6375	851.6375	66	807.6375	852.6375	106	808.6375	853.6375	146	809.6375	854.6375	186	810.6375	855.6375
27	806.6625	851.6625	67	807.6625	852.6625	107	808.6625	853.6625	147	809.6625	854.6625	187	810.6625	855.6625
28	806.6875	851.6875	68	807.6875	852.6875	108	808.6875	853.6875	148	809.6875	854.6875	188	810.6875	855.6875
29	806.7125	851.7125	69	807.7125	852.7125	109	808.7125	853.7125	149	809.7125	854.7125	189	810.7125	855.7125
30	806.7375	851.7375	70	807.7375	852.7375	110	808.7375	853.7375	150	809.7375	854.7375	190	810.7375	855.7375
31	806.7625	851.7625	71	807.7625	852.7625	111	808.7625	853.7625	151	809.7625	854.7625	191	810.7625	855.7625
32	806.7875	851.7875	72	807.7875	852.7875	112	808.7875	853.7875	152	809.7875	854.7875	192	810.7875	855.7875
33	806.8125	851.8125	73	807.8125	852.8125	113	808.8125	853.8125	153	809.8125	854.8125	193	810.8125	855.8125
34	806.8375	851.8375	74	807.8375	852.8375	114	808.8375	853.8375	154	809.8375	854.8375	194	810.8375	855.8375
35	806.8625	851.8625	75	807.8625	852.8625	115	808.8625	853.8625	155	809.8625	854.8625	195	810.8625	855.8625
36	806.8875	851.8875	76	807.8875	852.8875	116	808.8875	853.8875	156	809.8875	854.8875	196	810.8875	855.8875
37	806.9125	851.9125	77	807.9125	852.9125	117	808.9125	853.9125	157	809.9125	854.9125	197	810.9125	855.9125
38	806.9375	851.9375	78	807.9375	852.9375	118	808.9375	853.9375	158	809.9375	854.9375	198	810.9375	855.9375
39	806.9625	851.9625	79	807.9625	852.9625	119	808.9625	853.9625	159	809.9625	854.9625	199	810.9625	855.9625
40	806.9875	851.9875	80	807.9875	852.9875	120	808.9875	853.9875	160	809.9875	854.9875	200	810.9875	855.9875

APPENDIX C: 25 kHz Channel Spacing

TRUNKED RADIO SYSTEM FREQUENCY CHANNELLING PLAN (BLOCK B/B' 25 kHz)

CH. NO.	FREQ. (MHz)		CH. NO.	FREQ. (MHz)		CH. NO.	FREQ. (MHz)		CH. NO.	FREQ. (MHz)		CH. NO.	FREQ. (MHz)	
	Base Tx	Base Rx		Base Tx	Base Rx		Base Tx	Base Rx		Base Tx	Base Rx		Base Tx	Base Rx
201	811.0125	856.0125	241	812.0125	857.0125	281	813.0125	858.0125	321	814.0125	859.0125	361	815.0125	860.0125
202	811.0375	856.0375	242	812.0375	857.0375	282	813.0375	858.0375	322	814.0375	859.0375	362	815.0375	860.0375
203	811.0625	856.0625	243	812.0625	857.0625	283	813.0625	858.0625	323	814.0625	859.0625	363	815.0625	860.0625
204	811.0875	856.0875	244	812.0875	857.0875	284	813.0875	858.0875	324	814.0875	859.0875	364	815.0875	860.0875
205	811.1125	856.1125	245	812.1125	857.1125	285	813.1125	858.1125	325	814.1125	859.1125	365	815.1125	860.1125
206	811.1375	856.1375	246	812.1375	857.1375	286	813.1375	858.1375	326	814.1375	859.1375	366	815.1375	860.1375
207	811.1625	856.1625	247	812.1625	857.1625	287	813.1625	858.1625	327	814.1625	859.1625	367	815.1625	860.1625
208	811.1875	856.1875	248	812.1875	857.1875	288	813.1875	858.1875	328	814.1875	859.1875	368	815.1875	860.1875
209	811.2125	856.2125	249	812.2125	857.2125	289	813.2125	858.2125	329	814.2125	859.2125	369	815.2125	860.2125
210	811.2375	856.2375	250	812.2375	857.2375	290	813.2375	858.2375	330	814.2375	859.2375	370	815.2375	860.2375
211	811.2625	856.2625	251	812.2625	857.2625	291	813.2625	858.2625	331	814.2625	859.2625	371	815.2625	860.2625
212	811.2875	856.2875	252	812.2875	857.2875	292	813.2875	858.2875	332	814.2875	859.2875	372	815.2875	860.2875
213	811.3125	856.3125	253	812.3125	857.3125	293	813.3125	858.3125	333	814.3125	859.3125	373	815.3125	860.3125
214	811.3375	856.3375	254	812.3375	857.3375	294	813.3375	858.3375	334	814.3375	859.3375	374	815.3375	860.3375
215	811.3625	856.3625	255	812.3625	857.3625	295	813.3625	858.3625	335	814.3625	859.3625	375	815.3625	860.3625
216	811.3875	856.3875	256	812.3875	857.3875	296	813.3875	858.3875	336	814.3875	859.3875	376	815.3875	860.3875
217	811.4125	856.4125	257	812.4125	857.4125	297	813.4125	858.4125	337	814.4125	859.4125	377	815.4125	860.4125
218	811.4375	856.4375	258	812.4375	857.4375	298	813.4375	858.4375	338	814.4375	859.4375	378	815.4375	860.4375
219	811.4625	856.4625	259	812.4625	857.4625	299	813.4625	858.4625	339	814.4625	859.4625	379	815.4625	860.4625
220	811.4875	856.4875	260	812.4875	857.4875	300	813.4875	858.4875	340	814.4875	859.4875	380	815.4875	860.4875
221	811.5125	856.5125	261	812.5125	857.5125	301	813.5125	858.5125	341	814.5125	859.5125	381	815.5125	860.5125
222	811.5375	856.5375	262	812.5375	857.5375	302	813.5375	858.5375	342	814.5375	859.5375	382	815.5375	860.5375
223	811.5625	856.5625	263	812.5625	857.5625	303	813.5625	858.5625	343	814.5625	859.5625	383	815.5625	860.5625
224	811.5875	856.5875	264	812.5875	857.5875	304	813.5875	858.5875	344	814.5875	859.5875	384	815.5875	860.5875
225	811.6125	856.6125	265	812.6125	857.6125	305	813.6125	858.6125	345	814.6125	859.6125	385	815.6125	860.6125
226	811.6375	856.6375	266	812.6375	857.6375	306	813.6375	858.6375	346	814.6375	859.6375	386	815.6375	860.6375
227	811.6625	856.6625	267	812.6625	857.6625	307	813.6625	858.6625	347	814.6625	859.6625	387	815.6625	860.6625
228	811.6875	856.6875	268	812.6875	857.6875	308	813.6875	858.6875	348	814.6875	859.6875	388	815.6875	860.6875
229	811.7125	856.7125	269	812.7125	857.7125	309	813.7125	858.7125	349	814.7125	859.7125	389	815.7125	860.7125
230	811.7375	856.7375	270	812.7375	857.7375	310	813.7375	858.7375	350	814.7375	859.7375	390	815.7375	860.7375
231	811.7625	856.7625	271	812.7625	857.7625	311	813.7625	858.7625	351	814.7625	859.7625	391	815.7625	860.7625
232	811.7875	856.7875	272	812.7875	857.7875	312	813.7875	858.7875	352	814.7875	859.7875	392	815.7875	860.7875
233	811.8125	856.8125	273	812.8125	857.8125	313	813.8125	858.8125	353	814.8125	859.8125	393	815.8125	860.8125
234	811.8375	856.8375	274	812.8375	857.8375	314	813.8375	858.8375	354	814.8375	859.8375	394	815.8375	860.8375
235	811.8625	856.8625	275	812.8625	857.8625	315	813.8625	858.8625	355	814.8625	859.8625	395	815.8625	860.8625
236	811.8875	856.8875	276	812.8875	857.8875	316	813.8875	858.8875	356	814.8875	859.8875	396	815.8875	860.8875
237	811.9125	856.9125	277	812.9125	857.9125	317	813.9125	858.9125	357	814.9125	859.9125	397	815.9125	860.9125
238	811.9375	856.9375	278	812.9375	857.9375	318	813.9375	858.9375	358	814.9375	859.9375	398	815.9375	860.9375
239	811.9625	856.9625	279	812.9625	857.9625	319	813.9625	858.9625	359	814.9625	859.9625	399	815.9625	860.9625
240	811.9875	856.9875	280	812.9875	857.9875	320	813.9875	858.9875	360	814.9875	859.9875	400	815.9875	860.9875

APPENDIX D: 25 kHz Channel Spacing

TRUNKED RADIO SYSTEM FREQUENCY CHANNELLING PLAN (BLOCK C/C' 25 kHz)

CH. NO.	FREQ. (MHz)		CH. NO.	FREQ. (MHz)		CH. NO.	FREQ. (MHz)		CH. NO.	FREQ. (MHz)		CH. NO.	FREQ. (MHz)	
	Base Tx	Base Rx		Base Tx	Base Rx		Base Tx	Base Rx		Base Tx	Base Rx		Base Tx	Base Rx
401	816.0125	861.0125	441	817.0125	862.0125	481	818.0125	863.0125	521	819.0125	864.0125	561	820.0125	865.0125
402	816.0375	861.0375	442	817.0375	862.0375	482	818.0375	863.0375	522	819.0375	864.0375	562	820.0375	865.0375
403	816.0625	861.0625	443	817.0625	862.0625	483	818.0625	863.0625	523	819.0625	864.0625	563	820.0625	865.0625
404	816.0875	861.0875	444	817.0875	862.0875	484	818.0875	863.0875	524	819.0875	864.0875	564	820.0875	865.0875
405	816.1125	861.1125	445	817.1125	862.1125	485	818.1125	863.1125	525	819.1125	864.1125	565	820.1125	865.1125
406	816.1375	861.1375	446	817.1375	862.1375	486	818.1375	863.1375	526	819.1375	864.1375	566	820.1375	865.1375
407	816.1625	861.1625	447	817.1625	862.1625	487	818.1625	863.1625	527	819.1625	864.1625	567	820.1625	865.1625
408	816.1875	861.1875	448	817.1875	862.1875	488	818.1875	863.1875	528	819.1875	864.1875	568	820.1875	865.1875
409	816.2125	861.2125	449	817.2125	862.2125	489	818.2125	863.2125	529	819.2125	864.2125	569	820.2125	865.2125
410	816.2375	861.2375	450	817.2375	862.2375	490	818.2375	863.2375	530	819.2375	864.2375	570	820.2375	865.2375
411	816.2625	861.2625	451	817.2625	862.2625	491	818.2625	863.2625	531	819.2625	864.2625	571	820.2625	865.2625
412	816.2875	861.2875	452	817.2875	862.2875	492	818.2875	863.2875	532	819.2875	864.2875	572	820.2875	865.2875
413	816.3125	861.3125	453	817.3125	862.3125	493	818.3125	863.3125	533	819.3125	864.3125	573	820.3125	865.3125
414	816.3375	861.3375	454	817.3375	862.3375	494	818.3375	863.3375	534	819.3375	864.3375	574	820.3375	865.3375
415	816.3625	861.3625	455	817.3625	862.3625	495	818.3625	863.3625	535	819.3625	864.3625	575	820.3625	865.3625
416	816.3875	861.3875	456	817.3875	862.3875	496	818.3875	863.3875	536	819.3875	864.3875	576	820.3875	865.3875
417	816.4125	861.4125	457	817.4125	862.4125	497	818.4125	863.4125	537	819.4125	864.4125	577	820.4125	865.4125
418	816.4375	861.4375	458	817.4375	862.4375	498	818.4375	863.4375	538	819.4375	864.4375	578	820.4375	865.4375
419	816.4625	861.4625	459	817.4625	862.4625	499	818.4625	863.4625	539	819.4625	864.4625	579	820.4625	865.4625
420	816.4875	861.4875	460	817.4875	862.4875	500	818.4875	863.4875	540	819.4875	864.4875	580	820.4875	865.4875
421	816.5125	861.5125	461	817.5125	862.5125	501	818.5125	863.5125	541	819.5125	864.5125	581	820.5125	865.5125
422	816.5375	861.5375	462	817.5375	862.5375	502	818.5375	863.5375	542	819.5375	864.5375	582	820.5375	865.5375
423	816.5625	861.5625	463	817.5625	862.5625	503	818.5625	863.5625	543	819.5625	864.5625	583	820.5625	865.5625
424	816.5875	861.5875	464	817.5875	862.5875	504	818.5875	863.5875	544	819.5875	864.5875	584	820.5875	865.5875
425	816.6125	861.6125	465	817.6125	862.6125	505	818.6125	863.6125	545	819.6125	864.6125	585	820.6125	865.6125
426	816.6375	861.6375	466	817.6375	862.6375	506	818.6375	863.6375	546	819.6375	864.6375	586	820.6375	865.6375
427	816.6625	861.6625	467	817.6625	862.6625	507	818.6625	863.6625	547	819.6625	864.6625	587	820.6625	865.6625
428	816.6875	861.6875	468	817.6875	862.6875	508	818.6875	863.6875	548	819.6875	864.6875	588	820.6875	865.6875
429	816.7125	861.7125	469	817.7125	862.7125	509	818.7125	863.7125	549	819.7125	864.7125	589	820.7125	865.7125
430	816.7375	861.7375	470	817.7375	862.7375	510	818.7375	863.7375	550	819.7375	864.7375	590	820.7375	865.7375
431	816.7625	861.7625	471	817.7625	862.7625	511	818.7625	863.7625	551	819.7625	864.7625	591	820.7625	865.7625
432	816.7875	861.7875	472	817.7875	862.7875	512	818.7875	863.7875	552	819.7875	864.7875	592	820.7875	865.7875
433	816.8125	861.8125	473	817.8125	862.8125	513	818.8125	863.8125	553	819.8125	864.8125	593	820.8125	865.8125
434	816.8375	861.8375	474	817.8375	862.8375	514	818.8375	863.8375	554	819.8375	864.8375	594	820.8375	865.8375
435	816.8625	861.8625	475	817.8625	862.8625	515	818.8625	863.8625	555	819.8625	864.8625	595	820.8625	865.8625
436	816.8875	861.8875	476	817.8875	862.8875	516	818.8875	863.8875	556	819.8875	864.8875	596	820.8875	865.8875
437	816.9125	861.9125	477	817.9125	862.9125	517	818.9125	863.9125	557	819.9125	864.9125	597	820.9125	865.9125
438	816.9375	861.9375	478	817.9375	862.9375	518	818.9375	863.9375	558	819.9375	864.9375	598	820.9375	865.9375
439	816.9625	861.9625	479	817.9625	862.9625	519	818.9625	863.9625	559	819.9625	864.9625	599	820.9625	865.9625
440	816.9875	861.9875	480	817.9875	862.9875	520	818.9875	863.9875	560	819.9875	864.9875	600	820.9875	865.9875

APPENDIX E

TRUNKED RADIO SYSTEM CHANNEL ALLOTMENT PLAN (25 kHz Channel Spacing)

BLOCK		CHANNEL NO.										BLOCK		CHANNEL NO.									
MAIN	SUB	1	2	3	4	5	6	7	8	9	10	MAIN	SUB	401	402	403	404	405	406	407	408	409	410
A	A1	11	12	13	14	15	16	17	18	19	20	C	C1	411	412	413	414	415	416	417	418	419	420
		21	22	23	24	25	26	27	28	29	30			421	422	423	424	425	426	427	428	429	430
		31	32	33	34	35	36	37	38	39	40			431	432	433	434	435	436	437	438	439	440
		41	42	43	44	45	46	47	48	49	50			441	442	443	444	445	446	447	448	449	450
		51	52	53	54	55	56	57	58	59	60			451	452	453	454	455	456	457	458	459	460
A	A2	61	62	63	64	65	66	67	68	69	70	C	C2	461	462	463	464	465	466	467	468	469	470
		71	72	73	74	75	76	77	78	79	80			471	472	473	474	475	476	477	478	479	480
		81	82	83	84	85	86	87	88	89	90			481	482	483	484	485	486	487	488	489	490
		91	92	93	94	95	96	97	98	99	100			491	492	493	494	495	496	497	498	499	500
		101	102	103	104	105	106	107	108	109	110			501	502	503	504	505	506	507	508	509	510
A	A3	111	112	113	114	115	116	117	118	119	120	C	C3	511	512	513	514	515	516	517	518	519	520
		121	122	123	124	125	126	127	128	129	130			521	522	523	524	525	526	527	528	529	530
		131	132	133	134	135	136	137	138	139	140			531	532	533	534	535	536	537	538	539	540
		141	142	143	144	145	146	147	148	149	150			541	542	543	544	545	546	547	548	549	550
		151	152	153	154	155	156	157	158	159	160			551	552	553	554	555	556	557	558	559	560
A	A4	161	162	163	164	165	166	167	168	169	170	C	C4	561	562	563	564	565	566	567	568	569	570
		171	172	173	174	175	176	177	178	179	180			571	572	573	574	575	576	577	578	579	580
		181	182	183	184	185	186	187	188	189	190			581	582	583	584	585	586	587	588	589	590
		191	192	193	194	195	196	197	198	199	200			591	592	593	594	595	596	597	598	599	600
		201	202	203	204	205	206	207	208	209	210												
B	B1	211	212	213	214	215	216	217	218	219	220												
		221	222	223	224	225	226	227	228	229	230												
		231	232	233	234	235	236	237	238	239	240												
		241	242	243	244	245	246	247	248	249	250												
		251	252	253	254	255	256	257	258	259	260												
B	B2	261	262	263	264	265	266	267	268	269	270												
		271	272	273	274	275	276	277	278	279	280												
		281	282	283	284	285	286	287	288	289	290												
		281	282	283	284	285	286	287	288	289	290												
		291	292	293	294	295	296	297	298	299	300												

B	B2	301	302	303	304	305	306	307	308	309	310															
B	B3	311	312	313	314	315	316	317	318	319	320															
		321	322	323	324	325	326	327	328	329	330															
		331	332	333	334	335	336	337	338	339	340															
		341	342	343	344	345	346	347	348	349	350															
B	B4	351	352	353	354	355	356	357	358	359	360															
		361	362	363	364	365	366	367	368	369	370															
		371	372	373	374	375	376	377	378	379	380															
		381	382	383	384	385	386	387	388	389	390															
		391	392	393	394	395	396	397	398	399	400															

APPENDIX F
Summary of Spectrum Allocation for Mobile Radio Services

Service	TX-RX	Lower Frequency Limit (MHz)	Upper Frequency Limit (MHz)
DX +5 MHz (Leased Channel - Terminal)	TX	137.000	138.000
	RX	142.000	143.000
DX -5 MHz (Leased Channel - Subscriber)	TX	142.000	143.000
	RX	137.000	138.000
VHF Mobile Radio	TX	138.000	139.400
	RX	142.600	144.000
SX		138.025	141.975
Walkie-Talkie VHF (point-to-point)		141.000	142.000
SX		143.025	143.975
SX (Amateur)		144.000	145.975
DX +5 MHz (Leased Channel - Terminal)	TX	146.000	146.975
	RX	151.000	151.975
SX (amateur): 147.000 to 147.975		147.000	149.900
SX		150.050	150.975
DX - 5 MHz (Leased Channel - Subscriber)	TX	151.000	151.975
	RX	146.000	146.975
SX (Contains maritime mobile)	TX	152.000	162.975
DX + 10 MHz (Telemetry)	TX	163.000	163.125
	RX	173.000	173.125
DX +5 MHz (Leased Channel - Terminal) 163.225-163.850	TX	163.150	163.975
	RX	168.150	168.975
SX		164.000	164.975
DX +5 MHz (Police)	TX	165.000	167.975
	RX	170.000	172.975
SX		168.000	168.125
DX -5 MHz (Leased Channel - Subscriber) 168.225-168.850	TX	168.150	168.975
	RX	163.150	163.975
SX		169.000	169.975
DX -5 MHz	TX	170.000	172.975
	RX	165.000	167.975
DX -10 MHz (Telemetry)	TX	173.000	173.125
	RX	163.000	163.125
SX		173.150	174.000
Trunked Radio (Digital)	TX	380.000	389.975
	RX	390.000	400.000
DX +10 MHz	TX	404.000	404.975
	RX	414.000	414.975
DX +10 MHz (Telemetry 405.525-405.975)	TX	405.000	405.975
	RX	415.000	415.975
SX		406.125	406.950
DX +10 MHz (Trunking 407-408) / (Telemetry 406.975-416.975)	TX	406.975	407.975
	RX	416.975	417.975
SX		408	411.975
Service	TX-RX	Lower Frequency Limit	Upper Frequency Limit

		(MHz)	(MHz)
DX +10 MHz	TX	412.000	413.975
	RX	422.000	423.975
DX -10 MHz	TX	414.000	414.975
	RX	404.000	404.975
DX -10 MHz (Telemetry 415.525-415.975)	TX	415.000	415.975
	RX	405.000	405.975
DX -10 MHz (Trunking 417-418) / (Telemetry 416.975-406.975)	TX	416.975	417.975
	RX	406.975	407.975
SX		418.000	421.975
DX -10 MHz	TX	422	423.975
	RX	412.000	413.975
SX		424.000	425.975
SX		427.000	430.000
SX (Radiolocation)		430.000	434.975
DX +10 MHz	TX	435.000	439.975
	RX	445.000	449.975
DX +10 MHz	TX	440.000	440.600
	RX	450.000	450.600
SX		440.625	444.975
DX -10 MHz	TX	445.000	449.975
	RX	435.000	439.975
DX -10 MHz	TX	450.000	450.600
	RX	440.000	440.600
DX +10 MHz (Telemetry)	TX	450.625	450.725
	RX	460.625	460.725
SX		450.750	451.975
DX +10 MHz (ATUR-subscriber)	TX	452.000	456.275
	RX	462.000	466.275
SX (Walkie-talkie)		456.300	456.975
DX +10 MHz (Leased channel-terminal)	TX	457.000	457.975
	RX	467.000	467.975
DX +10 MHz (Police)	TX	458.000	458.975
	RX	468.000	468.975
DX +10 MHz	TX	459.000	459.975
	RX	469.000	469.975
SX		460.000	460.600
DX -10 MHz (Telemetry)	TX	460.625	460.725
	RX	450.625	450.725
SX		460.750	461.975
DX -10 MHz (ATUR-terminal)	TX	462.000	466.275
	RX	452.000	456.275
SX (Walkie-talkie)		466.300	466.975
DX -10 MHz (Leased Channel - subscriber)	TX	467.000	467.975
	RX	457.000	457.975
DX -10 MHz	TX	468.000	468.975
	RX	458.000	458.975
DX -10 MHz	TX	469.000	469.975
	RX	459.000	459.975

Service	TX-RX	Lower Frequency Limit (MHz)	Upper Frequency Limit (MHz)
UHF Mobile Radio	TX	443.013	443.988
	RX	448.013	448.988
Walkie-Talkie UHF (point-to-point)		456.525	456.975
		466.525	466.975
		477.000	477.250
Mobile Data	TX	478.000	484.000
	RX	488.000	494.000
Trunked Radio (Analogue)	TX	806.013	817.988
	RX	851.013	862.988

APENDIX G

List of Analogue TRS Service Providers and the numbers of AA held as at 31 July 2006

Client Name	Northern	Eastern	Central	Southern	Sabah	Sarawak	Grand Total
ACHI JAYA COMMUNICATIONS SDN BHD						44	44
CMRS TRUNK RADIO SDN. BHD.	17	6	49				72
COMETRON SDN.BHD.			25	43			68
ELECTCOMS SDN BHD	233	170	235	142	3	6	789
HASYON TEKNIK SDN. BHD.	15		40	5			60
MAL-TEL COMMUNICATION SDN BHD	10		39				49
PAGER COMMUNICATION SDN. BHD.		30					30
SAMEN TRUNK RADIO SDN. BHD.	5	8	34	30			77
SEGI MAJU SDN BHD	22	24	50	34			130
STARS ASSOCIATED SDN BHD		2	4		13	39	58
STR COMMUNICATION SDN BHD	10	10	5				25
SYARIKAT PELATUS SDN BHD	9	14	93				116
TEXTPHON (M) SDN. BHD.	31	13	17	14			75
WIDENET DISTRIBUTOR SDN BHD	55	30	10	35			130
Grand Total	407	307	601	303	16	89	1723

APPENDIX H

Conditions of AA

The issuance of the AA in the frequency bands in Blocks A and B shall be subject to the following conditions:

- (a) that the AA issued shall be cancelled upon the cancellation of the Network Facility Provider Individual Licence of the AA holder;
- (b) that the AA issued shall be suspended upon the suspension of the Network Facility Provider Individual Licence of the AA holder;
- (c) that AA holder shall comply with the Detailed Business Plan submitted to the Commission *in toto* unless modified with the approval of the Commission;
- (d) that there shall be no change in the shareholding of Network Facility Provider Individual Licence holder for a period of five years from the date of issuance of the first AA to the licensee; and
- (e) that Network Facility Provider Individual Licence holder shall submit a half yearly report to the Commission outlining the steps taken to implement the Detailed Business Plan as at **30 June** and **31 December** of each year.

APPENDIX I

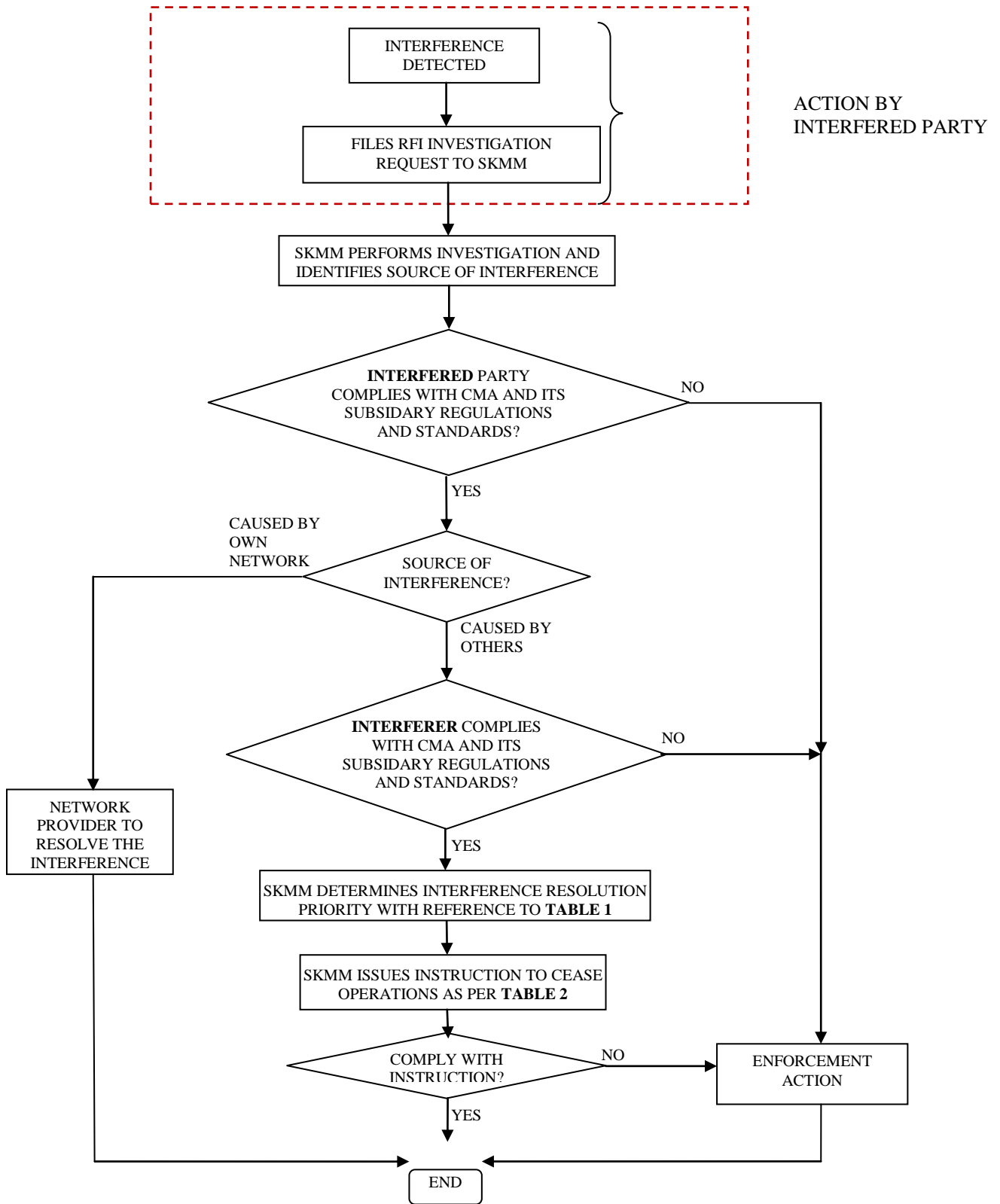

TABLE 1: INTERFERENCE RESOLUTION PRIORITY

	Resolution Type of Priority	Description
1	Service Priority	Primary has priority over secondary services. Among co- primary or co-secondary services, the stated priority is accorded as in the Spectrum Plan
2	Assignment Type Priority	Spectrum Assignment (SA) and Apparatus Assignment (AA) have equal priority but are of higher priority than Class Assignment (CA)
3	Service Type Priority	In the event where service priority and assignment type priority are equal for affected parties, the following list will determine the priority level for the interference case (the earlier in the list is given higher priority): <ul style="list-style-type: none"> i. Safety or Radionavigation service; ii. Based on the Date of Apparatus Assignment - Priority is given to the earliest/first installation

TABLE 2: INTERFERENCE RESOLUTION TIMELINE TO PARTIES

	Types of interference	Description	Resolution Timeline
1	Harmful	Interference which endangers or seriously degrades, obstructs or repeatedly interrupts the functioning of a radionavigation service or one or more safety services operating in accordance with CMA (Spectrum) Regulations 2000	To cease* operation immediately within 24 hours or earlier as specified in the notice issued by SKMM
2	Major	Electromagnetic interference rendering any apparatus or services unsuitable for their intended purpose. For this purpose interference to public correspondence service is considered under this category	To cease* operation within 3 days or earlier as specified in notice issued by SKMM if interference cannot be resolved.
3	Minor	Electromagnetic interference which does not affect the overall operation of any radiocommunications transmission.	To cease* operation within 7 days or earlier as specified in the notice issued by SKMM if interference cannot be resolved

*Note:

Resumption of operation of the apparatus is not allowed unless the assignment holder submit interference resolution or mitigation plan and complete implementation of the mitigation plan to the satisfaction of SKMM to remove/ avoid the interference.