



**MCMC SRSP FS 5.925  
10 OCTOBER 2017**

---

**Standard Radio System Plan**

**REQUIREMENTS FOR  
FIXED WIRELESS SYSTEMS  
OPERATING IN THE FREQUENCY BAND  
5925 MHz TO 6425 MHz**

---

Malaysian Communications and Multimedia Commission  
MCMC Tower 1, Jalan Impact, Cyber 6  
63000 Cyberjaya, Selangor Darul Ehsan, Malaysia  
Tel: +60 3 8688 8000 Fax: +60 3 8688 1005  
Website: <http://www.skmm.gov.my>

## TABLE OF CONTENTS

PAGE

1.0	FOREWORD.....	3
2.0	INTENT.....	4
3.0	GENERAL.....	4
4.0	CHANNEL ARRANGEMENT.....	5
5.0	REQUIREMENTS FOR USAGE OF SPECTRUM.....	7
6.0	PRINCIPLES OF ASSIGNMENT.....	9
7.0	IMPLEMENTATION.....	10
8.0	INTERNATIONAL COORDINATION REQUIREMENT.....	11
9.0	REVOCATION.....	11
10.0	REFERENCES.....	12

### APPENDICES

APPENDIX A:	SPECTRUM PLAN 5925 MHz TO 6425 MHz.....	13
APPENDIX B:	INTERFERENCE RESOLUTION PROCESS.....	15

**REQUIREMENTS FOR FIXED WIRELESS SYSTEMS  
OPERATING IN THE FREQUENCY BAND  
5925 MHz TO 6425 MHz**

**1.0 FOREWORD**

- 1.1 This Standard Radio System Plan (“SRSP”) is prepared by the Malaysian Communications and Multimedia Commission (“MCMC”) pursuant to the Communications and Multimedia Act 1998 (“Act”) and Spectrum Plan 2017 (“Spectrum Plan”) to provide information on minimum technical and regulatory requirements for efficient use of the frequency band **5925 MHz to 6425 MHz**.
- 1.2 This SRSP does not attempt to establish any detailed equipment standards.

## **2.0 INTENT**

- 2.1 This SRSP states the requirement for utilization of the frequency band of **5925 MHz to 6425 MHz** for digital transmission of Fixed Wireless Systems (“FWS”).
- 2.2 The intended use of these FWS is mainly for trunk/main link only. However, the use of FWS for mini/spur link may be considered on case-by-case basis.

## **3.0 GENERAL**

- 3.1 Although a wireless system conforms to the requirements of this SRSP, MCMC may require that modifications be made to the system whenever interference is caused or is likely to be caused to other radio stations or systems as listed in **Appendix A**.
- 3.2 All equipment installations must comply with the safety rules as specified in the applicable standards.
- 3.3 The equipment used shall be certified as required under regulation 14 of the Communications and Multimedia (Technical Standards) Regulations 2000.
- 3.4 The allocation and allotment of this frequency band and the information in this SRSP are subject to review by MCMC from time to time to reflect new developments in the communications and multimedia industry.

## 4.0 CHANNEL ARRANGEMENT

4.1 The radio frequency (“RF”) channel arrangement is based on the preferred RF channel arrangement in the International Telecommunication Union – Radiocommunication (“ITU-R”) **Recommendation F.383**. Users are encouraged to refer to the latest issue of the ITU-R document at the website link provided in paragraph 10.0 below.

4.2 For this SRSP, the preferred RF channel arrangement of up to eight (8) transmit and eight (8) receive channels with each channel accommodating a capacity of the order of 140 Mbit/s, or synchronous digital hierarchy bit-rates and operating in the lower **6 GHz** band, is derived as follows:

Let  $f_o$  be the centre frequency of the band of frequencies occupied (MHz),  
 $f_n$  be the centre frequency of one RF channel in the lower half of the band (MHz),  
 $f_{n'}$  be the centre frequency of one RF channel in the upper half of the band (MHz),

Note:

- i. The center frequency  $f_o$  is:  $f_o = 6175$  MHz
- ii. Separation between adjacent channels = 29.65 MHz
- iii. Separation between corresponding transmit and receive channels = 252.04 MHz

The frequencies of individual channels are expressed by the following relationship:

$$\text{lower half of the band: } f_n = f_o - 259.45 + 29.65 n \text{ MHz}$$

$$\text{upper half of the band: } f_{n'} = f_o - 7.41 + 29.65 n \text{ MHz}$$

where:  $n = 1, 2, 3, 4, 5, 6, 7$  or  $8$ .

The frequency arrangement is illustrated in **Figure 1** and the centre frequencies of RF channels are listed in **Table 1** below:

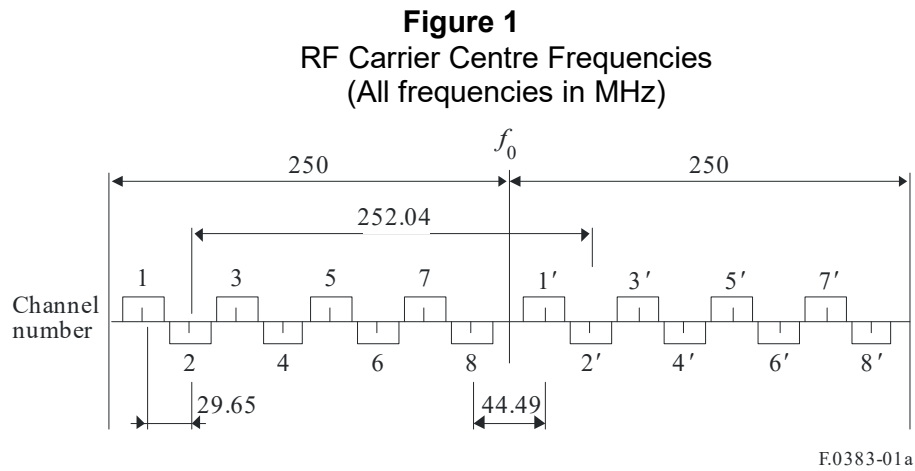

**Table 1**  
RF Carrier Centre Frequencies  
(bandwidth = 29.65 MHz)

Channel No.	Frequency (MHz)	Channel No.	Frequency (MHz)
1	5945.20	1'	6197.24
2	5974.85	2'	6226.89
3	6004.50	3'	6256.54
4	6034.15	4'	6286.19
5	6063.80	5'	6315.84
6	6093.45	6'	6345.49
7	6123.10	7'	6375.14
8	6152.75	8'	6404.79

## 5.0 REQUIREMENTS FOR USAGE OF SPECTRUM

- 5.1 This SRSP covers the minimum key characteristics considered necessary in order to make the best use of available frequencies.
- 5.2 The standard channel arrangement is as shown in **Table 1**. Usage of the transmit and receive channels shall comply with **Table 1**. All transmit channels should be in one half of the frequency band, and all receive channels should be in the other half of the frequency band.
- 5.3 The above channel arrangement primarily provides for eight (8) transmit and eight (8) receive radio frequency channels on the same route.
- 5.4 In a digital radio system, it is possible to accommodate the transmit and receive channels on a single antenna. The transmit and receive channels on a given section should then preferably use polarizations as shown in **Figure 1** above and **Table 2** below:

**Table 2**

Polarization	Transmit channel				Receive channel			
H(V)	1	3	5	7	1'	3'	5'	7'
V(H)	2	4	6	8	2'	4'	6'	8'

- 5.5 In the past deployment of analogue systems of up to 1800 channels, the following alternative arrangement of polarization, shown in **Figure 2** and **Table 3** below, has been used and may possibly be maintained in the initial migration to digital systems:

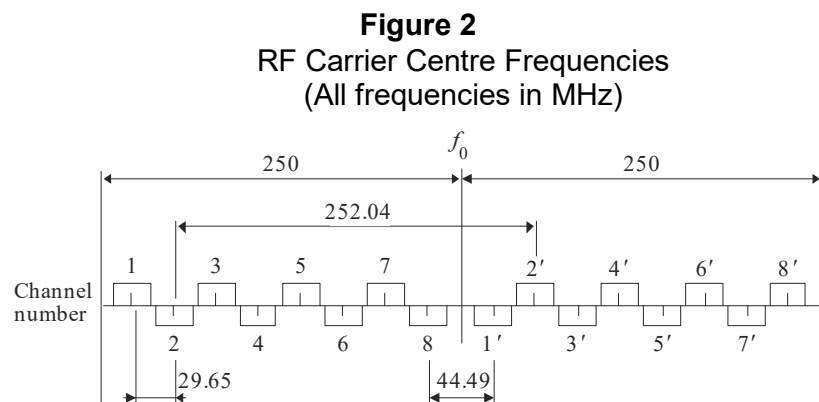

F.0383-1b

**Table 3**

<b>Polarization</b>	<b>Transmit channel</b>				<b>Receive channel</b>			
H(V)	1	3	5	7	2'	4'	6'	8'
V(H)	2	4	6	8	1'	3'	5'	7'

5.6 When the equipment and network characteristics permit, co-channel frequency reuse of the arrangement in **Figure 3** below can be employed for improving spectral efficiency:

**Figure 3**  
RF Co-channel Arrangement in high capacity FWS  
(All frequencies in MHz)

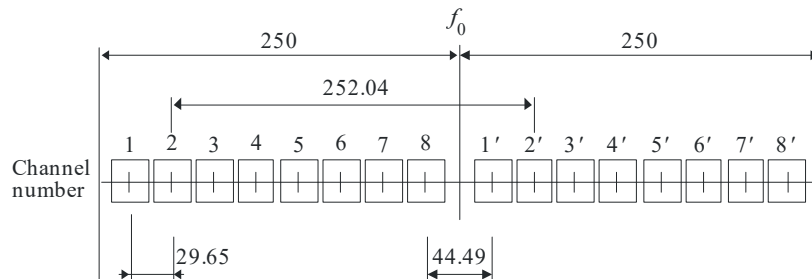

F0383-01c

- 5.7 When very high capacity links are required and network coordination permits, use of any two adjacent **29.65 MHz** channels is possible, for a wider bandwidth system, with centre frequency lying in the central point of the distance between the two **29.65 MHz** adjacent channels.
- 5.8 Protection channel may be permitted for multi-channel systems provided that it is duly approved by MCMC with the issuance of corresponding Apparatus Assignment (“AA”). However, systems using hot-standby are encouraged.
- 5.9 The frequencies assigned to a main route system shall be reused for spur routes and transmission routes (main and spur routes) and shall be planned to maximize frequency usage without any interference.
- 5.10 It should be noted that FWS in Fixed Service (“FS”) shares the frequency band 5925 MHz to 6425 MHz and is of the same primary status with Fixed-Satellite Service (“FSS”) and Mobile Service (“MS”) as shown in **Appendix A**. Currently this frequency band is used for FSS uplink for VSAT operation.



- 5.11 FWS in FS is to operate on non-interference basis (“NIB”) to the earth stations of FSS in the frequency band 5925 MHz to 6425 MHz, and shall comply with ITU-R **Recommendation SF.765** and **Article 21** of ITU Radio Regulations.
- 5.12 Special care must be taken by FWS providers during the network planning stage and installation of their equipment to avoid any interference to and from FSS earth stations. The FWS providers shall take full advantage of interference mitigation techniques such as antenna discrimination, tilt, polarization, frequency discrimination, shielding/blocking (introduce diffraction loss), site selection, and/or power control to facilitate the coordination of systems.
- 5.13 For the FWS providers’ own protection, receiving stations in FWS operating in the frequency band 5925 MHz to 6425 MHz should avoid directing their antennas towards the geostationary-satellite orbit and FSS earth stations. It is recommended to maintain a minimum separation angle as recommended in **Article 21** of the ITU Radio Regulations.
- 5.14 In the event that FWS causes interference to FSS Earth station, and the affected party files a report to MCMC for a resolution, MCMC will decide the necessary modifications and schedule of modifications to resolve the interference. MCMC will be guided by the interference resolution process as shown in **Appendix B**.

## **6.0 PRINCIPLES OF ASSIGNMENT**

- 6.1 Authorization to use FS spectrum for FWS station is by way of **Apparatus Assignment** (“AA”). Priority will be given to use of a station for trunk or main link.
- 6.2 AA shall be on first-come, first-serve basis.

- 6.3 Persons who are eligible to apply for an AA include:
- 6.3.1 Network Facilities Provider Individual [“NFP(I)”] license holder, which owns or provides radiocommunications transmitters and links; or
- 6.3.2 Private network facility (Government and private corporations or companies) for private use only.
- For use by private network facility other than offshore, an applicant has to provide proof that existing NFP(I) license holders are not able to provide FWS to the said applicant.
- 6.4 An application for an AA must be done in accordance with the Act and the relevant subsidiary legislations including the Communications and Multimedia (Spectrum) Regulations 2000 (“Spectrum Regulations”).
- 6.5 Technical analysis will be carried out by MCMC before an AA is issued. If necessary, operator-to-operator coordination at defined geographic boundaries may be required to mitigate interference.
- 6.6 An applicant is also encouraged to coordinate among existing stations prior to submission of the AA application.

## **7.0 IMPLEMENTATION**

- 7.1 This SRSP shall be effective on its date of issuance.
- 7.2 No AA for FWS operating in the frequency band 5925 MHz to 6425 MHz shall be approved unless its application complies with this SRSP and the requirements as set out in the Act and the relevant subsidiary legislations including the Spectrum Regulations.
- 7.3 AA is required from MCMC prior to the purchase and installation of any FWS equipment. Notwithstanding the above, any system installed or purchased prior to the effective date of this SRSP may be allowed to operate, subject to the issuance of AA by MCMC.

## **8.0 INTERNATIONAL BORDER COORDINATION REQUIREMENT**

8.1 Use of these frequency bands shall require coordination with Malaysia's neighbouring countries within the following coordination zones:

8.1.1 Within 30 kilometers of the Malaysian border with Singapore and Brunei Darussalam.

8.1.2 Within 30 kilometers of the Malaysian border with Indonesia.

8.1.3 Within 35 kilometers of the Malaysian border with Thailand.

8.2 It shall be noted that the above coordination distance is continuously being reviewed with Malaysia's neighbouring countries and may be updated from time to time.

8.3 Issuance of an AA is subject to the successful co-ordination among assigned stations and with the neighbouring countries where it applies.

8.4 The technical mitigation guide as mentioned in paragraph 5.0 above shall be applied if operator-to-operator coordination is required.

8.5 In the event of any interference, MCMC will require the affected users to carry out an operator-to-operator coordination. In the event that the interference remains unresolved after 24 hours by the operators, the affected parties may escalate the matter to MCMC for a resolution. MCMC will decide the necessary modifications and schedule of modifications to resolve the interference. MCMC will be guided by the interference resolution process as shown in **Appendix B**.

## **9.0 REVOCATION**

9.1 SKMM SRSP – 512 FS Issue 3 dated 15 October 2009 is hereby revoked.

## 10.0 REFERENCES

- [1] **ITU-R F.383** Radio-Frequency channel arrangements for high-capacity fixed wireless systems operating in the lower 6 GHz (5 925 to 6 425 MHz) band.
  - Link to document: [www.itu.int/rec/R-REC-F.383/en](http://www.itu.int/rec/R-REC-F.383/en)
  
- [2] **ITU-R SF.765** Intersection of radio-relay antenna beams with orbits used by space stations in the fixed-satellite service.
  - Link to document: [www.itu.int/rec/R-REC-SF.765/en](http://www.itu.int/rec/R-REC-SF.765/en)
  
- [3] **ITU Radio Regulations Article 21** Terrestrial and Space Services Sharing Frequency Bands above 1 GHz.
  
- [4] **Spectrum Plan**
  - Link to document: <http://www.skmm.gov.my/Spectrum/Spectrum-Management.aspx>

**Issued by:**



**Malaysian Communications and Multimedia  
Commission**

**10 October 2017**

## APPENDIX A: SPECTRUM PLAN

Frequency Band (MHz)	ITU Allocation			Malaysian Allocation
	Region 1	Region 2	Region 3	
5 925-6 700	FIXED 5.547 FIXED-SATELLITE (Earth-to-space) 5.457A 5.457B MOBILE 5.457C  5.149 5.440 5.458			FIXED 5.457 MLA61 MLA62  FIXED-SATELLITE (Earth-to-space) 5.457A  MOBILE  5.149 5.440 5.458 MLA3 MLA58A MLA102

5.149 In making assignments to stations of other services to which the bands:

13 360-13 410 kHz,	4 950-4 990 MHz,	102-109.5 GHz,
25 550-25 670 kHz,	4 990-5 000 MHz,	111.8-114.25 GHz,
37.5-38.25 MHz,	6 650-6 675.2 MHz,	128.33-128.59 GHz,
73-74.6 MHz in Regions 1 and 3,	10.6-10.68 GHz,	129.23-129.49 GHz,
150.05-153 MHz in Region 1,	14.47-14.5 GHz,	130-134 GHz,
322-328.6 MHz,	22.01-22.21 GHz,	136-148.5 GHz,
406.1-410 MHz,	22.21-22.5 GHz,	151.5-158.5 GHz,
608-614 MHz in Regions 1 and 3,	22.81-22.86 GHz,	168.59-168.93 GHz,
1 330-1 400 MHz,	23.07-23.12 GHz,	171.11-171.45 GHz,
1 610.6-1 613.8 MHz,	31.2-31.3 GHz,	172.31-172.65 GHz,
1 660-1 670 MHz,	31.5-31.8 GHz in Regions 1 and 3,	173.52-173.85 GHz,
1 718.8-1 722.2 MHz,	36.43-36.5 GHz,	195.75-196.15 GHz,
2 655-2 690 MHz,	42.5-43.5 GHz,	209-226 GHz,
3 260-3 267 MHz,	48.94-49.04 GHz,	241-250 GHz,
3 332-3 339 MHz,	76-86 GHz,	252-275 GHz,
3 345.8-3 352.5 MHz,	92-94 GHz,	
4 825-4 835 MHz,	94.1-100 GHz	

are allocated, administrations are urged to take all practicable steps to protect the radio astronomy service from harmful interference. Emissions from spaceborne or airborne stations can be particularly serious sources of interference to the radio astronomy service (see Nos. 4.5 and 4.6 and Article 29). (WRC-07)

5.440 The standard frequency and time signal-satellite service may be authorized to use the frequency 4 202 MHz for space-to-Earth transmissions and the frequency 6 427 MHz for Earth-to-space transmissions. Such transmissions shall be confined within the limits of  $\pm 2$  MHz of these frequencies, subject to agreement obtained under No. 9.21.

- 5.457 In Australia, Burkina Faso, Cote d'Ivoire, Mali and Nigeria, the allocation to the fixed service in the bands 6 440-6 520 MHz (HAPS-to-ground direction) and 6 560-6 640 MHz (ground-to-HAPS direction) may also be used by gateway links for high-altitude platform stations (HAPS) within the territory of these countries. Such use is limited to operation in HAPS gateway links and shall not cause harmful interference to, and shall not claim protection from, existing services, and shall be in compliance with Resolution 150 (WRC-12). Existing services shall not be constrained in future development by HAPS gateway links. The use of HAPS gateway links in these bands requires explicit agreement with other administrations whose territories are located within 1 000 kilometres from the border of an administration intending to use the HAPS gateway links. (WRC-12)
- 5.457A In the frequency bands 5 925-6 425 MHz and 14-14.5 GHz, earth stations located on board vessels may communicate with space stations of the fixed-satellite service. Such use shall be in accordance with Resolution 902 (WRC-03). In the frequency band 5 925-6 425 MHz, earth stations located on board vessels and communicating with space stations of the fixed-satellite service may employ transmit antennas with minimum diameter of 1.2 m and operate without prior agreement of any administration if located at least 330 km away from the low-water mark as officially recognized by the coastal State. All other provisions of Resolution 902 (WRC-03) shall apply. (WRC-15)
- 5.457B In the frequency bands 5 925-6 425 MHz and 14-14.5 GHz, earth stations located on board vessels may operate with the characteristics and under conditions contained in Resolution 902 (WRC-03) in Algeria, Saudi Arabia, Bahrain, Comoros, Djibouti, Egypt, United Arab Emirates, Jordan, Kuwait, Libya, Morocco, Mauritania, Oman, Qatar, the Syrian Arab Republic, Sudan, Tunisia and Yemen, in the maritime mobile-satellite service on a secondary basis. Such use shall be in accordance with Resolution 902 (WRC-03). (WRC-15)
- 5.457C In Region 2 (except Brazil, Cuba, French overseas departments and communities, Guatemala, Mexico, Paraguay, Uruguay and Venezuela), the frequency band 5 925-6 700 MHz may be used for aeronautical mobile telemetry for flight testing by aircraft stations (see No. 1.83). Such use shall be in accordance with Resolution 416 (WRC-07) and shall not cause harmful interference to, or claim protection from, the fixed-satellite and fixed services. Any such use does not preclude the use of these frequency bands by other mobile service applications or by other services to which these frequency bands are allocated on a co-primary basis and does not establish priority in the Radio Regulations. (WRC-15)
- 5.458 In the band 6 425-7 075 MHz, passive microwave sensor measurements are carried out over the oceans. In the band 7 075-7 250 MHz, passive microwave sensor measurements are carried out. Administrations should bear in mind the needs of the Earth explorations-satellite (passive) and space research (passive) services in their future planning of the bands 6 425-7 025 MHz and 7 075-7 250 MHz.

MLA3 Class Assignment

MLA58A Priority to satellite network filed under the administration of Malaysia at 91.5° East orbital slot in the Fixed Satellite Service. Fixed Service stations may operate on a non-interference basis.

MLA61 Standard Radio System Plan 512: Requirements for Fixed Service Line-Of-Sight Radio-Relay Systems Operating in the Frequency Band from 5925 MHz to 6425 MHz.

MLA62 Standard Radio System Plan 513: Requirements for Fixed Service Line-Of-Sight Radio-Relay Systems Operating in the Frequency Band from 6430 MHz to 7110 MHz.

MLA102 Standard Radio System Plan 549: Requirements for Devices using Ultra-Wideband (UWB) Technology Operating in the Frequency Bands from 30 MHz to 960 MHz, 2.17 GHz to 10.6 GHz, 21.65 GHz to 29.5 GHz and 77 GHz to 81 GHz.

*Note: The texts above will be updated with the following texts during the next review exercise of the Spectrum Plan document:*

*MLA61 Standard Radio System Plan FS 5.925: Requirements for Fixed Wireless Systems Operating in the Frequency Band 5 925 MHz to 6 425 MHz.*

*MLA62 Standard Radio System Plan FS 6.425: Requirements for Fixed Wireless Systems Operating in the Frequency Band 6 425 MHz to 7 110 MHz.*

## APPENDIX B: INTERFERENCE RESOLUTION PROCESS

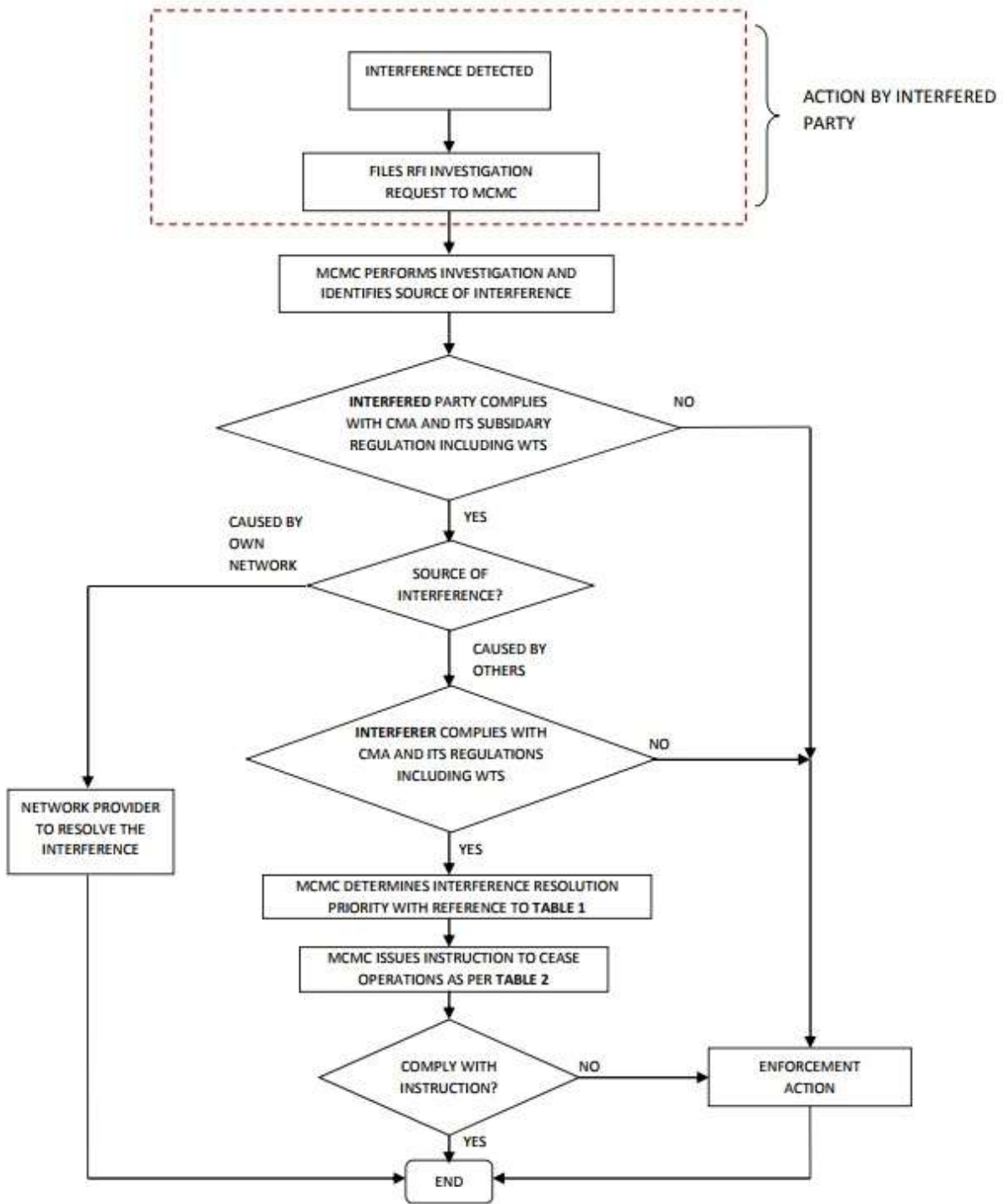

**TABLE 1: INTERFERENCE RESOLUTION PRIORITY**

	Resolution Type of Priority	Description
1	Service Priority	Primary services has priority over secondary services. Among co-primary or co-secondary services, the stated priority is accorded as provided in the Spectrum Plan.
2	Assignment Type Priority	Spectrum Assignment (SA) and Apparatus Assignment (AA) have equal priority but are of higher priority than Class Assignment (CA).
3	Service Type Priority	In the event where service priority and assignment type priority are equal for affected parties, the following list will determine the priority level for the interference case (the earlier in the list is given higher priority): <ul style="list-style-type: none"> <li>i. Safety or Radionavigation service.</li> <li>ii. Based on the Date of Apparatus Assignment - Priority is given to the earliest/first installation.</li> </ul>

**TABLE 2: INTERFERENCE RESOLUTION TIMELINE TO PARTIES**

	Types of interference	Description	Resolution Timeline
1	Harmful	Interference which endangers or seriously degrades, obstructs or repeatedly interrupts the functioning of a radionavigation service or one or more safety services operating in accordance with the Communications and Multimedia (Spectrum) Regulations 2000	To cease* operation immediately within 24 hours or earlier as specified in the notice issued by MCMC.
2	Major	Electromagnetic interference rendering any apparatus or services unsuitable for their intended purpose.  For this purpose, interference to public correspondence service is considered under this category.	To cease* operation within 3 days or earlier as specified in notice issued by MCMC if interference cannot be resolved.
3	Minor	Electromagnetic interference which does not affect the overall operation of any radiocommunications transmission.	To cease* operation within 7 days or earlier as specified in the notice issued by MCMC if interference cannot be resolved.

\*Note:

Resumption of operation of the apparatus is not allowed unless the assignment holder submits an interference resolution or a mitigation plan and has completed the implementation of the interference resolution and/or mitigation plan to the satisfaction of MCMC to remove/avoid the interference.