

# TECHNICAL CODE

## BASIC CIVIL WORKS - PART 5: LAST MILE FIXED NETWORK TELECOMMUNICATIONS POLE

Developed by



Registered by



Registered date: 20 November 2025

© Copyright 2025

## **MCMC MTSFB TC G025-5:2025**

### **Development of technical codes**

The Communications and Multimedia Act 1998 (Laws of Malaysia Act 588) ('the Act') provides for a Technical Standards Forum designated under Section 184 of the Act or the Malaysian Communications and Multimedia Commission ('the Commission') to prepare a technical code. The technical code prepared pursuant to Section 185 of the Act shall consist of, at least, the requirements for network interoperability and the promotion of safety of network facilities.

Section 96 of the Act also provides for the Commission to determine a technical code in accordance with Section 55 of the Act if the technical code is not developed under an applicable provision of the Act and it is unlikely to be developed by the Technical Standards Forum within a reasonable time.

In exercise of the power conferred by Section 184 of the Act, the Commission has designated the Malaysian Technical Standards Forum Bhd ('MTSFB') as a Technical Standards Forum which is obligated, among others, to prepare the technical code under Section 185 of the Act.

A technical code prepared in accordance with Section 185 shall not be effective until it is registered by the Commission pursuant to Section 95 of the Act.

For further information on the technical code, please contact:

#### **Malaysian Communications and Multimedia Commission (MCMC)**

MCMC Tower 1  
Jalan Impact  
Cyber 6  
63000 Cyberjaya  
Selangor Darul Ehsan  
MALAYSIA

Tel : +60 3 8688 8000  
Fax : +60 3 8688 1000  
Email : [stpd@mcmc.gov.my](mailto:stpd@mcmc.gov.my)  
Website: [www.mcmc.gov.my](http://www.mcmc.gov.my)

OR

#### **Malaysian Technical Standards Forum Bhd (MTSFB)**

Level 3A, MCMC Tower 2  
Jalan Impact  
Cyber 6  
63000 Cyberjaya  
Selangor Darul Ehsan  
MALAYSIA

Tel : +60 3 8680 9950  
Fax : +60 3 8680 9940  
Email : [support@mtsfb.org.my](mailto:support@mtsfb.org.my)  
Website: [www.mtsfb.org.my](http://www.mtsfb.org.my)

**Contents**

	<b>Page</b>
Committee representation.....	iii
Foreword .....	iv
0. Introduction.....	1
1. Scope .....	1
2. Normative references .....	1
3. Abbreviations.....	2
4. Terms and definitions.....	2
5. Planning for last mile pole .....	5
5.1 Infrastructure demarcation.....	6
5.1.1 Phase 1: Development.....	6
5.1.2 Phase 2: Post-development.....	7
5.2 Pole distribution design.....	8
5.3 Premises access pole.....	9
5.4 Planning in greenfield and brownfield infrastructure area .....	9
5.4.1 Planning in greenfield infrastructure area .....	9
5.4.2 Planning in brownfield infrastructure area.....	10
6. Infrastructure requirements .....	11
6.1 Pole specification.....	11
6.1.1 Basic design wind speed.....	11
6.1.2 Design Load .....	11
6.2 Pole installation.....	12
6.3 Stay wire and strut .....	13
6.4 Pole marking.....	13
6.5 Accessibility .....	14
7. Cabling requirements .....	14
7.1 Cables positioning .....	14
7.2 Splice closure positioning .....	15
7.3 Optimal distances between cables .....	16
7.4 Cable organisation and maintenance .....	16
7.5 Distribution Points (DP) .....	16
7.6 Cable sag.....	16
7.7 Distance between power and telecommunication cables.....	17
8. Installation works for Fibre Distribution Cabinets (FDC).....	17
8.1 General requirement.....	17
8.1.1 Temporary Occupation License (TOL) application .....	17

## **MCMC MTSFB TC G025-5:2025**

8.1.2	Approval for Fibre Distribution Cabinets (FDC)s construction on local authority road reserve .....	18
8.2	Fibre Distribution Cabinet (FDC) requirement .....	18
9.	Excavation works.....	18
10.	Infrastructure and cabling acceptance procedure .....	19
11.	Safety and precaution .....	19
Annex A	Abbreviations .....	20
Annex B	Calculation for the number of cables on poles .....	21
Bibliography	.....	26

## **Committee representation**

This technical code was developed by the Fixed Network Facilities Working Group of the Malaysian Technical Standards Forum Bhd (MTSFB), which consists of representatives from the following organisations:

Asaascom Engineering Sdn Bhd  
CelcomDigi Berhad  
Malaysia Digital Economy Corporation Sdn Bhd  
Maxis Broadband Sdn Bhd  
PMW Concrete Industries Sdn Bhd  
Redsun Engineering Sdn Bhd  
SIRIM Berhad  
Terengganu Telecommunications Sdn Bhd  
TM Technology Services Sdn Bhd  
TT Dotcom Sdn Bhd  
U Mobile Sdn Bhd  
Universiti Teknikal Malaysia Melaka  
Universiti Teknologi Malaysia

# **MCMC MTSFB TC G025-5:2025**

## **Foreword**

This technical code for the Basic Civil Works - Last Mile Fixed Network Telecommunications Pole ('Technical Code') was developed pursuant to the Act by the Fixed Network Facilities Working Group of the Malaysian Technical Standards Forum Bhd (MTSFB).

MCMC MTSFB TC G025-5:2025, Last Mile Fixed Network Telecommunications Poles consists of the following parts, under the general title *Basic Civil Works*:

*Part 1: General Requirements*

*Part 2: Open Trench*

*Part 3: Micro Trench*

*Part 4: Horizontal Directional Drilling*

*Part 5: Last Mile Fixed Network Telecommunications Pole*

This Technical Code (Part 5: Last Mile Fixed Network Telecommunications Pole) consists of requirements for fixed network telecommunications poles for the last mile connectivity. This Technical Code shall be read together with the rest of the series of *Basic Civil Works*, depending on the specific method of civil work.

This Technical Code shall serve as a replacement for any fixed network telecommunication pole requirements mentioned in any other Technical Code. It supersedes the specific requirements mentioned therein.

This Technical Code shall continue to be valid and effective from the date of its registration until it is replaced or revoked.

## BASIC CIVIL WORKS - PART 5: LAST MILE FIXED NETWORK TELECOMMUNICATIONS POLE

### 0. Introduction

Deploying fixed network telecommunication presents several challenges. The high costs associated with building and maintaining the infrastructure are significant, especially since the last mile involves connecting the main network to the last mile connectivity, such as individual homes and commercial areas. Geographical barriers, such as remote locations and difficult terrain, further complicate and increase the cost of installation. Additionally, handling local regulations and obtaining the necessary permits can be time-consuming and may incur fees set by the authorities. Existing infrastructure limitations may also require upgrades or replacements, adding to the complexity.

Allowing multiple operators to share the same pole reduces the overall infrastructure costs, as expenses are divided among providers. This cost-sharing approach not only lessens the financial burden on each operator but also speeds up deployment. Providers can avoid duplicating efforts, resulting in a more streamlined and efficient installation.

This Technical Code is intended as a reference for architects, engineers, property owners, developers, service providers, and other stakeholders involved in the planning and installation of fixed network telecommunications poles. It provides a comprehensive guide on the construction of these critical infrastructure elements, prioritising structural integrity, longevity, and innovative approaches to shared pole utilisation among Network Service Providers (NSPs), thereby promoting efficient and collaborative infrastructure development.

### 1. Scope

This Technical Code specifies the requirements for infrastructure sharing for fixed network telecommunications poles in last-mile areas, which cover the following items:

- a) planning and site selection;
- b) pole design and specifications;
- c) construction and installation; and
- d) safety, maintenance, and repair.

### 2. Normative references

The following normative references are indispensable for the application of this Technical Code. For dated references, only the edition cited applies. For undated references, the latest edition of the normative references (including any amendments) applies.

*Electricity Supply Act 1990 (Act 447)*

*Strata Management Act 2013 (Act 757)*

*Strata Titles Act 1985 (Act 318)*

*Commission Determination on the Mandatory Standard on Access, Determination No. 1 of 2022, or its subsequent Determinations*

## **MCMC MTSFB TC G025-5:2025**

MCMC MTSFB TC G024, *Fixed Network Facilities - In-Building and External*

MCMC MTSFB TC G025, *Basic Civil Works*

JIS A5373, *Precast Prestressed Concrete Products*

ASCE 7, *Minimum Design Loads and Associated Criteria for Buildings and Other Structures*

### **3. Abbreviations**

For the purposes of this Technical Code, the following abbreviations apply.

See Annex A.

### **4. Terms and definitions**

For the purposes of this Technical Code, the following definitions apply.

#### **4.1 Access seeker**

Access seeker means a network facilities provider, a network service provider, an applications service provider, or a content applications service provider who is a licensee as defined in the Act and who makes a written request for access to facilities and/or services listed in the Commission Determination on Access List, Determination No. 6 of 2021, or its subsequent Determinations.

#### **4.2 Broadband**

High-speed internet access where data, e-mail, videos, music, and other applications can be downloaded at speeds significantly faster than those available through dial-up modems.

#### **4.3 Brownfield infrastructure area**

An area where existing fixed network infrastructure is already available.

#### **4.4 Concrete kicking block**

A pole accessory to prevent the pole from slanting in sandy or soft soil environments, and it is designed for outdoor use in areas with high humidity and heavy rainfall. The kicking block is designed to tie to the pole by using a U-bolt and nuts.

#### **4.5 Distribution Side (D-Side) network**

The Distribution Side (D-Side) network refers to the infrastructure and components that distribute fibre optic services from the Fibre Distribution Cabinet (FDC) to individual customer premises. This segment is responsible for bringing high-speed internet, voice, and video services to homes and businesses. The D-Side network may include any of the following components.

- a) Fibre-to-the-Curb (FTTC) or Fibre-to-the-Home (FTTH) connections;
- b) FDC that serves as a central point for distributing fibre optic cables to individual customers;
- c) Fibre optic cables and splices that connect the FDC to customer premises; and

- d) Optical Network Terminals (ONT) that convert the fibre optic signal to a format compatible with customer devices.

**4.6 Exchange Side (E-Side) network, including trunk or junction network**

The Exchange Side (E-Side) network, also known as the backbone or backhaul network, handles the distribution of fibre optic cables from the service provider's central office or exchange to various FDCs in the network. This segment is responsible for connecting multiple distribution hubs and providing high-capacity connectivity between them. The E-Side network may include any of the following components:

- a) high-capacity fibre optic cables and trunking systems;
- b) fibre optic repeaters or amplifiers that boost signal strength and extend transmission distances;
- c) junction points or nodes that connect multiple fibre optic cables and enable signal routing; and
- d) central offices or exchanges that serve as hubs for connecting multiple fibre optic cables and providing access to the wider telecommunications network.

Figure 1 illustrates the example of the E-Side and D-Side of a fixed network architecture.

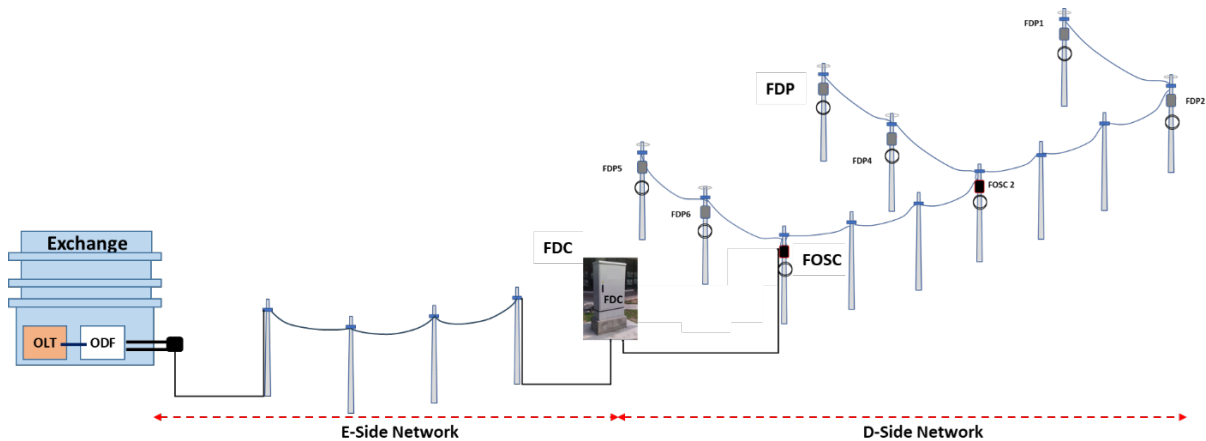

**Figure 1. Example of E-Side and D-Side network**

**4.7 Fibre optic cable**

High-speed data transmission medium. Fibre is a future-proof technology that has the ability to accommodate any new technologies and applications that require higher bandwidth.

**4.8 Fibre-To-The Premises (FTTP)**

Generic term for providing fixed network services via fibre optic cable from NFP Central Office (CO), direct to end user premises. Fibre-To-The Premises (FTTP) is an enhancement of legacy technologies, such as using a metal cable network via Public Switched Telephone Network (PSTN) or Digital Subscriber Line (DSL) technology.

**4.9 Fixed network telecommunications pole**

An infrastructure element that serves as a support structure for telecommunication cables and equipment. Its primary function is to facilitate the deployment of telecommunication networks, ensuring reliable and efficient communication services. It is also known as a telecommunication aerial pole.

## **MCMC MTSFB TC G025-5:2025**

### **4.10 Greenfield infrastructure area**

A new or existing development area with no fixed-line infrastructure available.

### **4.11 Housing scheme**

Group of houses and other buildings built together as a single development. A housing scheme is usually built by a developer and may consist of residential and/or commercial, Single Dwelling Unit (SDU) and Multi-Dwelling Unit (MDU) type of properties.

### **4.12 Landed strata development**

A strata title is a form of ownership, usually meant for MDU, and horizontal subdivisions with shared areas and facilities. A strata scheme is thus defined as a property development that divides buildings or land into parcels and common property under a management system.

A landed strata property is basically a landed house or SDU, but with MDU-style facilities such as a swimming pool and gym. These developments may consist of bungalows, semi-detached or terrace houses, ranging from single storey to 3-storeys in height.

The strata rules only apply to infrastructure, except for individual parcels, inclusive of the external and internal telecommunication infrastructure outside of the individual units.

Landed strata property with strata titles falls under the protection and governance of the Strata Management Act 2013 (Act 757) and the Strata Titles Act 1985 (Act 318).

### **4.13 Last mile**

The final network connection to the customers. It is a network link between NSP's central office and the customer's premises.

### **4.14 Management Corporation (MC)**

The Management Corporation (MC), which has come into existence upon the opening of a book of the strata register in respect of subdivided building or land under sub-Section 17(3) of the Strata Titles Act 1985, is a corporate body having perpetual succession and a common seal. The MC consists of all the strata unit owners.

### **4.15 Network Facilities Provider (NFP)**

An entity that is registered with the Commission to own or provide a network facility in accordance with the Communication and Multimedia Act 1998 (Act 588) and its Regulations.

### **4.16 Network Services Provider (NSP)**

An entity that is registered with the Commission to provide a network service in accordance with the Communication and Multimedia Act 1998 (Act 588) and its Regulations.

### **4.17 Parcel owner**

The purchaser or the developer in respect of those parcels in the strata development area which have not been sold by the developer.

#### **4.18 Pole sharing**

An infrastructure where multiple telecommunications service providers utilise the same physical poles or structures to deploy their network equipment. This collaborative approach facilitates the installation and maintenance of telecommunication services while minimising costs and environmental impacts.

#### **4.19 Private Property Line (PPL)**

A legal property development boundary as specified in the land title. This boundary shall determine the separation between public or other personal and private areas.

#### **4.20 Property developer**

In relation to a development area, means any person or body of persons, by whatever name described, who develops any land for the purpose of residential, commercial, or industrial use, or a combination of such uses.

In relation to a subdivided building or land, includes the original proprietor of the lot before the subdivision and includes the executors, administrators and successors-in-title and permitted assigns of such person or body of persons, and in a case where the person or body of persons is under liquidation, includes such person or body appointed by a court of competent jurisdiction to be the provisional liquidator or liquidator.

#### **4.21 Property owner**

Any person or body for the time being registered as the proprietor of any alienated land.

For a strata scheme, the property owner is defined as specified in the Strata Management Act 2013 (Act 757) and the Strata Titles Act 1985 (Act 318).

The property owner is responsible for maintaining the infrastructure provided within the Private Property Line (PPL) is in good condition. It may include the developer, an individual owner, a Joint Management Body (JMB), MC, Subsidiary Management Corporation (Sub-MC), or parcel owner.

#### **4.22 Subsidiary Management Corporation (Sub-MC)**

A Sub-MC is in relation to limited common property created under Section 17A, Strata Titles Act 1985 (Act 318).

#### **4.23 Single Dwelling Unit (SDU)**

A landed property or building with less than 6 storeys, which is generally not equipped with a Telecommunication Room (TR). Examples of SDU are as follows:

- a) terrace houses.
- b) bungalows; and
- c) shop houses.

### **5. Planning for last mile pole**

Planning for the last mile pole is vital for ensuring service reliability, optimising resource use, ensuring user accessibility and responsibility. It also ensures compliance with regulations, addressing safety and minimising environmental impact, which ensures that future infrastructure needs are met while minimising the need for duplicate construction and reducing environmental impact.

# MCMC MTSFB TC G025-5:2025

## 5.1 Infrastructure demarcation

The PPL serves as the boundary demarcation point for infrastructure between the developer, property owner, and Network Facilities Provider (NFP). The developer is responsible for providing the infrastructure within the PPL. Once provided, ownership and responsibility for this infrastructure will be transferred to the property owner.

The demarcation and responsibilities of the developer, property owner, and NFP can be divided into the following two phases:

- a) Phase 1: Development; and
- b) Phase 2: Post development.

### 5.1.1 Phase 1: Development

The developer is required to provide a dedicated space or location for NSP to place the cabinet within the PPL for the SDU during the development phase, as illustrated in Figure 2. It is the developer's responsibility to ensure that all necessary infrastructure and facilities needed to support fixed network services are provided.

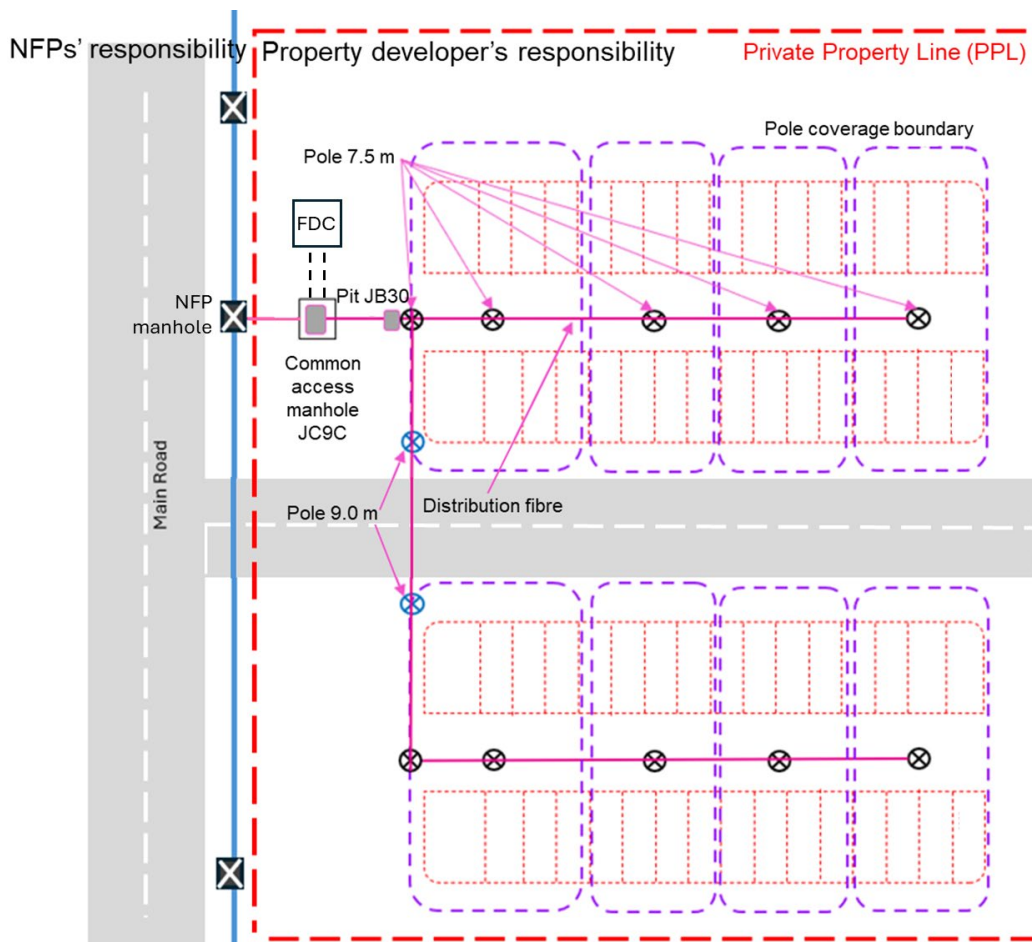

**Figure 2. SDU infrastructure demarcation point**

Upon completion of the development phase, the ownership of the infrastructure within the PPL shall be transferred to the JMB, MC, or any relevant parties with a formal handover agreement. Details of the

agreement shall be mutually agreed upon between the JMB, MC, or any relevant parties and the developer.

**5.1.2 Phase 2: Post development**

The development area designed with pole infrastructure and connected to the NFP pole shall be constructed as shown in Figure 3. The distance of the first pole that will connect with the NFP pole shall be placed as close as possible, with a maximum of 50 m from the NFP pole. For any requirement for additional poles outside PPL, the developer may discuss with NFP through a commercial arrangement for the best option. A proper handover agreement shall be carried out between the developer and NFP upon completion of the construction.

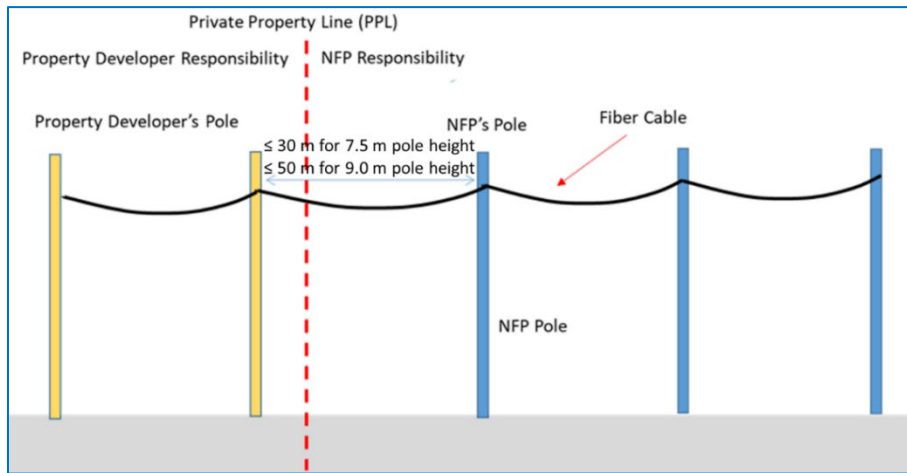

**Figure 3. Overhead connection with NFP's pole**

The development area designed with pole infrastructure and connected to NFP's underground infrastructure shall be constructed as shown in Figure 4. The developer shall install a common access manhole next to the first developer's pole, and the NFP will provide the infrastructure connecting the NFP manhole to this common access manhole. For any cases where PPL changes due to any development, the common access manhole status remains unchanged.

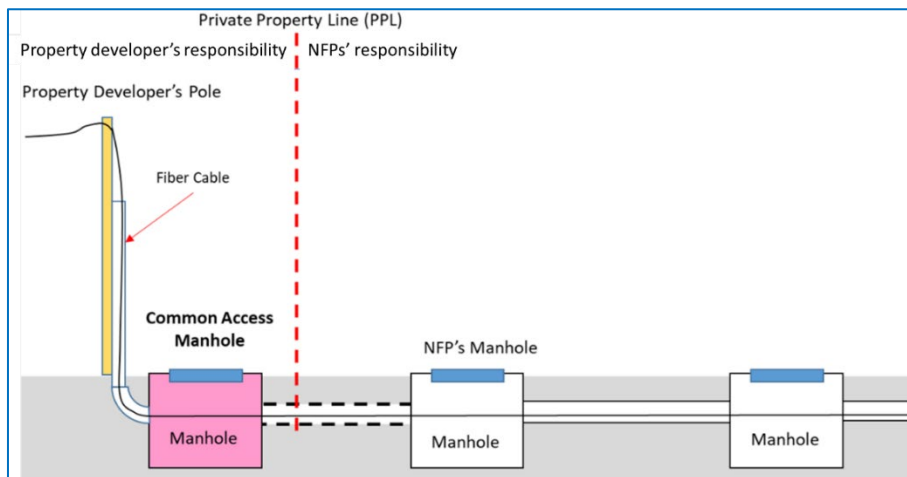

**Figure 4. Overhead connection for pole type deployment**

5.2 Pole distribution design

Only the landed residential SDU is recommended to be served via pole. Industrial or commercial properties are highly recommended to be served with underground infrastructure for the premises access connection.

The development area designed with pole infrastructure for connection via NFP's pole shall be prepared as shown in Figure 5.

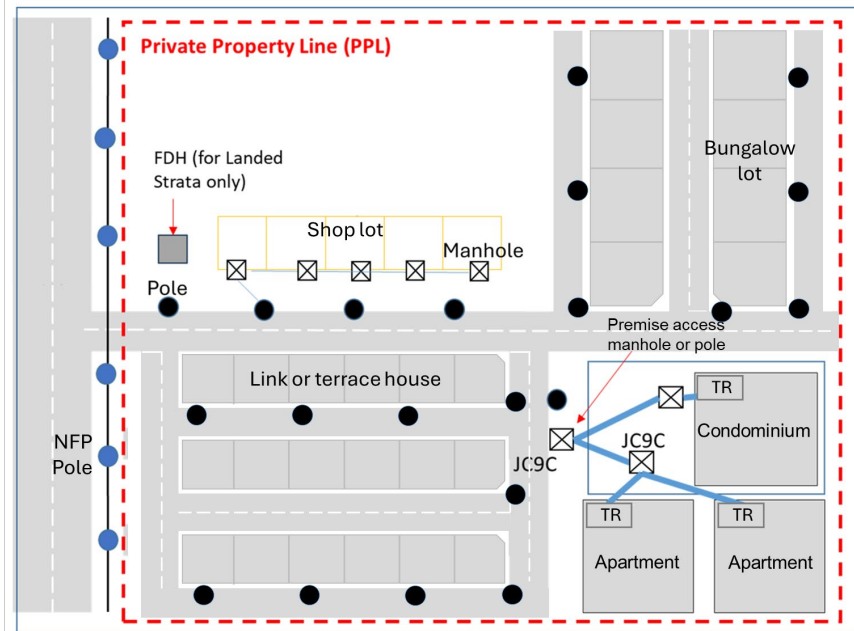

Figure 5. Pole distribution for connection via NFP's pole

The development area designed with pole infrastructure for connection via NFPs' underground infrastructure shall be prepared as shown in Figure 6.

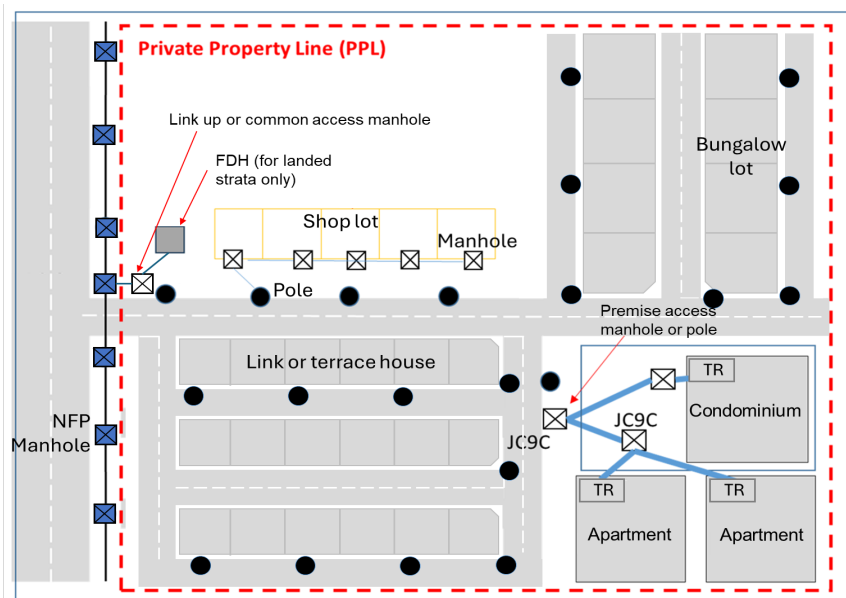
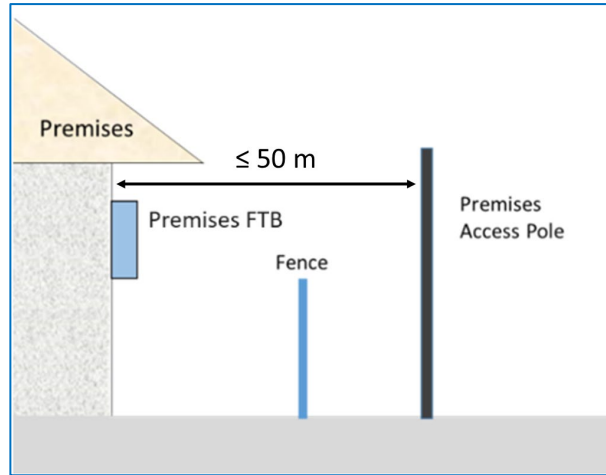

Figure 6. Pole distribution for connection via NFP's underground infrastructure

**5.3 Premises access pole**

Premises access pole refers to the pole that is used to connect to the customer premises. Each pole shall be positioned within a maximum distance of 50 m from the serviceable premises shown in Figure 7. The distance shall be measured between the pole and the premises Fibre Termination Box (FTB).



**Figure 7. Premises access pole**

For scattered developments or rural areas where the distance exceeds 50 m, it is recommended that NFP install an intermediate pole to support the cable. For poles placed on private land, permission from the landowner is required.

**5.4 Planning in greenfield and brownfield infrastructure area**

**5.4.1 Planning in greenfield infrastructure area**

The property developer or the appointed NFP (e.g., Telco A) shall ensure that all poles installed within the PPL use either the CP7.5-14-2.0kN or CP9.0-14-2.0kN pole types, as specified in Table 1.

**Table 1. Shareable pole specifications**

Pole type	Length (m)	Depth (m)	Height (m)	Diameter		Design load (kN), safety factor: 2	Max span (m)	Applications area
				Top (m)	Bottom (m)			
CP7.5-10-1.1kN	7.5	1.3	6.2	0.10	0.175	1.1	30	Premises access pole
CP7.5-14-2.0kN	7.5	1.3	6.2	0.14	0.240	2.0	30	
CP9.0-14-2.0kN	9.0	1.5	7.5	0.14	0.260	2.0	50	a) Road crossing b) High clearance path

These pole types are designed to support infrastructure sharing among multiple NFPs. NFPs providing last-mile services are encouraged to supply the necessary infrastructure to ensure service continuity and to safeguard public interest.

## MCMC MTSFB TC G025-5:2025

The detailed specifications for external infrastructure requirements are described in MCMC MTSFB TC G024.

Subsequent new NFPs, such as Telco B and Telco C, shall use the existing pole infrastructure. However, Telco B and Telco C shall construct their own FDCs, Fibre Distribution Panels (FDPs), and Fibre Optic Closures (FOCs) while adhering to the pole sharing specifications and procedure established by Telco A and/or the property developer.

The new NFP shall follow the pole sharing specifications, procedure, and commercial arrangements established by the existing NFP.

Figure 8 illustrates the pole sharing arrangement in a greenfield area.

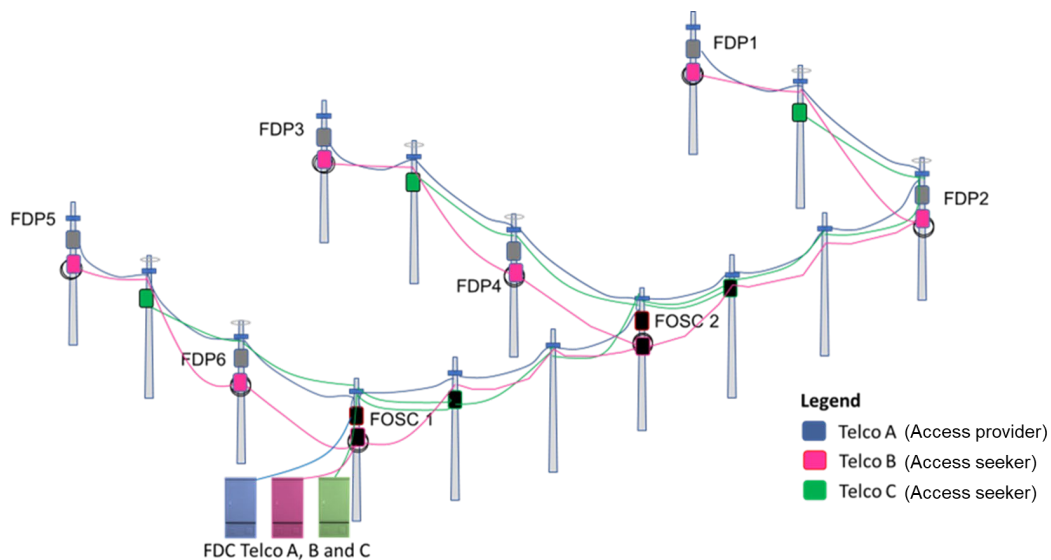

**Figure 8. Shareable pole infrastructure in greenfield area**

### 5.4.2 Planning in brownfield infrastructure area

There are 2 scenarios for planning in a brownfield infrastructure area.

#### 5.4.2.1 Scenario A: Existing pole infrastructure is not using the pole sharing specification

The existing brownfield area, which does not use the pole specification as specified in Table 1, is not allowed for pole sharing requirements.

The subsequent Telco B and Telco C, who plan to provide the service in the same brownfield area, shall construct new pole infrastructure using CP7.5-14-2.0kN specifications.

Figure 9 illustrates the pole planning in a brownfield infrastructure area where existing pole infrastructure does not use the pole sharing specification.

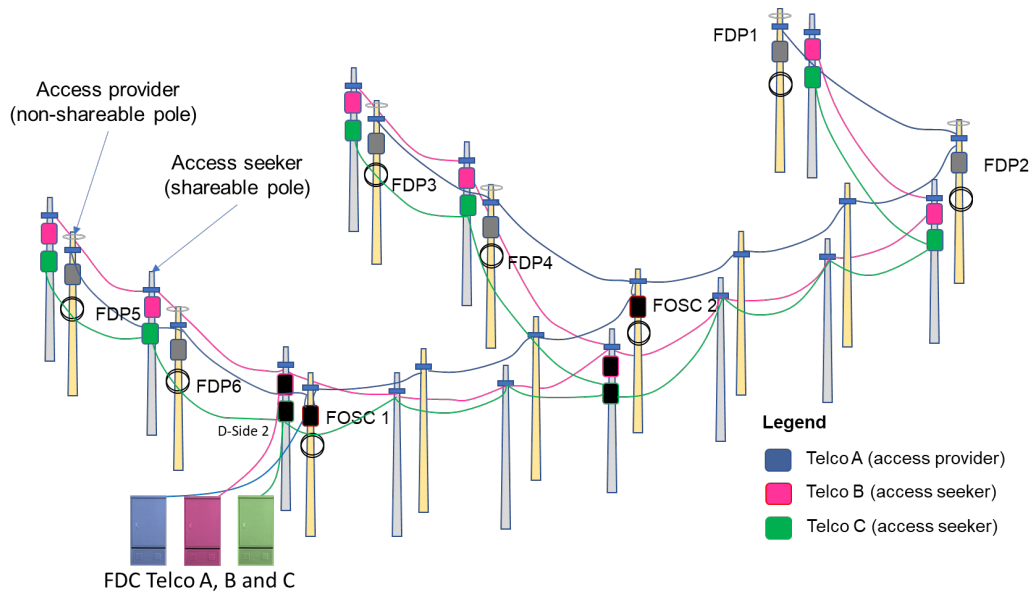

**Figure 9. Pole planning in brownfield infrastructure area for scenario A**

**5.4.2.2 Scenario B: Existing pole infrastructure using pole sharing specification**

The specifications and designs shall be in accordance with the requirements specified in the clause 5.1.1. The access seeker is required to submit a formal request to the structure owner to access for such sharing.

Figure 8 illustrates the pole planning in a brownfield infrastructure area where existing pole infrastructure is using pole sharing specifications.

**6. Infrastructure requirements**

**6.1 Pole specification**

All concrete poles shall meet the specifications in accordance with JIS A5373 or other equivalent and recognised code of practice.

The specifications and installation procedures for these poles should follow the recommendations provided by NSPs and NFPs.

**6.1.1 Basic design wind speed**

The poles shall be designed for the purpose of assessing their structural strength to a basic design wind speed of 33.5 m/s (120.6 km/h), 3-second gust speed, or 22.22 m/s mean hourly wind speed for all sites. This corresponds to a return period of 1 in 50 years.

**6.1.2 Design Load**

The specifications and design load for the type of poles that can be deployed are specified in Table 1. The design of the pole shall be endorsed by the Professional Engineer with a Practicing Certificate (PEPC).

## MCMC MTSFB TC G025-5:2025

The cables installed on the shareable pole shall not surpass the design load specified in Table 1 (refer to Annex B). It is hereby recommended that the first NFP allocate a permissible load space for the benefit of the secondary NFP.

### 6.2 Pole installation

Pole installation should be parallel to the roads, residential areas, back lanes, and small alleys. The distance between adjacent poles should be referred to Table 1 and illustrated in Figure 10.

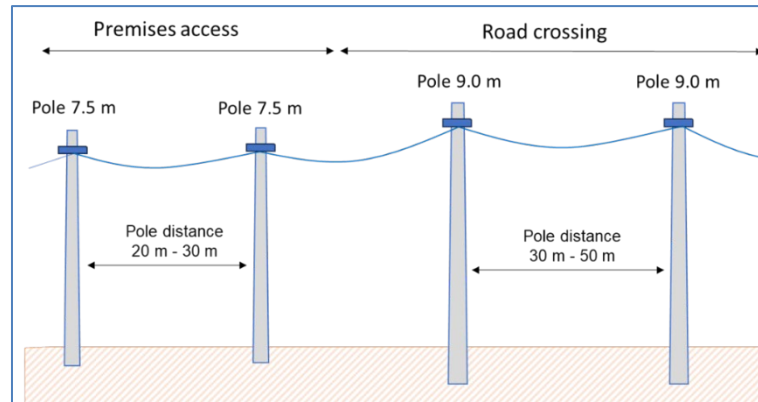

**Figure 10. Distance between poles for an even area**

For the case of slope area, the maximum difference of height between 2 poles shall be kept less than 300 mm, as illustrated in Figure 11. If the distance cannot be met, the distance between poles shall be reduced.

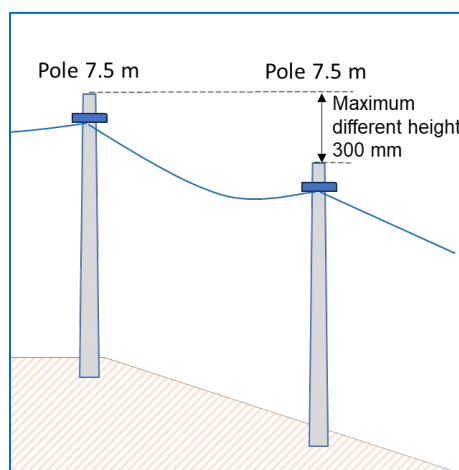

**Figure 11. Distance between poles for slope area**

The concrete kicking block should be used to support the pole when necessary. The top edge of the concrete kicking block shall be installed at 150 mm from the surface level. Figure 12 illustrates the kicking block dimension.

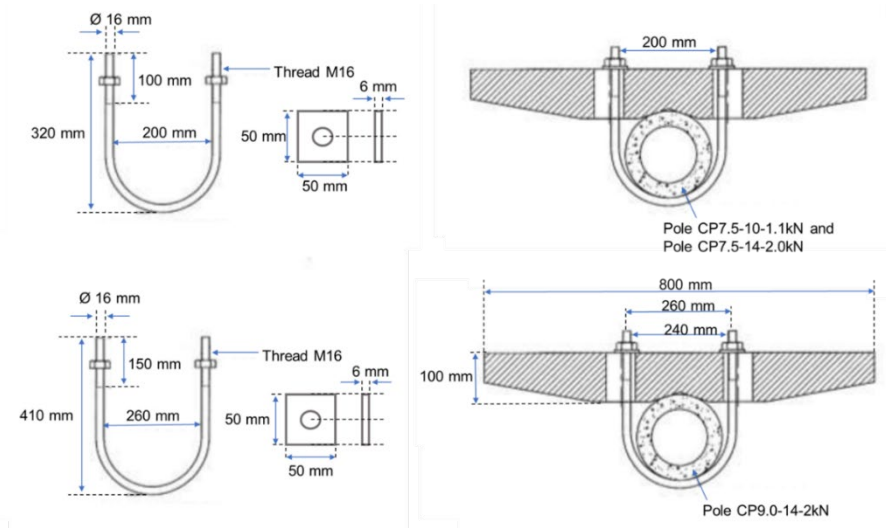

Figure 12. Concrete kicking block dimension

### 6.3 Stay wire and strut

If the installation of a stay wire or strut is required to account for changes in the alignment, it should be positioned at the beginning, at intersections, and at the end of the cable route to ensure that it does not obstruct the roadway, as illustrated in Figures 13 and 14.

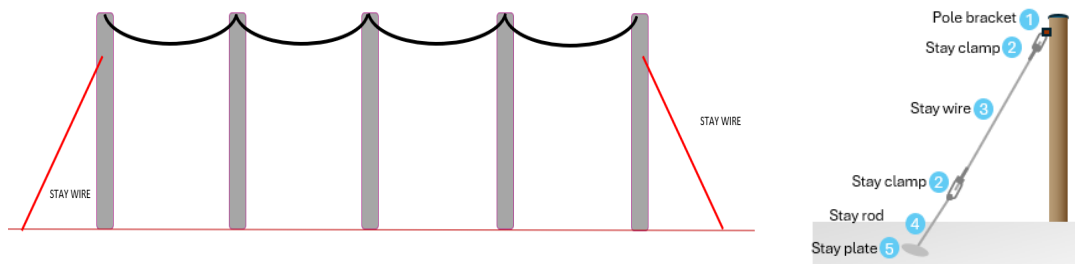

Figure 13. Stay wire installation method

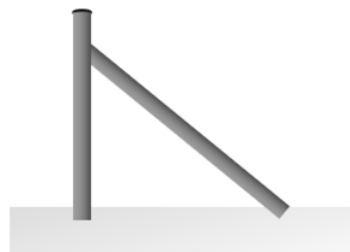

Figure 14. Strut installation method

If the installation of the stay wire or strut requires reassessment, it is essential to ensure that the installation does not disrupt the public or hinder the maintenance work being conducted in the area.

### 6.4 Pole marking

Each pole shall be labelled or marked to indicate below information as per Table 2.

**Table 2. Label or marking requirement on pole**

Label or marking	Responsibilities
Pole owner logo or name	NFP
Asset number or identification	
Contact number	
Pole length	Supplier
Pole design load	
Pole standard	
Manufacturing date	
Embedded length marking	
Centre of gravity	

### 6.5 Accessibility

Only authorised personnel by the NFP shall be allowed to access the pole and its equipment. The property owner shall establish a controlled procedure to allow access to those infrastructures. The access seeker is required to submit a formal request to the access provider before accessing the pole. Any arrangement for on-site access should be agreed upon by both parties, as spelled out in the Commission Determination on the Mandatory Standard on Access, Determination No. 1 of 2022, or its subsequent Determinations.

## 7. Cabling requirements

Fibre cables installed on poles shall be routed and secured properly to ensure aesthetics and functionality.

### 7.1 Cables positioning

To ensure the correct and efficient installation of fibre optic cables, it is essential to pay close attention to the placement of cables, accessories and fittings on poles. Proper spacing not only facilitates maintenance but also minimises the risk of interference or damage to the cables. Figure 15 illustrate the cables position on the poles.

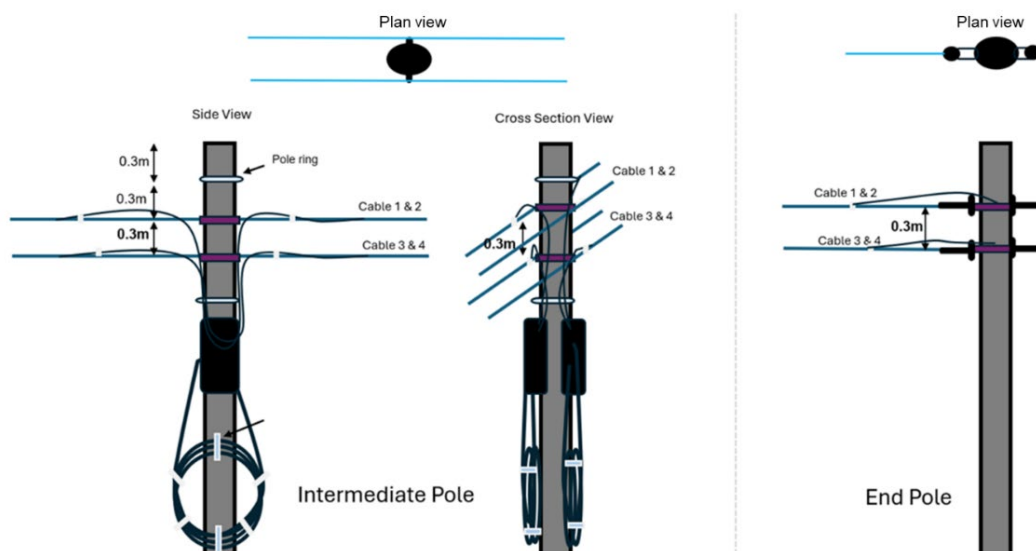

**Figure 15. Cables position at pole**

For a detailed understanding of the recommended distances and arrangements, please refer to Figure 16. This illustration provides visual guidance on the appropriate spacing between various accessories and fittings, helping to standardise installation practices. Adhering to these guidelines will promote a safer and more organised installation, ensuring optimal performance of the fibre optic network.

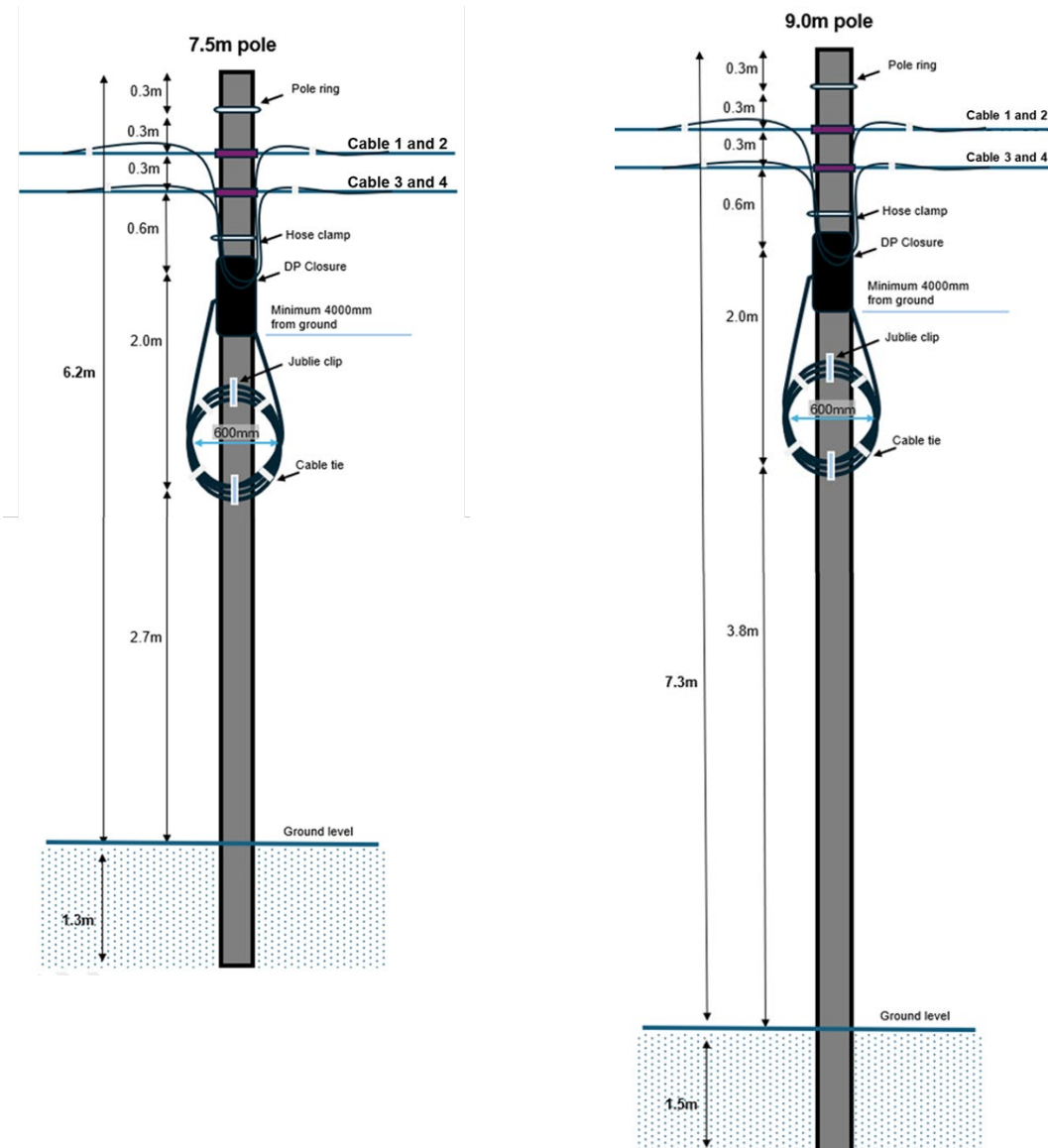

**Figure 16. Spacing between various accessories and fittings**

## 7.2 Splice closure positioning

As illustrated in Figure 17, dome-type splice closures for aerial fibre optic cables shall maintain at a minimum clearance of 4 m from the ground. When securing cable coils that have a diameter of 600 mm, stainless steel cable ties shall be used for appropriate fixation.

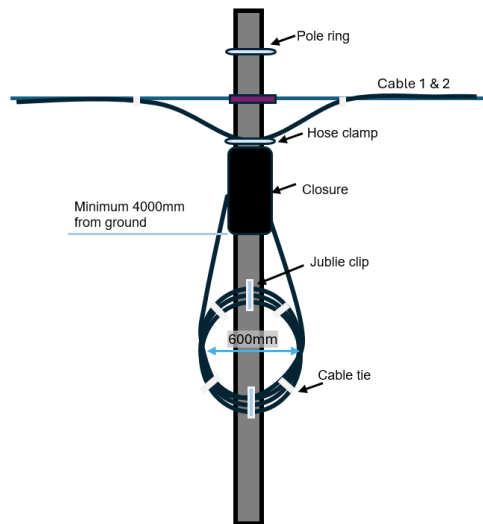

Figure 17. Position of dome-type closure and cable coil

**7.3 Optimal distances between cables**

Optimal cable spacing depends on cable size, type, operator requirements, and pole load capacity. Standard single-fiber cables shall be spaced at a minimum distance of 300 mm (0.3 m).

**7.4 Cable organisation and maintenance**

To maximise service performance and minimise potential cable damage or clutter, use the nearest pole ring to systematically manage and drop cables to the nearest premises. This strategy promotes a well-organised setup and facilitates easier maintenance access.

Figure 18 illustrates an example of how the drop cable from the nearest pole to the premises.

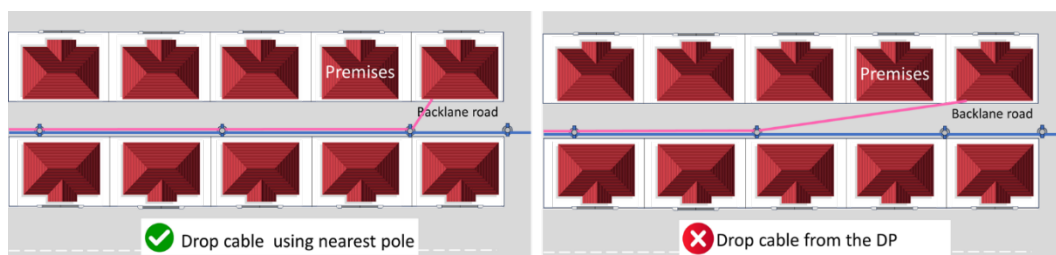

Figure 18. Drop cable from the nearest pole

**7.5 Distribution Points (DP)**

The number of Distribution Points (DP) per pole shall be limited to a maximum of two, and with a maximum of two cable coils per pole. Each subsequent distribution point should be positioned on the next available pole to maintain a clean and organised appearance of the installation.

Figure 17 illustrates the position of the DP closure and cable coil.

**7.6 Cable sag**

For spans measuring between 40 m and 50 m, a targeted cable sag of approximately 1 m is recommended, equating to a sag of about 2% relative to the pole-to-pole distance as illustrated in Figure 19.

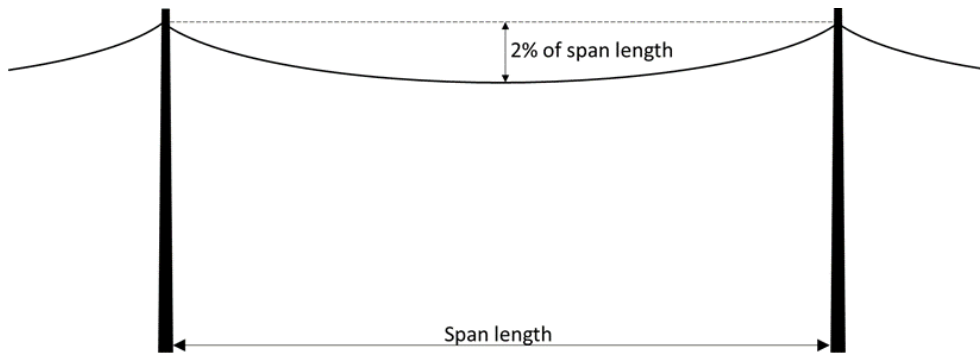

**Figure 19. Cable sagging**

**7.7 Distance between power and telecommunication cables**

The minimum clearance distances between fibre cables and electricity cables, including cable crossings, are stipulated in the Electricity Supply Act, 1990 (ACT 447), P.U.(A) 38/94 Electricity Regulations, 1994, and are tabulated in Table 3.

**Table 3. Minimum clearance distances between fibre cables and electricity cables**

Voltage level	Electricity cable type	Other cable type	Minimum Clearance Distance (m)
Low voltage (415 V)	-	Any cable	2.134
High or very high voltage (above 11 kV)	Non-insulated	Any non-insulated cable	9.15
	Insulated	Fibre cable	4.57
Any voltage	-	Fibre cable crossing an electricity cable	1.2

Note: Barrier required if the distance is below 1.2 m. However, in most situations, the barrier is very difficult to install. It is recommended to use underground cable when the crossing distance is less than 1.2 m.

**8. Installation works for Fibre Distribution Cabinets (FDC)**

**8.1 General requirement**

To ensure seamless connectivity and customer satisfaction, NFP or NSP shall ensure that all last-mile distribution cabling and FDCs are provisioned with enough number of fibre ports for each house unit, ready for activation and deployment. This means that each house unit shall be allocated a corresponding number of fibre ports in the FDCs, allowing for efficient and reliable data transmission.

The pre-assignment of fibre ports shall be done in a manner that minimises the risk of errors or misconnections, ensuring that customers can access high-speed internet and other services without disruption.

NFP or NSP shall maintain accurate records of the fibre port allocation and availability, to enable swift troubleshooting and resolution of any issues that may arise.

**8.1.1 Temporary Occupation License (TOL) application**

NFP is required to submit a Temporary Occupation License (TOL) application to the District and Land Office for the installation of fibre distribution cabinets on government land.

## MCMC MTSFB TC G025-5:2025

The following payments are required.

- a) permit of work; and
- b) TOL fee.

### 8.1.2 Approval for Fibre Distribution Cabinets (FDC)s construction on local authority road reserve

If the construction of the FDC is located on the local authority (*Pihak Berkuasa Tempatan* (PBT)) road reserve, the NFP shall obtain approval from the local authority (PBT) or local council (*Pihak Berkuasa Meluluskan* (PBM)).

### 8.2 Fibre Distribution Cabinet (FDC) requirement

When installing FDC, it is essential to adhere to specific guidelines to ensure safety, functionality, and compliance with local regulations. For a proper installation and placement of FDC, it shall be:

- a) installed neatly and in an organised manner;
- b) not hinder traffic flow or pedestrian pathways;
- c) made from non-corrosive or treated metallic material to resist corrosion and harsh environments;
- d) installed at the location by approval from PBT or PBM, including the following:
  - i) it should not obstruct sightlines at vehicle entry and exit intersections;
  - ii) shall not be installed in front of any residential doors or premises; and
  - iii) built along pedestrian walkways, ensure a clearance distance from the road edge.

The example of FDC is illustrated in Figure 20.

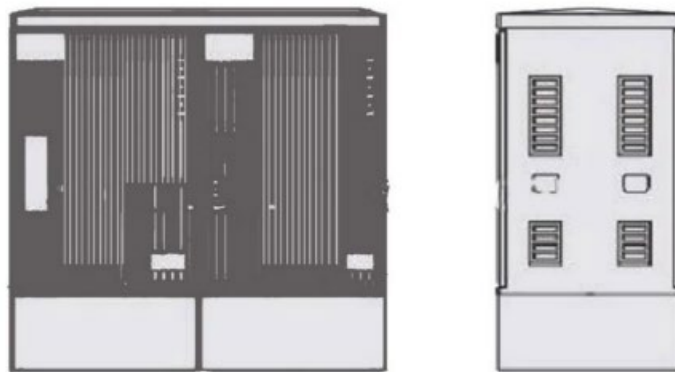

Figure 20. Example of FDC

## 9. Excavation works

Proper excavation works for installing poles are crucial for structural integrity, safety, compliance with regulations, and long-term upkeep. Environmental factors must also be considered. NFP or NSP shall perform earth excavation and road resurfacing neatly and systematically.

## **MCMC MTSFB TC G025-5:2025**

The method for installing a concrete pole is direct embedment. The pole shall be positioned within an augured hole lined with gravel, which shall then be refilled with the original soil or concrete, depending on the current soil conditions. If necessary, it is recommended to consult with a PEPC to review the soil condition.

The poles shall be buried sufficiently deep for stability. The depth depends on the type of pole, as shown in Table 1.

The requirements for earth excavation from FDC cabinets to poles are as follows:

- a) damaged roads or road shoulders shall be repaired according to the original specifications (imprint, interlocking, premix, concrete, grass); and
- b) if fibre cables need to cross roads via open trench, micro trench, and Horizontal Directional Drilling (HDD) method, the road shall be resurfaced using the "mill and pave" method. The resurfacing should be done promptly.

Details of the excavation works shall refer to MCMC MTSFB TC G025.

### **10. Infrastructure and cabling acceptance procedure**

The procedure shall be according to the requirements specified in MCMC MTSFB TC G024.

### **11. Safety and precaution**

The safety and precaution shall be according to the requirements specified in MCMC MTSFB TC G024.

A traffic management plan, as specified in MCMC MTSFB TC G025-1, shall be developed and implemented to ensure the safe diversion, slowdown, or stoppage of traffic in the vicinity of the work area.

**Annex A**  
(informative)

**Abbreviations**

BM	Bending Moment
CO	Central Office
DP	Distribution Point
DSL	Digital Subscriber Line
D-Side	Distribution Side
E-Side	Exchange Side
FDC	Fibre Distribution Cabinet
FDH	Fibre Distribution House
FDP	Fibre Distribution Panel
FOC	Fibre Optic Closure
FOSC	Fiber Optic Splice Closure
FTB	Fibre Termination Box
FTTC	Fibre-to-the-Curb
FTTH	Fibre-to-the-Home
FTTP	Fibre To The Premises
HDD	Horizontal Directional Drilling
JMB	Joint Management Building
MC	Management Corporation
MDU	Multi-Dwelling Unit
NFP	Network Facilities Provider
NSP	Network Service Provider
ONT	Optical Network Terminals
PBM	<i>Pihak Berkuasa Melulus</i>
PBT	<i>Pihak Berkuasa Tempatan</i>
PEPC	Professional Engineer with Practicing Certificate
PPL	Private Property Line
PSTN	Public Switched Telephone Network
SDU	Single Dwelling Unit
Sub-MC	Subsidiary Management Corporation
TOL	Temporary Occupation License
TR	Telecommunication Room

## Annex B (normative)

### Calculation for number of cables on poles

#### B.1 Introduction

To calculate the number of cables on poles, the following loads, Pole Wind Load ( $F_{pw}$ ) and Aerial Cable Wind Load ( $F_{aw}$ ), shall be considered.

These loads are expected to be applied to a pole in order to determine the pole's strength requirements to sustain the loads. These loads are simultaneously applied to poles in the horizontal directions.

The poles need to have sufficient strength such that the following relationship is satisfied:

$$F_{pw} + F_{aw} \leq F_{DL}$$

Where,

$F_{pw}$  is the Wind load acting on the pole (kN)

$F_{aw}$  is the Wind load aerial cable acting on the pole (kN)

$F_{DL}$  is the Pole design load (kN)

#### B.2 Wind load

Wind load is the effect of wind on buildings, structures, and other objects. It is caused by wind pressure, air speed, and wind velocity.

Wind pressure is the overall force applied upon a structure by wind. In the case of it being a flat surface, it includes two main elements, the primary being the energetic weight applied on the windward side of the surface, referred to as wind load.

The strength of the wind load depends on the magnitude of the wind speed.

In order to prevent structural collapse, the pole's structural design must securely and efficiently absorb wind forces and convey them to the foundations.

##### B.2.1 Basic design wind speed ( $V_s$ )

The basic wind speeds are usually taken at 10m height above ground at all meteorological stations and are used as the reference wind speed considered in the calculation of design load to building structure.

The basic wind speed ( $V_s$ ) = 33.5 m/s (120.6 km/h) 3 3-second gust speed or 22.22 m/s mean hourly wind speed for all sites. This corresponds to a return period of 1 in 50 years.

##### B.2.2 Wind pressure ( $p_d$ )

Wind pressure refers to the intensity of force that wind applies to a structure and is measured in Pascals (1 Pascal = 1 N/m<sup>2</sup>).

Table B.1 shows the lists of values for wind pressure versus height generated from ASCE 7, which is recommended to be used in all wind load calculations of this Technical Code. The value generated based on the following Table B.2 common data.

**Table B.1. Wind pressure versus height**

$p_d$ (kN/m <sup>2</sup> )	Height (m)
0.364516	0
0.364516	4.572
0.373892	5.158154
0.38246	5.744308
0.390364	6.330462
0.39771	6.916615
0.40458	7.502769
0.411038	8.088923
0.417137	8.675076
0.422918	9.26123

**Table B.2. Common data in generating the wind pressure values**

Items	Details
Building Classification Category	Category IV
Basic Wind Speed	33.5 m/s
Exposure Category	Exposure C
Structure Type	Chimney, tank, and similar structure

**B.2.3 Wind load pole ( $F_{pw}$ )**

The pole manufacturer shall provide the wind load information based on the basic wind speed and wind pressure in the above.

If the information is not made available, the following step of calculation can be used as guidance.

**a) Step 1, calculate the Bending Moment (BM)**

The Bending Moment (BM) due to wind on the pole at ground level:

$$BM = p_d \times P_h^2 \times (C_{pgl} + 2 \times C_{pt}) / 6\pi \times \text{overload capacity factor}$$

Where,

$p_d$  is wind pressure

$P_h$  is Pole height

$C_{pgl}$  is pole circumference at ground level

$C_{pt}$  is pole circumference at top

$6/\pi$  is calculation constant

Overload Capacity Factor taken as 1.75.

**b) Step 2, calculate the equivalent wind load acting on pole at the load point**

$$F_{pW} = BM / (P_h - P_{lp})$$

Where,

$P_{lp}$  is pole load point

**B.2.4 Wind load aerial cable ( $F_{aW}$ )**

$F_{aW}$  is the horizontal load acting on a pole (loading position), arising from wind at right angles to the span of the cables. It shall be calculated from the following equation:

$$F_{aW} = p_d . d_c . k_e . L_w \text{ (kN)}$$

Where,

$p_d$  is the design wind pressure in kN/m<sup>2</sup>

$d_c$  is nominal external diameter of the cable, in meters

$k_e$  is a span factor, taken as equal to 1.0

$L_w$  is the wind span

$$L_w = (L_1 + L_2)/2$$

$L_1$  is pole span of the adjacent pole on the left side

$L_2$  is the adjacent pole on the right side

**B.3 Calculation example**

Given pole data and aerial cable as per Table B.3 and Table B.4 respectively, and the pole span is 30 m. Calculate the total wind load acting on the pole and determine if the numbers of cables exceed the pole design load.

**Table B.3 Pole data**

Concrete Pole Type	CP 7.5-10-1.1kN
Pole Design $P_{DL}$ Load (kN)	1.1
Pole height $P_h$ (m)	6.2
Pole Depth $P_d$ (m)	1.3
Taper	0.01
Pole Bottom Diameter $P_{bd}$ (m)	0.175
Pole Diameter at Ground Level $P_{gl}$ (m)	0.161
Pole Top Diameter $P_t$ (m)	0.100
Pole Loading Point from Top $P_{lp}$ (m)	0.300

Table B.4. Types of fibre optic cable

NFP	Cable Illustration	Fibre Optic Cable Type (IB)	Nominal external diameter of the cable, $d_c$ (m)
A	See Figure B.1	144C	0.0240
B	See Figure B.2	144C	0.0164

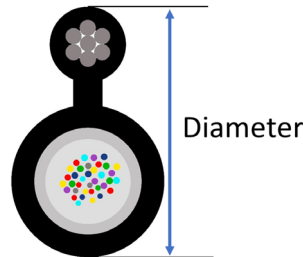

Figure B.1. Example of fibre optic cable type for NFP A

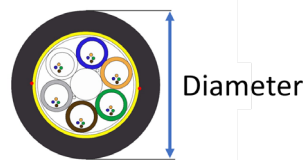

Figure B.2. Example of fibre optic cable type for NFP B

**Calculation steps,**

- a) **Step 1**, calculate the circumference at the pole top and at the pole ground level

$$C_{pgl} = \pi P_{gl} = 0.161\pi \text{ m}$$

$$C_{dt} = \pi P_t = 0.100\pi \text{ m}$$

- b) **Step 2**, calculate Bending Moment (BM)

The bending moment ( $BM$ ) due to wind on pole at ground level:

$$\begin{aligned}
 BM &= p_d \times P_h^2 \times (C_{pgl} + 2 \times C_{pt})/6\pi \times \text{overload capacity factor} \\
 &= (0.390364 \text{ kN/m}^2) \times (6.2\text{m})^2 \times [(0.161\pi + (2 \times 0.100\pi))/6\pi] \text{ m} \times 1.75 \\
 &= (0.390364) \times (38.44) \times (1.137257)/6 \times (1.75) \text{ kN.m} \\
 &= 1.584 \text{ kN.m}
 \end{aligned}$$

- c) **Step 3**, calculate the equivalent wind load acting on pole at the load point

$$\begin{aligned}
 F_{pW} &= BM / (P_h - P_{lp}) \\
 &= 1.584 / (6.2 - 0.3) \text{ kN} \\
 &= 1.584 / 5.9 \text{ kN} \\
 &= 0.268 \text{ kN}
 \end{aligned}$$

**d) Step 4, calculate wind load on aerial cables for NFP A and NFP B**

For NFP A,

$$\begin{aligned} F_{aW} &= p_d \cdot d_c \cdot k_e \cdot L_w \text{ (kN)} \\ &= (0.390364 \text{ kN/m}^2) \times (0.024 \text{ m}) \times 1 \times (30 \text{ m}) \\ &= 0.281 \text{ kN} \end{aligned}$$

For NFP B,

$$\begin{aligned} F_{aW} &= p_d \cdot d_c \cdot k_e \cdot L_w \text{ (kN)} \\ &= (0.390364 \text{ kN/m}^2) \times (0.0164 \text{ m}) \times 1 \times (30 \text{ m}) \\ &= 0.201 \text{ kN} \end{aligned}$$

Total aerial wind load cable

$$\begin{aligned} &= 0.281 \text{ kN} + 0.201 \\ &= 0.482 \text{ kN} \end{aligned}$$

**e) Step 5, calculate the total wind load for both poles and cables**

$$F_{pW} + F_{aW} = 0.268 \text{ kN} + 0.482 \text{ kN} = 0.75 \text{ kN}$$

The value  $0.75 \text{ kN} \leq 1.1 \text{ kN}$ ; hence the pole type CP75-10-1.1 has strength requirements to sustain the wind load acting on the pole and the wind load of cables in Table B.4.

## **Bibliography**

- [1] *Commission Determination on Access List, Determination No. 6 of 2021, or its subsequent Determinations*
- [2] *MS 1553, Code of practice on wind loading for building structure*
- [3] *AZ/NZS 4676, Structural design requirements for utility services poles*
- [4] *NESC C2-2017, National Electrical Safety Code*

## **Acknowledgements**

### **Members of the Fixed Network Facilities Working Group**

#### **Working Group Leaders**

Ts Amir Subhi Wan Omar (Chair)	TM Technology Services Sdn Bhd
Mr Zulkefli Zabri (Vice chair)	Maxis Broadband Sdn Bhd
Ir Dr Anas Abdul Latiff (Secretary)	Universiti Teknikal Malaysia Melaka

#### **Drafting Committee Members**

Mr Eami Yusry Mohd Yusof (Draft lead)	Maxis Broadband Sdn Bhd
Mr Nazar Mohd Nong (Co draft lead)	TM Technology Services Sdn Bhd
Mr Muhaimin Mat Salleh (Secretariat)	Malaysian Technical Standards Forum Bhd
Mr Mohamed Azli Ab Jalil	Maxis Broadband Sdn Bhd
Mr Zulkefli Zabri	Maxis Broadband Sdn Bhd
Mr Mohd Mokhtar Daud	Malaysia Digital Economy Corporation Sdn Bhd
Mr Amirahmad Khamesipour	PMW Concrete Industries Sdn Bhd
Mr Yusof Yeop Ahmat	PMW Concrete Industries Sdn Bhd
Ts Amir Subhi Wan Omar	TM Technology Services Sdn Bhd
Ts Sufian Sulaiman	TM Technology Services Sdn Bhd
Mr Aminnurrashid Abd Manaf	TT Dotcom Sdn Bhd
Mr Salleh Husin	TT Dotcom Sdn Bhd
Ir Dr Anas Abdul Latiff	Universiti Teknikal Malaysia Melaka
Prof Ir Dr Badrul Hisham Ahmad	Universiti Teknikal Malaysia Melaka

#### **Contributors**

Mr Zulkeple Saari	Asaascom Engineering Sdn Bhd
Mr Muhammad Rezza Alui	CelcomDigi Berhad
Mr Peter Barry Macaulay	CelcomDigi Berhad
YM Raja Zahiruddin Raja Muda	CelcomDigi Berhad
Mr Mohd Kasyful Azim Ab Rahman	Maxis Broadband Sdn Bhd
Mr Prakash Anbalagan	Maxis Broadband Sdn Bhd
Mr Leong Woon Min	Redsun Engineering Sdn Bhd
Ms Norhanisah Mohd Basri	SIRIM Berhad
Ts Mohd Zulfadzli Abu Seman	SIRIM Berhad
Mr Yousri Taibin	Terengganu Telecommunications Sdn Bhd
Mr Abdul Ghani Abdul Jalil	TM Technology Services Sdn Bhd
Mr Ahmad Fizri Mohd Azmi	TM Technology Services Sdn Bhd

## **MCMC MTSFB TC G025-5:2025**

Mr Ahmad Noor Zaini Mohammad Zaibi	TM Technology Services Sdn Bhd
Mr Ahmad Shahril Abu Bakar	TM Technology Services Sdn Bhd
Ms Erliz Rizuan	TM Technology Services Sdn Bhd
Ms Hana Afita Shahar	TM Technology Services Sdn Bhd
Mr Mohammed Ariffadlullah Md Shariff	TM Technology Services Sdn Bhd
Mr Mohd Fahmi Hassim	TM Technology Services Sdn Bhd
Ms Fatimah Salwani Ramli	TM Technology Services Sdn Bhd
Mr Mohd Fuad Turiman	TM Technology Services Sdn Bhd
Mr Mohd Nizam Osman	TM Technology Services Sdn Bhd
Mr Mohd Saiful Azim Mohd Safian	TM Technology Services Sdn Bhd
Mr Mohd Saiful Shapiai	TM Technology Services Sdn Bhd
Mr Nor Hafiz Mohd Razali	TT Dotcom Sdn Bhd
Mr Ahmad Nasri Zakaria	U Mobile Sdn Bhd
Dr Muhammad Yusof Mohd Noor	Universiti Teknologi Malaysia
<i>Mr Muhamad Imran Muhamad Zulkifli</i>	<i>Allo Technology Sdn Bhd</i>
<i>Mr Awi Shahadan</i>	<i>Desjaya Concrete Sdn Bhd</i>
<i>Ir Che Mimi Suriyani Ismail</i>	<i>Jabatan Kerja Raya Malaysia</i>
<i>Mr Mohd Ismail Ahmad Sabri</i>	<i>Majlis Bandaraya Seberang Perai</i>
<i>Mr Mustaqin Alpi</i>	<i>Pejabat Setiausaha Kerajaan Negeri Pulau Pinang</i>