

MCMC MTSFB TC G055:2025

# TECHNICAL CODE

## FIXED NETWORK FACILITIES - IN-BUILDING AND EXTERNAL FOR BROWNFIELD

Developed by



Registered by



Registered date: 20 November 2025

© Copyright 2025

## **MCMC MTSFB TC G055:2025**

### **Development of technical codes**

The Communications and Multimedia Act 1998 (Laws of Malaysia Act 588) ('the Act') provides for a Technical Standards Forum designated under Section 184 of the Act or the Malaysian Communications and Multimedia Commission ('the Commission') to prepare a technical code. The technical code prepared pursuant to Section 185 of the Act shall consist of, at least, the requirements for network interoperability and the promotion of safety of network facilities.

Section 96 of the Act also provides for the Commission to determine a technical code in accordance with Section 55 of the Act if the technical code is not developed under an applicable provision of the Act and it is unlikely to be developed by the Technical Standards Forum within a reasonable time.

In exercise of the power conferred by Section 184 of the Act, the Commission has designated the Malaysian Technical Standards Forum Bhd (MTSFB) as a Technical Standards Forum which is obligated, among others, to prepare the technical code under Section 185 of the Act.

A technical code prepared in accordance with Section 185 shall not be effective until it is registered by the Commission pursuant to Section 95 of the Act.

For further information on the technical code, please contact:

#### **Malaysian Communications and Multimedia Commission (MCMC)**

MCMC HQ Tower 1  
Jalan Impact  
Cyber 6  
63000 Cyberjaya  
Selangor Darul Ehsan  
MALAYSIA

Tel : +60 3 8688 8000  
Fax : +60 3 8688 1000  
Email : [stpd@mcmc.gov.my](mailto:stpd@mcmc.gov.my)  
Website: [www.mcmc.gov.my](http://www.mcmc.gov.my)

OR

#### **Malaysian Technical Standards Forum Bhd (MTSFB)**

Level 3A, MCMC Tower 2  
Jalan Impact  
Cyber 6  
63000 Cyberjaya  
Selangor Darul Ehsan  
MALAYSIA

Tel : +60 3 8680 9950  
Fax : +60 3 8680 9940  
Email : [support@mtsfb.org.my](mailto:support@mtsfb.org.my)  
Website: [www.mtsfb.org.my](http://www.mtsfb.org.my)

**Contents**

	<b>Page</b>
Committee representation.....	iii
Foreword .....	iv
0. Introduction.....	1
1. Scope .....	1
2. Normative references .....	1
3. Abbreviations.....	1
4. Terms and definitions .....	2
5. Building types .....	2
6. Fixed network services.....	2
7. Infrastructure and cabling requirements.....	3
7.1 Infrastructure and cabling requirements for SDU.....	3
7.2 Infrastructure and cabling requirements for MDU.....	4
7.2.1 Segment A: NFP manhole to common access manhole .....	4
7.2.2 Segment B: Common access manhole to Telecommunication Room (TR) .....	6
7.2.3 Segment C: Telecommunication Room (TR) .....	7
7.2.4 Segment D: Vertical infrastructure and cabling.....	10
7.2.5 Segment E: Horizontal infrastructure and cabling.....	16
7.2.6 Segment F: Internal fibre cabling .....	22
7.3 Infrastructure and cabling requirements for strata development area .....	23
7.4 Permission to access the infrastructure .....	24
8. External infrastructure requirements .....	24
9. Cabling specifications.....	24
9.1 Cable .....	24
9.2 Cable trunking .....	24
9.2.1 Open trunking.....	25
9.2.2 Closed trunking .....	25
9.3 Duct and micro duct .....	26
9.4 Fibre Termination Box (FTB).....	26
9.5 Fibre Wall Socket (FWS).....	26
9.6 Point of entry (POE).....	26
9.7 Quality of the materials .....	26
10. Labelling and tagging .....	27
11. Testing and commissioning.....	27
12. Safety and precautions.....	27

## **MCMC MTSFB TC G055:2025**

Annex A	Normative references.....	28
Annex B	Abbreviations .....	29

## **Committee representation**

This technical code was developed by the Fixed Network Facilities Working Group of the Malaysian Technical Standards Forum Bhd (MTSFB), which consists of representatives from the following organisations:

CelcomDigi Berhad

Malaysia Digital Economy Corporation Sdn Bhd

Maxis Broadband Sdn Bhd

Redsun Engineering Sdn Bhd

SIRIM Berhad

Terengganu Telecommunications Sdn Bhd

TM Technology Services Sdn Bhd

TT Dotcom Sdn Bhd

U Mobile Sdn Bhd

Universiti Teknikal Malaysia Melaka

Universiti Teknologi Malaysia

# **MCMC MTSFB TC G055:2025**

## **Foreword**

This technical code for the Fixed Network Facilities - In-Building and External for Brownfield ('Technical Code') was developed pursuant to the Act by the Fixed Network Facilities Working Group of the Malaysian Technical Standards Forum Bhd (MTSFB).

This Technical Code shall continue to be valid and effective from the date of its registration until it is replaced or revoked.

## **FIXED NETWORK FACILITIES - IN-BUILDING AND EXTERNAL FOR BROWNFIELD**

### **0. Introduction**

Fixed Network Facilities mean the fixed infrastructure and/or optical network elements required to provide telecommunication services comprising voice, data, broadband, or interactive service networks. This includes networks based on Internet Protocols (IP), such as Internet Protocol Television (IPTV), Voice over Internet Protocol (VoIP), etc.

A fixed network may be provisioned through Point-To-Point (P2P) or Point-To-Multipoint (P2MP) network by a Network Facilities Provider (NFP). This Technical Code aims to provide guidance for the installation of fixed network facilities in brownfield areas.

Inconsistent practices among service providers in installing fixed network facilities, particularly in brownfield developments, have resulted in varied implementation approaches. This creates challenges in efforts to fiberise existing copper-based buildings, due to the lack of uniformity of common fibre specifications.

This Technical Code is intended as a reference for consulting engineers, property owners, telecommunications licensees, and other relevant stakeholders who are responsible for planning and deploying structures.

This is in line with the objective to meet the requirements of end users for any fixed network services with minimum disruptions by the service providers.

### **1. Scope**

This Technical Code specifies the requirements for in-building and external fixed network facilities for Single-Dwelling Units (SDU) and Multi-Dwelling Units (MDU) in brownfield areas, including all infrastructure and cabling.

The utility tunnel and drainage are excluded from this Technical Code.

### **2. Normative references**

The following normative references are indispensable for the application of this Technical Code. For dated references, only the edition cited applies. For undated references, the latest edition of the normative references (including any amendments) applies.

See Annex A.

### **3. Abbreviations**

For the purposes of this Technical Code, the following abbreviations apply.

See Annex B.

# MCMC MTSFB TC G055:2025

## 4. Terms and definitions

The terms and definitions in this Technical Code shall be read in conjunction with those provided in MCMC MTSFB TC G024. In addition, the following terms and definitions shall apply specifically for the purposes of this Technical Code.

### 4.1 Brownfield infrastructure area

Brownfield refers to properties or areas where modifications, upgrades, expansions, or enhancements are made to existing fixed network facilities.

### 4.2 Property developer

In relation to a development area, means any person or body of persons, by whatever name described, who develops any land for the purpose of residential, commercial, or industrial use, or a combination of such uses.

In relation to a subdivided building or land, includes the original proprietor of the lot before the subdivision and includes the executors, administrators and successors-in-title and permitted assigns of such person or body of persons, and in a case where the person or body of persons is under liquidation, includes such person or body appointed by a court of competent jurisdiction to be the provisional liquidator or liquidator.

### 4.3 Strata property

It is also known as a strata scheme, a type of subdivision in which a multi-storey building and/or subdivided land are divided into units or parcels, accessories parcels, and similar properties in the same plot of land, such as residential, commercial, or mixed development.

## 5. Building types

This Technical Code applies to the types of buildings categorised in Table 1, which outlines the applicable building classifications for the requirements specified herein.

**Table 1. Building types**

Type	SDU	MDU
Residential	Bungalow	Condominium or apartment
	Semi-detached	
	Single, double, or triple-storey terrace	
	Town house	
Commercial, industrial, or government building	Building, industrial, commercial lot, or shop house less than 6 floors	Building an industrial, commercial lot, or shop house with equal or more than 6 floors

## 6. Fixed network services

The minimum network services, also known as essential communications services, that support voice and/or broadband services.

Typical connection between NFP network and customer premises is as shown in Figure 1.

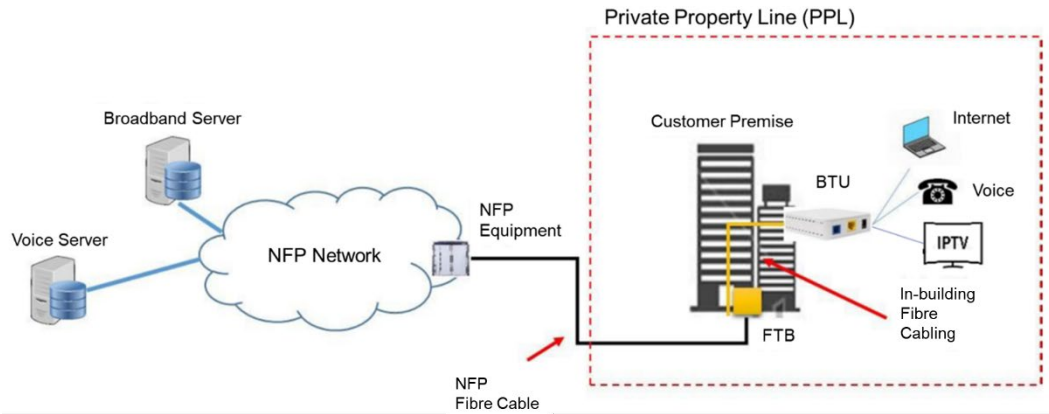

Figure 1. Typical network connection between the NFP network and the customer premises

## 7. Infrastructure and cabling requirements

The infrastructure and cabling requirements are divided into the following 2 property types as follows.

- a) SDU; and
- b) MDU.

### 7.1 Infrastructure and cabling requirements for SDU

Infrastructure and cabling requirements for the existing SDU building served by overhead distribution are as shown in Figure 2.

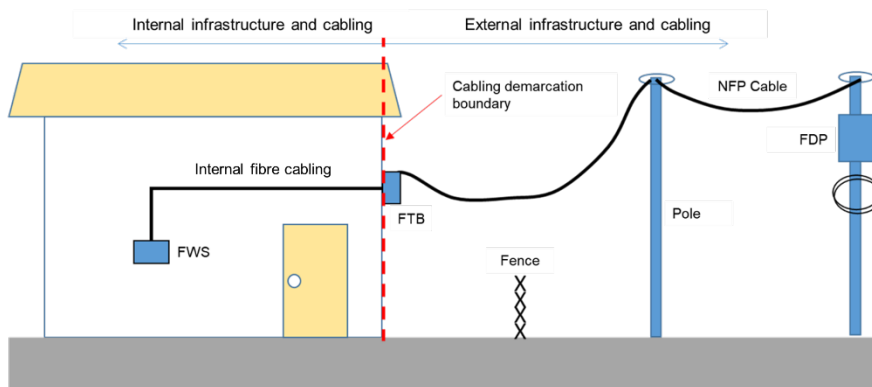

Figure 2. Infrastructure and cabling requirements for the SDU served by overhead distribution

Existing infrastructure for overhead distribution normally uses a standard pole with a non-sharing specification. Any new NFP providing services in this area shall install a new pole with specifications and design for sharing.

The detailed specifications and design for the pole sharing method are described in MCMC MTSFB TC G0xx (Pole Sharing).

Figure 3 shows the infrastructure and cabling requirements for the existing SDU building served by underground distribution.

**MCMC MTSFB TC G055:2025**

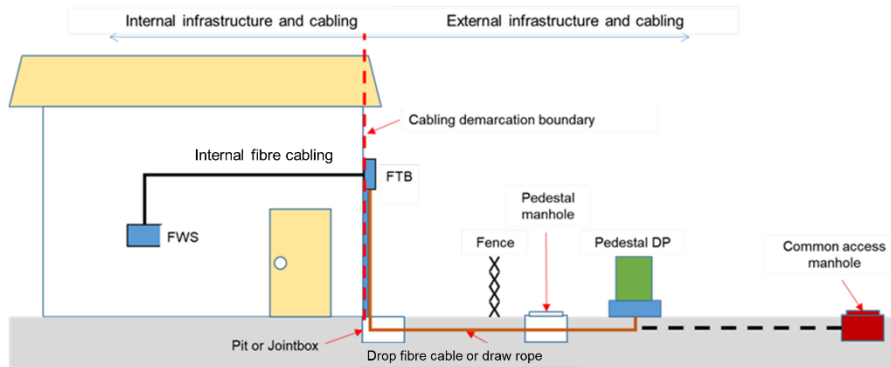

**Figure 3. Example of infrastructure and cabling requirements for SDU served by underground distribution**

Existing infrastructure for underground distribution normally uses a standard specification and can be shared with other NFPs. If the existing infrastructure is damaged or full of cables or equipment, the subsequent NFP to provide services in this area shall build new infrastructure, including manholes and ducting.

The detailed specifications for new infrastructure are as described in MCMC MTSFB TC G024.

**7.2 Infrastructure and cabling requirements for MDU**

Infrastructure and cabling requirements for existing MDU buildings are divided into 6 segments as shown in Figure 4.

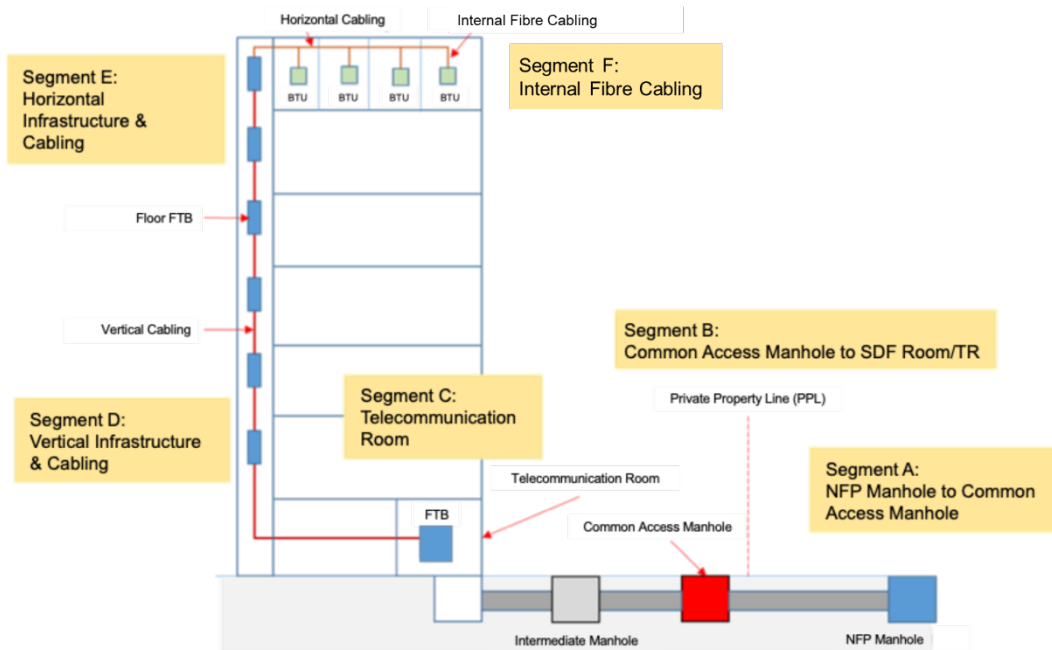

**Figure 4. Infrastructure and cabling requirements for MDU**

**7.2.1 Segment A: NFP manhole to common access manhole**

Segment A is a connection from individual NFP manhole to the common access manhole inside the property boundary, as shown in Figure 5.

**Figure 5. NFP manhole to common access manhole**

In cases where the Private Property Line (PPL) changes due to development, the common access manhole status remains unchanged.

The infrastructure involved in this segment is as follows:

- a) NFP manhole; and
- b) underground ducting to connect between the NFP manhole and the common access manhole.

The intermediate manhole links the Telecommunications Room (TR) manhole to the common access manhole and may consist of one or more units, depending on their distance apart.

**7.2.1.1 Underground duct**

NFP shall lay their own duct from its own manhole to the common access manhole. The capacity and size of the duct depend on the availability and configuration of the common access manhole. Depending on approval by the Joint Management Body (JMB) or Management Corporation (MC), the construction of an underground duct may use any of the following 3 methods:

- a) open trench;
- b) Horizontal Directional Drilling (HDD); or
- c) micro trench.

Detailed specifications of the 3 methods are specified in MCMC MTSFB TC G025.

**7.2.1.2 Common access manhole**

Specifications of the manhole and number of duct ways are tabulated in Table 2, and the examples are illustrated in Figures 6 until 9. In case the manhole is full and cannot be tapped with a new duct, the NFP may consider the following options:

- a) build a new manhole; or
- b) connect directly to the intermediate or TR manhole.

## MCMC MTSFB TC G055:2025

Both JMB or Management MC and NFP may discuss and explore the best option or method to be used.

**Table 2. Manhole size and location**

Type of manhole	Recommended internal size (mm) (L x W x D)	No. of duct way	No. of premises linked duct way	No of premises	Location or criteria
JB30	850 x 850 x 650	2	4	< 4	a) Last connection to premises unit. b) Premises access manhole.
JRC7	1 160 x 855 x 850	2	N/A	< 72	a) On a small roadside to link up with JB30. b) NFP common access manhole. c) TR linked manhole.
JC9C	1 960 x 1 260 x 1 020	4	N/A	> 576	a) On a heavy roadside to link up with JB30 or JRC7. b) NFP common access manhole. c) TR linked manhole.
R1B	1 980 x 1 370 x 1 830	6	N/A	< 576	TR or FDH linked manhole.

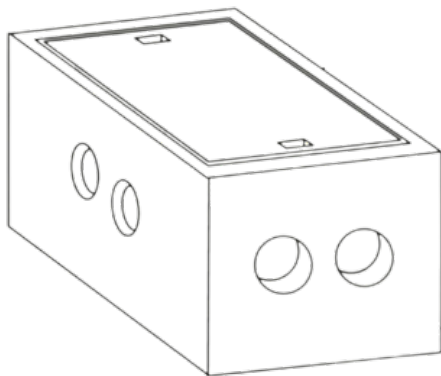

**Figure 6. Example of JB30 manhole**

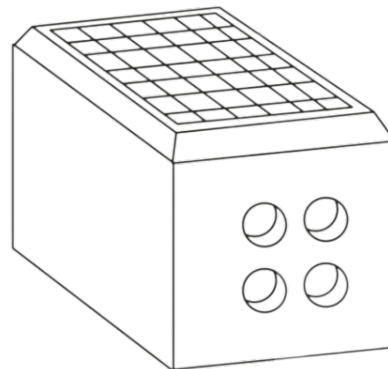

**Figure 7. Example of JRC7 manhole**

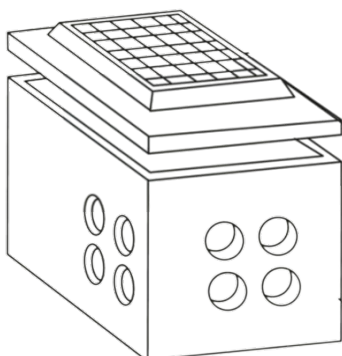

**Figure 8. Example of JC9C manhole**

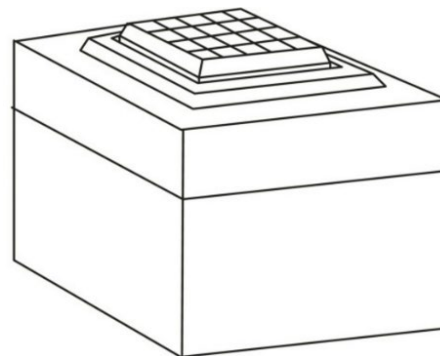

**Figure 9. Example of R1B manhole**

### 7.2.2 Segment B: Common access manhole to Telecommunication Room (TR)

Segment B covers the existing infrastructure, which consists of manholes and underground ducts built during property development, as illustrated in Figure 10.

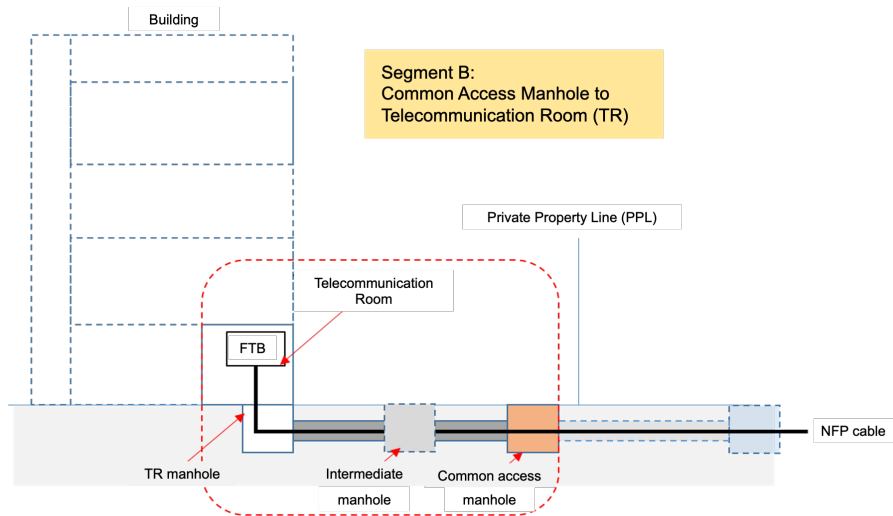

**Figure 10. Common access manhole to TR infrastructure**

NFP shall lay their cable using the existing infrastructure to connect their network to the TR. Before NFP can start laying any cable, necessary approval and/or permit to work from JMB, MC, or local authority shall be obtained.

NFP shall plan the appropriate cable size and capacity to optimise the infrastructure to cater for existing and future demand. All records of duct usage shall be shared with JMB or MC. The cables shall be properly tagged at the TR, common access manhole, and intermediate manhole, if any.

JMB or MC may allocate and assign the underground duct used by every NFP and construct additional ducts if the existing ducts are insufficient.

**7.2.3 Segment C: Telecommunication Room (TR)**

Segment C covers the requirements for TR as illustrated in Figure 11.

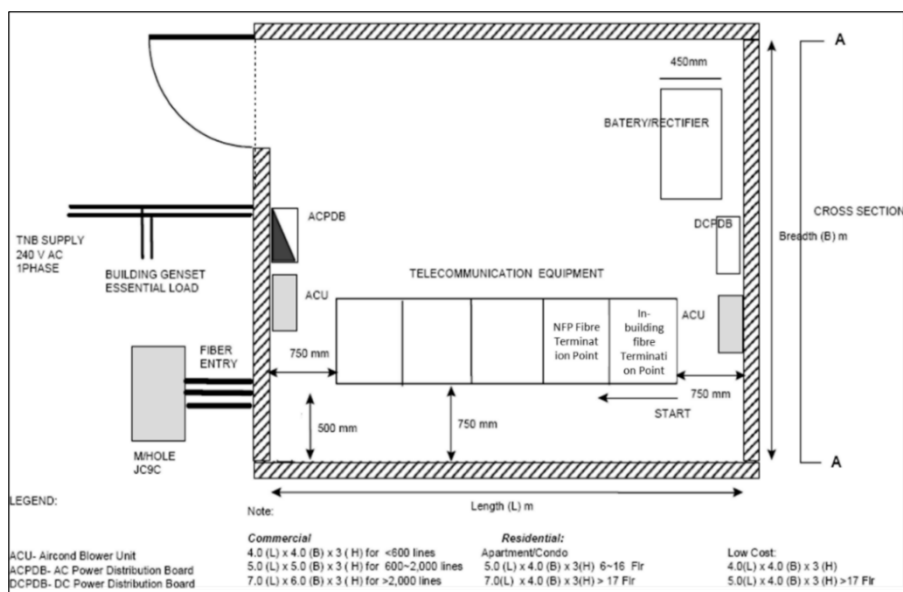

**Figure 11. Telecommunications room space arrangement**

## **MCMC MTSFB TC G055:2025**

There are 2 main termination points inside the TR as follows:

- a) NFP fibre termination point; and
- b) in-building fibre termination point.

JMB or MC shall allocate and assign the space for the termination points for each NFP. Refer to Figure 12 for the layout of the main termination points inside the TR. If there is insufficient space for additional equipment inside the TR, the NFP should make necessary arrangements with JMB or MC for a new space.

### **Figure 12. Layout of main termination points in the telecommunications room**

#### **7.2.3.1 Cable trunking system in the Telecommunication Room (TR)**

NFP shall provide the cable trunking system in the TR to manage and protect the fibre optic cable. It shall be installed from the entry point to the exit point of the fibre optic cable, which includes access to the termination points.

The detailed specifications for the cable trunking system are as specified in 9.2. If there is insufficient trunking space, the NFP should make necessary arrangements with JMB or MC for a new space.

#### **7.2.3.2 NFP fibre termination point**

The NFP termination point inside TR is referred to as NFP's Fibre Termination Box (FTB). A standard 19-inch rack is normally used for cables with high capacity. However, wall-mounted FTB may be used for cables with 128-core and below.

The fibre termination point shall be labelled and tagged as shown in Figure 13.

**Figure 13. Wall mounted FTB**

A standard 19-inch rack shall be labelled and tagged as shown in Figure 14.

**Figure 14. Standard 19-inch rack**

JMB or MC and NFP shall discuss the arrangement of FTB to ensure the space is optimised. All NFP's cables shall be terminated at the FTB. An optical splitter may also be used inside the FTB.

**7.2.3.3 In-building fibre termination point**

The in-building termination point inside TR is referred to as the in-building FTB. A standard 19-inch rack is recommended, as shown in Figure 15. The FTB shall be prepared together with vertical cabling as specified in 7.2.4. Its capacity shall be able to cover the termination of all premises.

**Figure 15. In-building FTB**

**7.2.4 Segment D: Vertical infrastructure and cabling**

Segment D refers to the requirements of vertical infrastructure and cabling connecting the in-building FTB to the floor FTB, as shown in Figure 16. The detailed specifications for the cable trunking system are specified in item 9.2.

**Figure 16. Vertical infrastructure and cabling**

**7.2.4.1 Vertical trunking**

Vertical trunking, either closed or open metal trunking, shall be used to lay fibre cable.

#### 7.2.4.2 Construction of new trunking

If existing trunking is not available or fully occupied, closed or open metal trunking shall be constructed. Wall plugs with screws shall be used to install the trunking.

#### 7.2.4.3 Floor hacking

An adequate floor hacking shall be executed using proper tools in case there is no space at the floor riser to pull the fibre cable. The size of the hacking hole depends on the trunking size that is planned to be installed. However, the trunking size shall not exceed 300 mm x 70 mm at one time.

All hacking works shall be made good with proper filling and fire-retardant material. There shall be no gap left upon completion of the installation work. Figure 17 shows an example of proper floor hacking.



**Figure 17. Proper floor hacking**

Before any floor hacking work starts, approval from JMB or MC must be obtained. The hacking method and the affected size must be clearly explained when applying for the approval.

#### 7.2.4.4 Vertical cabling

There are 2 vertical cabling designs based on respective demand scenarios.

##### 7.2.4.4.1 Pre-installed design

Figure 18 shows a sample of pre-installed cabling design. The capacity of the vertical cable shall be able to cover the termination of all premises. This design normally applies when the JMB or MC provides the fibre cabling.

The cabling requirement for every premises shall be as follows:

- a) minimum of 2 cores for residential premises; and
- b) minimum of 4 cores for commercial, industrial, or government building.

JMB or MC shall consult NFP should there be additional requirements for the number of cores.

## MCMC MTSFB TC G055:2025

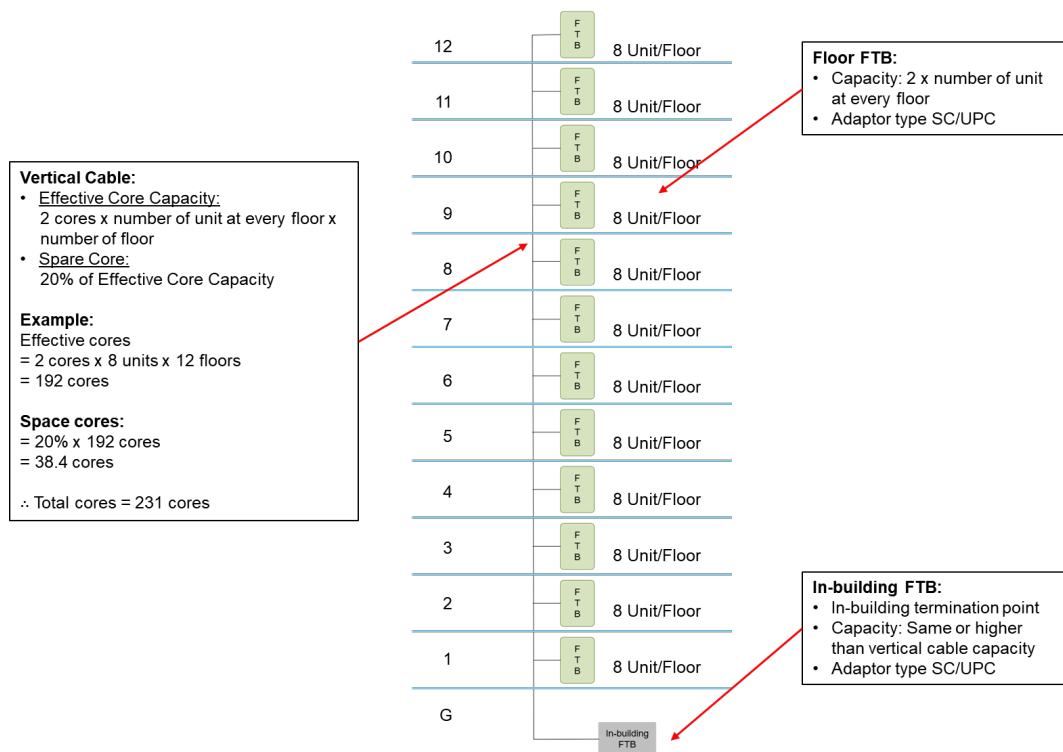

**Figure 18. Sample of pre-installed cabling design for building with 8-unit premises per floor**

### 7.4.4.2 Demand-based design

For demand-based design, the capacity of in-building FTB, vertical cable, and floor FTB depends on the forecasted demand for the building. This design normally applies for cases where NFP provides the cabling. Additional capacity may be added if the existing capacity is not enough to accommodate new demand.

There are 2 types of cabling design that can be adopted, which are:

- direct cabling; or
- using an optical splitter.

The direct cabling design involves one-to-one cabling from the in-building FTB to the floor FTB, as shown in Figure 19.

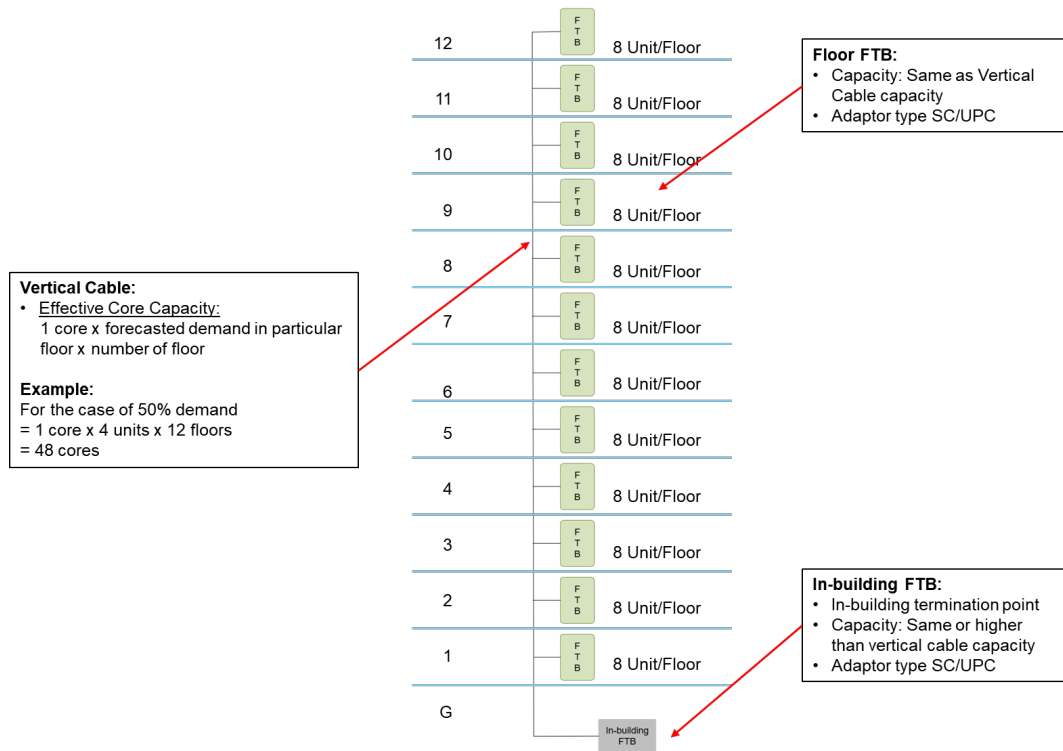
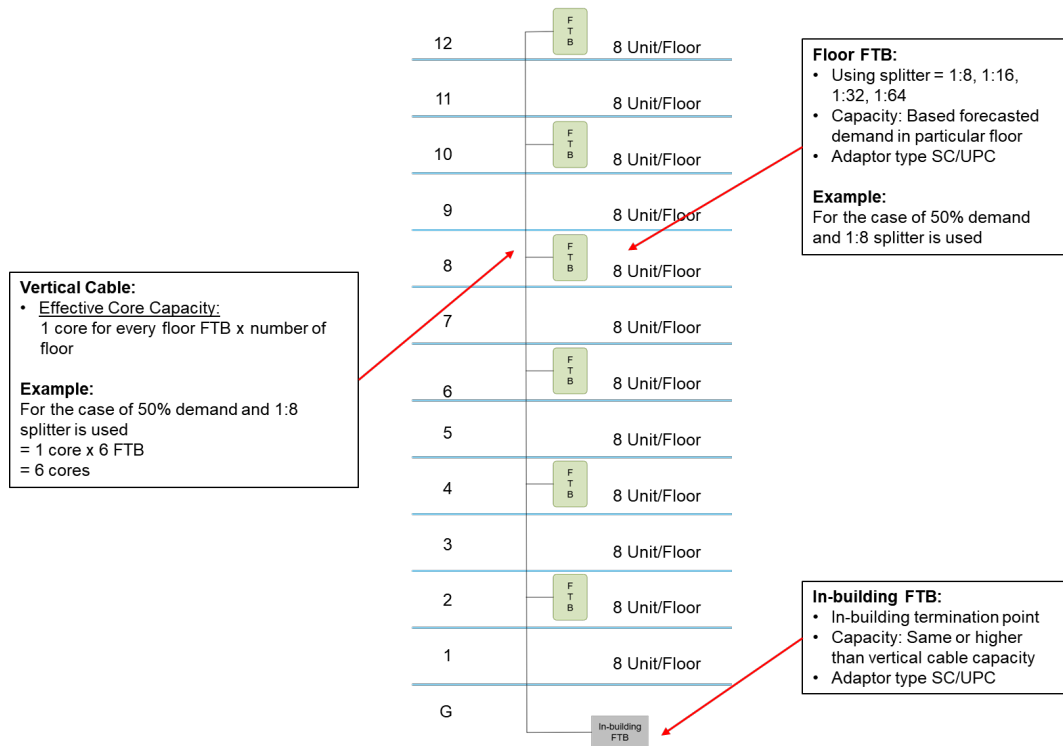

**Figure 19. Sample of demand-based direct cabling design for building with 8-unit premises per floor**

For the cabling design using an optical splitter, the fibre core from the in-building FTB will be split at the floor FTB for distribution to the premises. The design depends on overall NFP network planning and shall be mutually agreed upon between NFP and JMB or MC.

Figure 20 shows a sample optical splitter cabling design. The calculation is based on 50% demand and uses a 1:8 splitter at the floor FTB.

## MCMC MTSFB TC G055:2025



**Figure 20. Sample of demand-based using optical splitter design for building with 8-unit premises per floor**

### 7.2.4.5 Vertical cable installation

During the installation of the vertical cable, the cable shall be tied properly with a cable tie to the trunking. A proper length of cable shall be used to avoid any intermediate joint.

A tap-out technique shall be used to minimise the insertion loss at every joint. Only the related fibre core shall be cut, while the other cable cores shall remain in the cable.

#### 7.2.4.5.1 Cable installation via open trunking

Figure 21 shows a sample of vertical open trunking. For conventional indoor or outdoor cable types with pulling strength > 1,000 Nm, the cable shall be pulled using a corrugated duct or can be directly installed without any protection conduit.

For other cables with lower tensile strength, such as micro cable or drop cable, the cable shall be installed using microduct to provide protection to the cable.



**Figure 21. Vertical cable installation via open trunking**

Proper tagging, as shown in Figure 22, shall be used on every floor for easier identification. The tag shall be placed directly on the cable or protection duct.

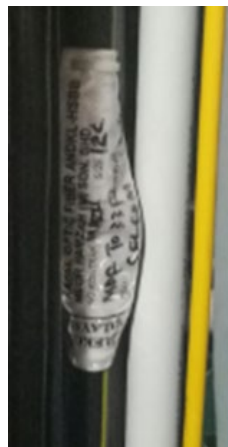

**Figure 22. Cable tagging**

#### **7.2.4.5.2 Cable installation via closed metal trunking**

All cables shall be laid without any conduit or duct inside the closed metal trunking, in order to optimise the space. The metal trunking cover shall be carefully opened before installing the cable and shall be properly closed upon the completion of the cable installation works.

A proper tool shall be used to open the metal trunking cover. Do not use force to open the metal trunking to avoid damaging the metal trunking and its cover.

#### **7.2.4.6 Inter-building connection**

An inter-building connection connects two or more buildings to a single TR that is connected to the NFP network. The readiness of the infrastructure for inter-building connection shall be agreed upon between JMB or MC and NFP.

## MCMC MTSFB TC G055:2025

In-building cabling shall be laid via underground ducting, as explained in 7.2.2. The cabling's capacity shall follow the same requirements as in 7.2.4.4. The sample of the inter-building connection is shown in Figure 23.

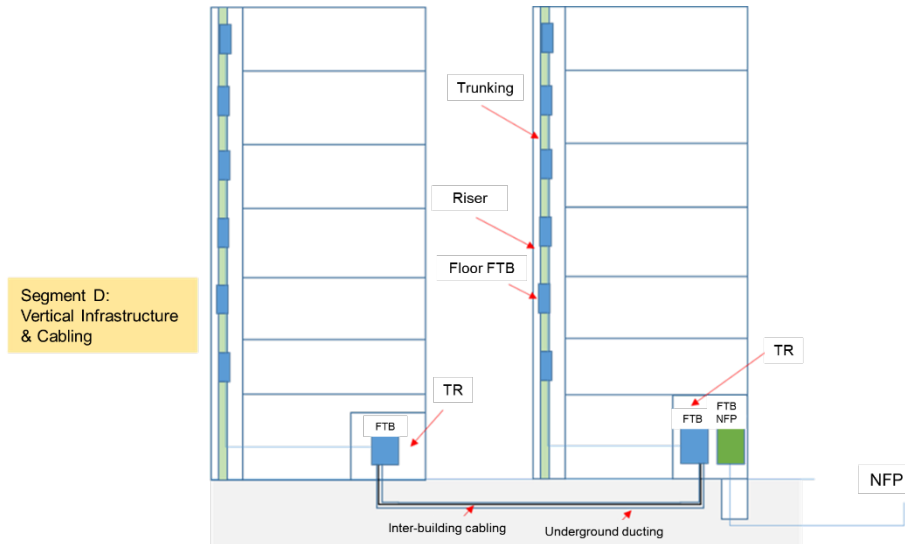

**Figure 23. Inter-building connection**

### 7.2.5 Segment E: Horizontal infrastructure and cabling

Segment E refers to the requirements of horizontal infrastructure and cabling connecting the floor FTB to individual premises, as shown in Figure 24.

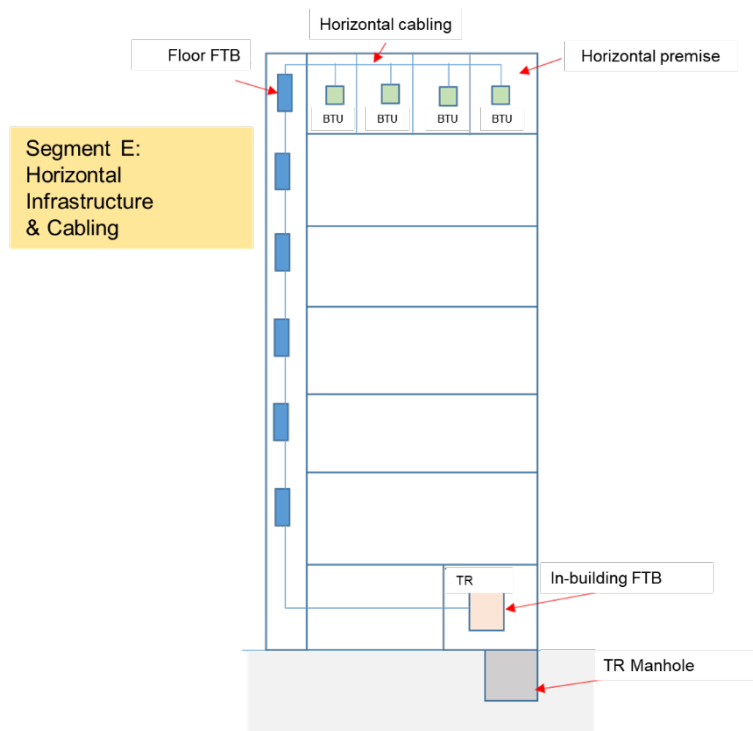

**Figure 24. Horizontal infrastructure**

### 7.2.5.1 Pre-installed trunking with cabling

Pre-installed horizontal trunking and cabling are recommended for the high-demand service building category. It is also recommended that the trunking and cabling be provided by the JMB or MC. The pre-installed horizontal trunking and cabling are shown in Figure 25.

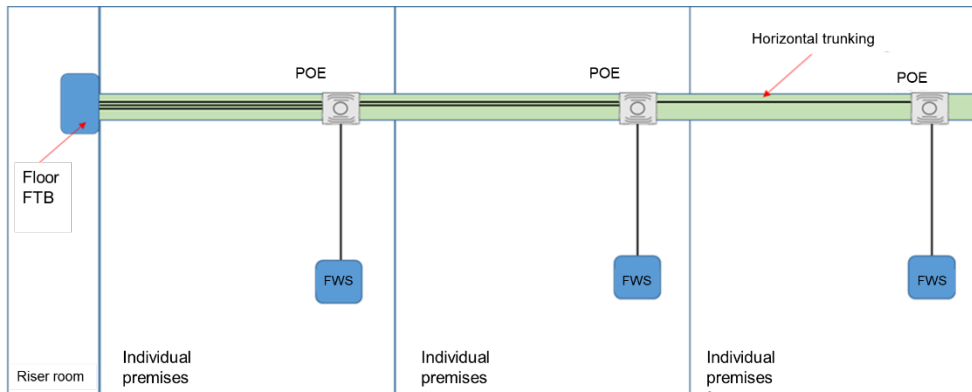

Figure 25. Horizontal trunking with pre-installed cabling

#### 7.2.5.1.1 Horizontal cabling

Horizontal cabling refers to the floor distribution cabling between the floor FTB and Fibre Wall Socket (FWS) of the individual premises, with the following capacity:

- a) residential type, a minimum of 2 cores for each premises; and
- b) commercial or business type, a minimum of 4 cores for each premises.

10 % extra cores are recommended to be prepared for a spare core. JMB or MC is recommended to consult with NFP for the appropriate capacity planning.

Horizontal cabling shall be pre-terminated at FWS of individual premises using Standard Connector/Ultra Polished Connector (SC/UPC) or Standard Connector/Angle Polished Connector (SC/APC) type. At the floor FTB side, the connection type depends on the following scenarios:

- a) for pre-installed vertical cabling design, the horizontal cables from individual premises can be terminated using direct splicing or using SC/UPC or SC/APC type; or
- b) for demand-based vertical cabling design (not full capacity), the horizontal cables from individual premises can be terminated at an empty adaptor or properly left hanging inside the floor FTB using SC/UPC or SC/APC type. Every cable shall be tagged and labelled properly with the unit number of the premises.

#### 7.2.5.1.2 Horizontal trunking

The horizontal trunking can be installed using the following methods:

- a) trunking installed on exposed wall;
- b) concealed trunking inside the wall;
- c) concealed trunking under the floor; or

## MCMC MTSFB TC G055:2025

d) trunking through the ceiling.

The size of the trunking depends on the capacity and size of the cable. The trunking shall be made of Polyvinyl Chloride (PVC) or higher-grade material. The trunking specifications are shown in Table 3.

**Table 3. Trunking specifications**

Type of trunking	Unit per floor	Specifications
Conduit	8 and below	Minimum of 25 mm diameter
	More than 8	Minimum of 50 mm diameter
Closed trunking	8 and below	Minimum of 25 mm (W) x 25 mm (H)
	More than 8	Minimum of 50 mm (W) x 50 mm (H)

Horizontal trunking shall be installed at a maximum of 3 m height from the floor and below the ceiling level, with easy access for the installation on an exposed wall.

### 7.2.5.2 Pre-installed trunking with cabling up to Point of Entry (POE)

Pre-installed horizontal trunking with cabling up to the Point of Entry (POE), as shown in Figure 26, is recommended for high-demand buildings and will be provided by the NFP. The in-premises cabling will be installed as and when a customer subscribes to the service from the NFP.

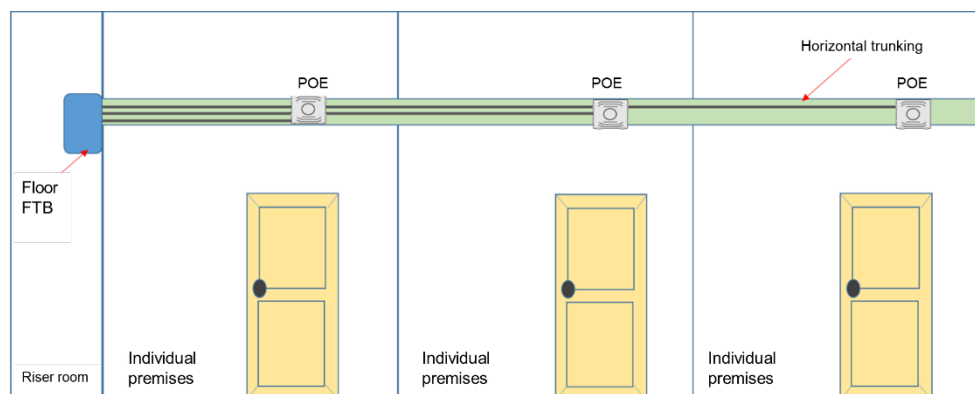

**Figure 26. Horizontal trunking with cabling up to POE design**

Pre-installed trunking will only cover the common area portion without entering the individual premises. POE shall be prepared in front of every premises for the horizontal cable to exit and be ready to enter the individual premises later.

#### 7.2.5.2.1 Horizontal cable

Horizontal cable refers to the floor distribution cabling between the floor FTB to every POE of individual premises with the same capacity as explained in 7.2.5.1.1. Horizontal cable shall be pre-terminated at the POE of individual premises using SC/UPC or SC/APC connector or left as bare fibre. At the floor FTB side, the requirement is the same as explained in 7.2.5.1.1. Bend-insensitive drop cable or indoor cable type is highly recommended for easy identification, installation, handling, and maintenance.

#### 7.2.5.2.2 Horizontal trunking

The horizontal trunking specification and requirements are as explained in 7.2.5.1.2.

**7.2.5.2.3 Point of Entry (POE) with pre-terminated fibre**

POE is recommended to be used to store the pre-installed fibre core, as shown in Figure 27. The fibre core may be left either as a bare fibre or terminated with SC/UPC or SC/APC connector, as shown in Figures 28 and 29.

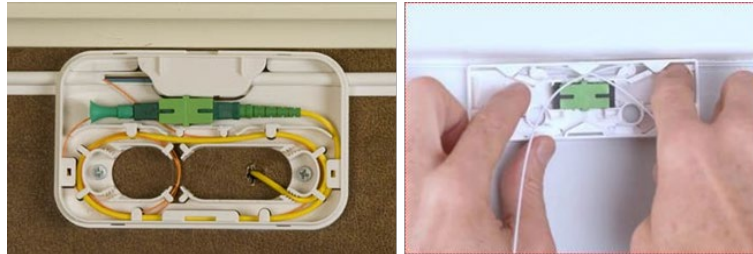

**Figure 27. Sample of POE with fibre**

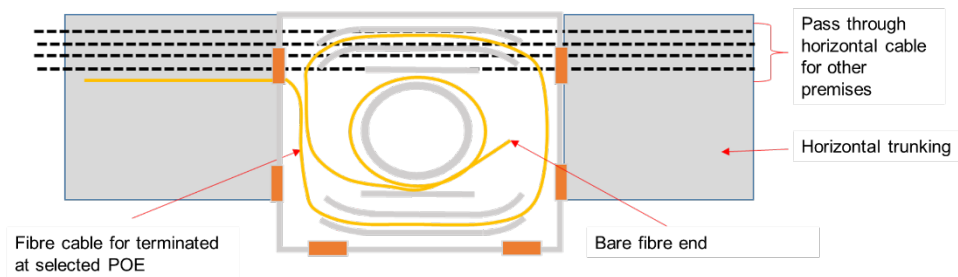

**Figure 28. POE with bare fibre**

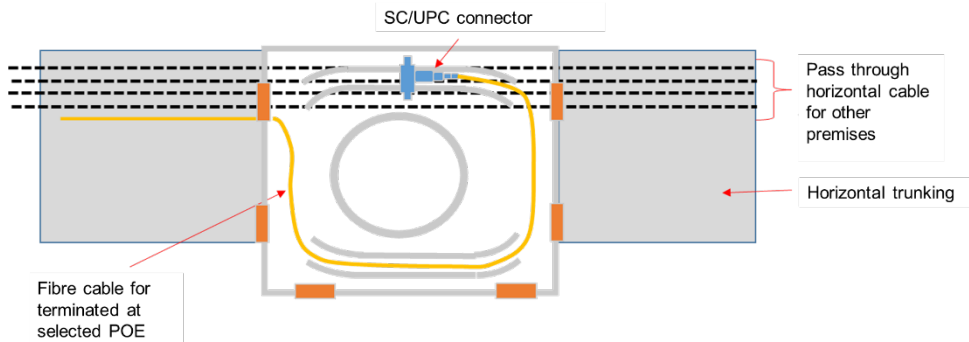

**Figure 29. POE with SC/UPC or SC/APC connector**

POE shall be installed and meet the requirements as follows:

- a) located indoors of the building and same level of horizontal trunking or lower, with a maximum height of 3 m;
- b) practically and technically accessible for the installation of cable into the premises later;
- c) not disturbing the resident or public;
- d) safe and in a protected environment; and
- e) using suitable material and specification for indoor.

## MCMC MTSFB TC G055:2025

It is highly recommended to get the consent from the premises owner on the suitability of the POE location before the installation.

### 7.2.5.3 Pre-installed trunking without cabling

Pre-installed horizontal trunking without cabling, as shown in Figure 30, is recommended for low-demand service buildings and is to be provided by the JMB or MC. The cabling will be installed by NFP, JMB, or MC when the premises owner subscribes to the service. The NFP should make necessary arrangements with JMB or MC to access existing or install new horizontal trunking.

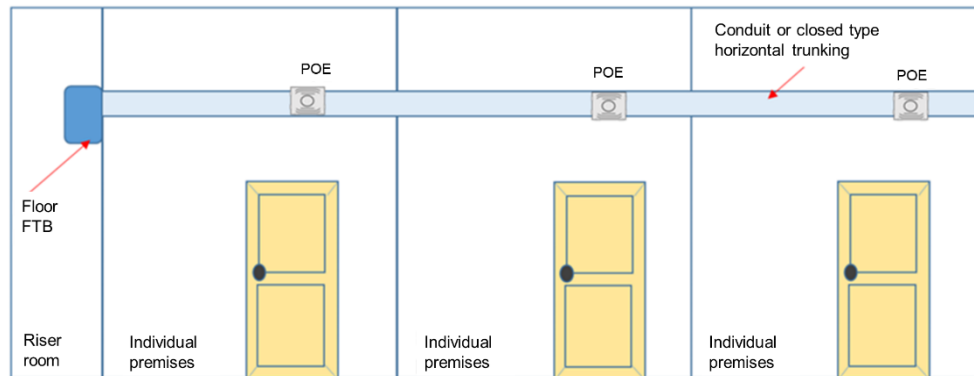

**Figure 30. Conduit or closed type horizontal trunking without cabling**

Pre-installed trunking will only cover the common area portion without entering individual premises. POE shall be installed in front of every premises for horizontal cable to exit and enter the individual premises later.

#### 7.2.5.3.1 Horizontal trunking

The installation shall be as explained in 7.2.5.2.2. In the case of conduit type, a draw rope shall be prepared with proper premises unit number tagging at the FTB side. The other end of the draw rope shall be stored properly at the POE of the related premises.

#### 7.2.5.3.2 Point of Entry (POE)

The installation shall be as in 7.2.5.2.3 without the fibre installed. For conduit type, a draw rope shall be installed, and for closed trunking type, it shall be left empty.

### 7.2.5.4 Demand-based horizontal cabling

Demand-based horizontal cabling is recommended for low-demand service buildings. The cabling shall be provided by NFP when a service is subscribed.

#### 7.2.5.4.1 Cable installation using existing trunking

Horizontal cabling shall be installed using existing trunking if it is available.

The installation method depends on the trunking type. Draw rope shall be used for cabling installation through conduit type as shown in Figure 31. Rodding process shall be performed in case the draw rope is not available or broken.

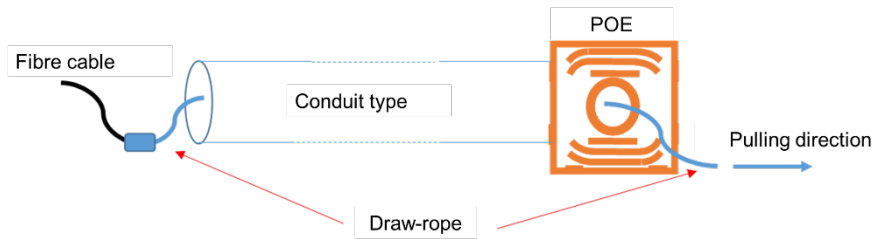

**Figure 31. Pulling cable through conduit type**

Cabling may be installed directly without any protection duct for open trunking type as shown in Figure 32.

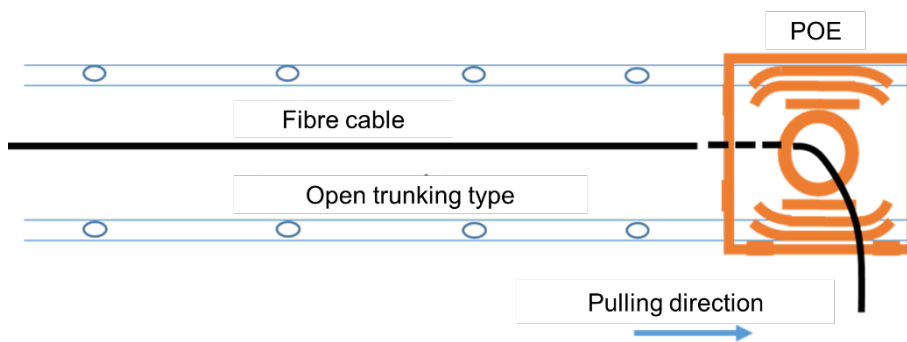

**Figure 32. Pulling cable through open trunking type**

**7.2.5.4.2 Cable installation without existing trunking**

The installation methods depend on the agreement with JMB or MC. Below are some of the methods that can be used:

- a) Clip on the wall (see Figure 33)

This method is suitable for cases where a drop cable or a small indoor cable is used. A wall clip or suitable adhesive tape can be used to fix the cable to the wall surface.

The colour of the cable is recommended to follow the wall colour. The cable shall be installed at a maximum height of 3 m from the floor and below the ceiling level, with easy access.

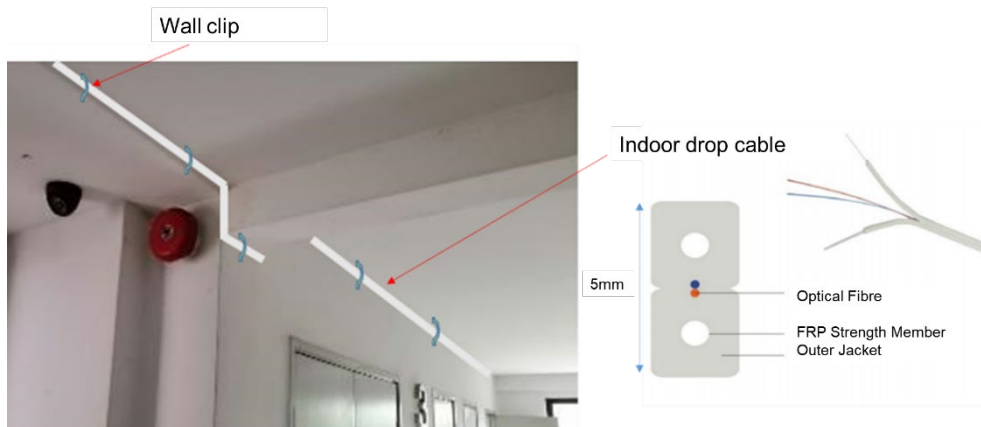
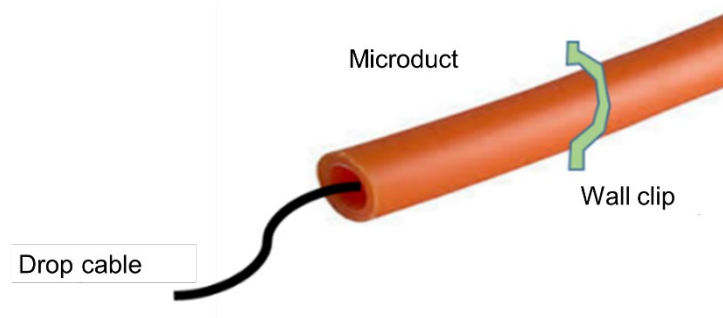

**Figure 33. Clip on the wall method**

## MCMC MTSFB TC G055:2025

- b) Clip on the wall with microduct (see Figure 34)

The colour of the microduct is recommended to follow the wall colour. This method is suitable for cases where the horizontal cable is exposed to the outdoor environment.



**Figure 34. Clip on the wall with microduct**

- c) Over the ceiling

Horizontal cable may be installed over the ceiling in case the ceiling is not too high. A proper ceiling entrance and exit hole (ceiling pit) shall be made available for this method.

The cable shall be protected using a microduct.

### 7.2.6 Segment F: Internal fibre cabling

Internal fibre cabling refers to the cabling from POE to FWS inside the individual premise, as shown in Figure 35.

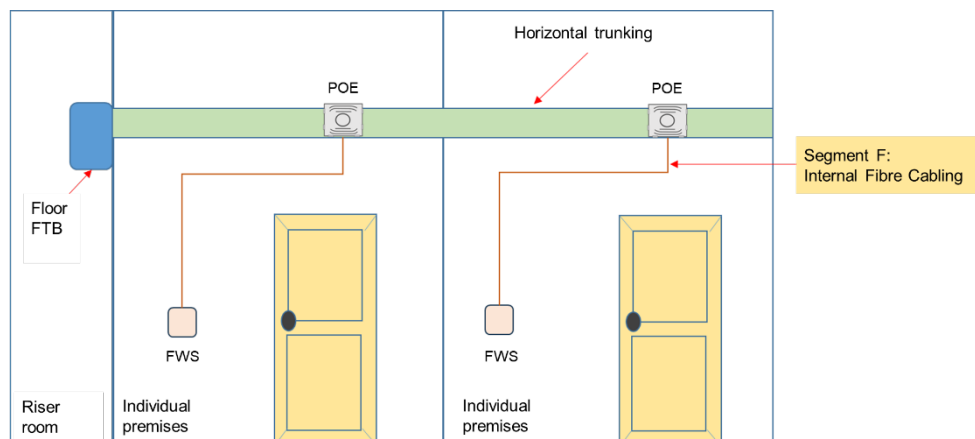

**Figure 35. Internal fibre cabling**

For demand-based design, internal fibre cabling shall be installed according to 7.2.5.4. For pre-installed design, the installation shall be according to MCMC MTSFB TC G024.

For internal fibre cabling, indoor drop cable is recommended. Where FWS is installed, the SC/UPC or SC/APC connector type shall be used, as shown in Figure 36.

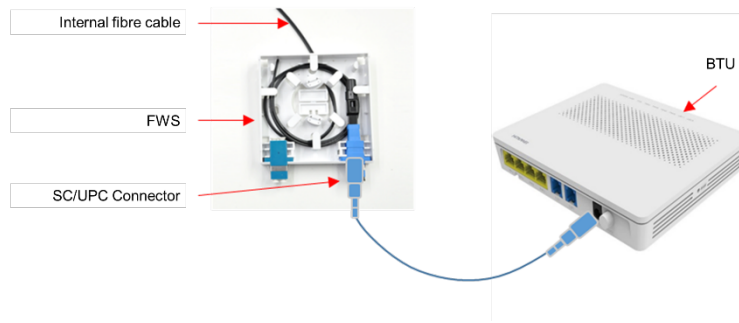

**Figure 36. Internal fibre cabling with FWS installed**

For commercial or office buildings, internal fibre cabling shall be terminated inside the server, equipment, or Private Automatic Branch Exchange (PABX) room as shown in Figure 37.

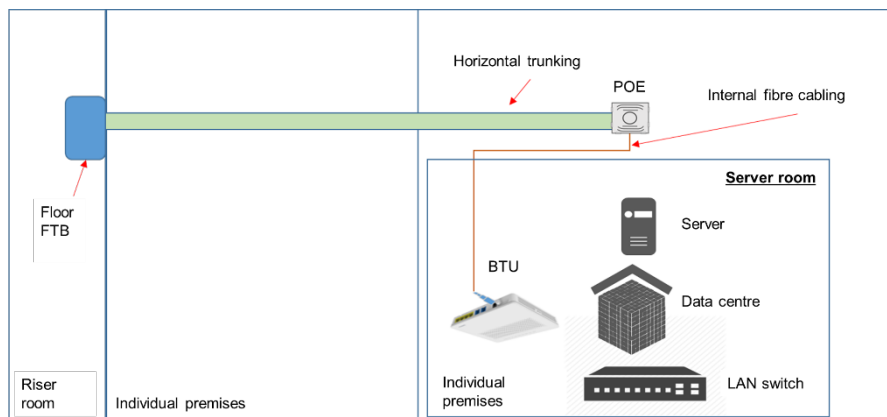
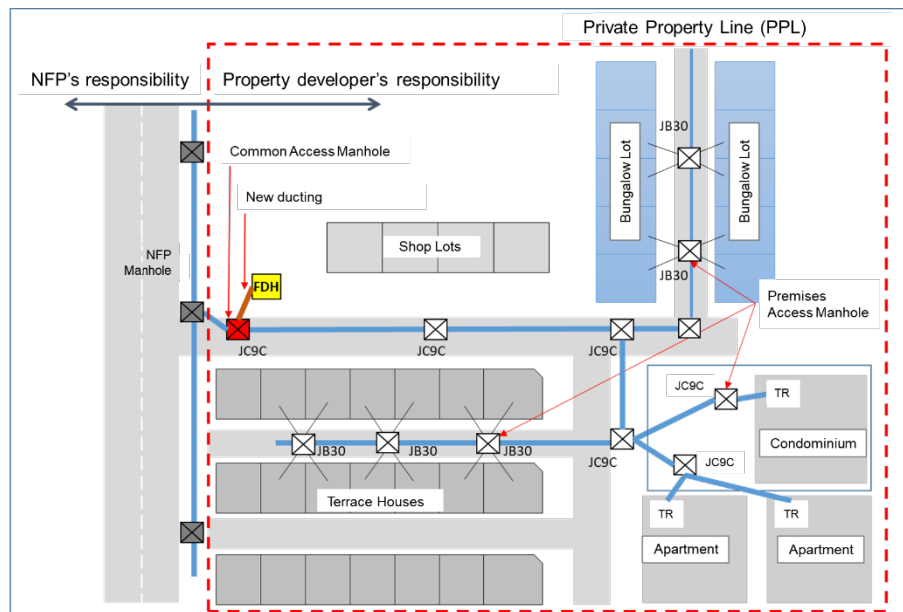

**Figure 37. Internal fibre cabling for commercial or office building**

### 7.3 Infrastructure and cabling requirements for strata development area

Infrastructure and cabling requirements for a property converted from an individual title to a strata title are separated at the PPL. All infrastructure inside the PPL is under JMB or MC responsibilities. The NFP is required to build a new Fibre Distribution House (FDH) and new ducting connecting from the FDH to the existing external infrastructure, as shown in Figure 38. The detailed specifications are described in MCMC MTSFB TC G024.

## MCMC MTSFB TC G055:2025



**Figure 38. Infrastructure and cabling requirements for strata property**

### 7.4 Permission to access the infrastructure

The NFP shall obtain permission to use any infrastructure inside the premises owner boundary or PPL from the related infrastructure owner. The NFP shall ensure existing infrastructures and network services are not damaged or disrupted when accessing the infrastructure.

The NFP shall notify the existing NFP to use any external infrastructures to ensure existing network services are not disrupted when accessing the infrastructure.

The NFP is fully responsible for any damage or service disruption during the works.

## 8. External infrastructure requirements

The detailed specifications for external infrastructure requirements are described in MCMC MTSFB TC G024 and MCMC MTSFB TC G025.

## 9. Cabling specifications

### 9.1 Cable

The specifications shall be according to the requirements specified in MCMC MTSFB TC G024.

### 9.2 Cable trunking

There are 2 types of cable trunking that can be used in TR, or as vertical trunking, as follows:

- a) open trunking; and
- b) closed trunking.

**9.2.1 Open trunking**

There are 2 types of open trunking system as follows:

- a) metal cable ladder; and
- b) metal cable tray.

Refer to Figures 39 and 40 for the cable trunking types.

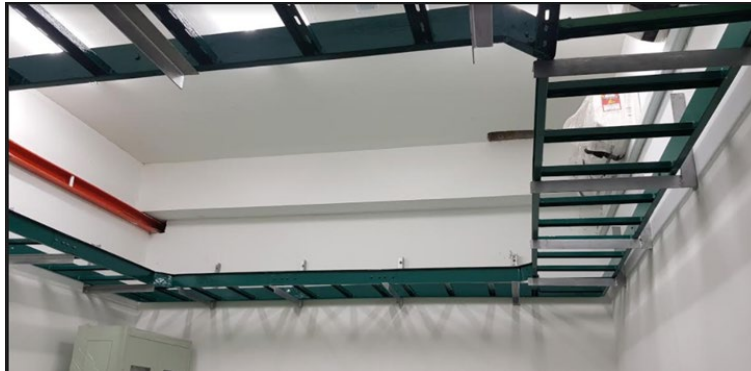

**Figure 39. Sample of metal cable ladder**



**Figure 40. Sample of metal cable tray**

The open trunking used in TR shall be either a mild steel type or a higher grade, and the recommended colour is green, as shown in Figure 39.

The specifications for open trunking are tabulated in Table 4.

**Table 4. Open trunking specifications**

Parameter	Specifications
Width	200 mm - 300 mm
Height	10 mm - 50 mm
Thickness	1.5 mm - 2.0 mm
Material	Mild Steel SS 304

**9.2.2 Closed trunking**

The closed trunking shall be either metal or PVC and the recommended colour is green as shown in Figure 41. The thickness of the trunking shall be 2 mm and the minimum size shall be 100 mm x 50 mm.

## MCMC MTSFB TC G055:2025



**Figure 41. Closed trunking type**

### **9.3 Duct and micro duct**

The specifications shall be according to the requirements specified in MCMC MTSFB TC G024.

### **9.4 Fibre Termination Box (FTB)**

The specifications shall be according to the requirements specified in MCMC MTSFB TC G024.

### **9.5 Fibre Wall Socket (FWS)**

The specifications shall be according to the requirements specified in MCMC MTSFB TC G024.

### **9.6 Point of entry (POE)**

The POE shall be suitable for attachment to the inside or outside wall of an individual premise.

The material shall be able to protect the component against harsh, high-heat heat and humid environments.

The POE shall be designed and conformed to IP44 of IEC 60529 or higher for indoor application and IP54 of IEC 60529.

The material of the high-density and medium-density POE shall conform to ISO 2081 or other recognised standards. All POE shall be made of fire-retardant material.

All the plastic material shall have a rating of V-1 or higher as determined by Underwriters Laboratories' UL 94 standards.

The maximum overall dimension shall be 203 mm (H) x 127 mm (W) x 38 mm (D).

The POE design shall have a suitable splice tray and cable management area to provide for a minimum bending radius and for storage of ruggedised splitter pigtails.

The POE shall have pre-assembled plates with SC/UPC or SC/APC type of adaptor coupling for fibre patching if required. It shall be designed with 2 physically separated compartments to isolate the incoming cable and outgoing cable.

All cable entries shall be provided with rubber grommets to protect the cable and prevent pest and dirt entry.

### **9.7 Quality of the materials**

The specifications shall be according to the requirements specified in MCMC MTSFB TC G024.

**10. Labelling and tagging**

The specifications for labelling and tagging shall be in accordance with MCMC MTSFB TC G024.

**11. Testing and commissioning**

The specifications and test methods for testing and commissioning shall be in accordance with MCMC MTSFB TC G024.

**12. Safety and precautions**

The specifications for safety and precaution requirements shall be in accordance with MCMC MTSFB TC G024.

**Normative references**

*Communications and Multimedia Act 1998 (Act 588)*

*Strata Management Act 2013 (Act 757)*

*Strata Titles Act 1985 (Act 318)*

MCMC MTSFB TC G024 *Fixed Network Facilities - In-Building and External*

MCMC MTSFB TC G025-1 *Basic Civil Works - Part 1: General Requirements*

MCMC MTSFB TC G025-2 *Basic Civil Works - Part 2: Open Trench*

MCMC MTSFB TC G025-3 *Basic Civil Works - Part 3: Micro Trench*

MCMC MTSFB TC G025-4 *Basic Civil Works - Part 4: Horizontal Directional Drilling*

MCMC MTSFB TC G025-5 *Basic Civil Works - Part 5: Last Mile Fixed Network Telecommunications Pole*

IEC 60529 *Degrees of protection provided by enclosures (IP Code)*

IEC 60825-1 *Safety of laser products - Part 1: Equipment classification and requirements*

ISO 2081 *Metallic and other inorganic coatings - Electroplated coatings of zinc with supplementary treatments on iron or steel*

GR-771 *Generic Requirements for Fiber Optic Splice Closure*

UL 94 V *Tests for Flammability of Plastic Materials for Parts in Devices and Appliances*

**Annex B**  
(informative)

**Abbreviations**

BTU	Broadband Termination Unit
DP	Distribution Point
FDH	Fibre Distribution House
FDP	Fiber Distribution Point
FTB	Fibre Termination Box
FWS	Fibre Wall Socket
HDD	Horizontal Directional Drilling
IP	Internet Protocols
IPTV	Internet Protocol Television
JMB	Joint Management Body
MC	Management Corporation
MDU	Multi-Dwelling Unit
NFP	Network Facilities Provider
PABX	Private Automatic Branch Exchange
P2MP	Point-to-Multipoint Fibre
P2P	Point-To-Point
POE	Point of Entry
PPL	Private Property Line
PVC	Polyvinyl Chloride
SC/APC	Standard Connector/Angle Polished Connector
SC/UPC	Standard Connector/Ultra Polished Connector
SDU	Single Dwelling Unit
TR	Telecommunications Room
VoIP	Voice over Internet Protocol

# **MCMC MTSFB TC G055:2025**

## **Acknowledgements**

### **Members of the Fixed Network Facilities Working Group**

#### **Working Group Leaders**

Ts Amir Subhi Wan Omar (Chair)	TM Technology Services Sdn Bhd
Mr Zulkefli Zabri (Vice chair)	Maxis Broadband Sdn Bhd
Ir Dr Anas Abdul Latiff (Secretary)	Universiti Teknikal Malaysia Melaka

#### **Drafting Committee Members**

Mr Mohamed Azli Ab Jalil (Draft lead)	Maxis Broadband Sdn Bhd
Mr Muhaimin Mat Salleh (Secretariat)	Malaysian Technical Standards Forum Bhd
Mr Mohd Mokhtar Daud	Malaysia Digital Economy Corporation Sdn Bhd
Mr Eami Yusry Mohd Yusof	Maxis Broadband Sdn Bhd
Mr Zulkefli Zabri	Maxis Broadband Sdn Bhd
Mr Nazar Mohd Nong	TM Technology Services Sdn Bhd
Ts Sufian Sulaiman	TM Technology Services Sdn Bhd
Mr Salleh Husin	TT Dotcom Sdn Bhd
Prof Ir Dr Badrul Hisham Ahmad	Universiti Teknikal Malaysia Melaka

#### **Contributors**

YM Raja Zahiruddin Raja Muda	CelcomDigi Berhad
Mr Peter Barry Macaulay	CelcomDigi Berhad
Mr Mohd Kasyful Azim Ab Rahman	Maxis Broadband Sdn Bhd
Mr Mohd Nazim Mahmud	Maxis Broadband Sdn Bhd
Ms Ku Hasniza Ku Hashim	Malaysia Digital Economy Corporation Sdn Bhd
Mr Leong Woon Min	Redsun Engineering Sdn Bhd
Ms Norhanisah Mohd Basri	SIRIM Berhad
Ts Mohd Zulfadzli Abu Seman	SIRIM Berhad
Mr Yousri Taibin	Terengganu Telecommunications Sdn Bhd
Ms Erliz Rizuan	TM Technology Services Sdn Bhd
Ms Fatimah Salwani Ramli	TM Technology Services Sdn Bhd
Ms Hana Afita Shahar	TM Technology Services Sdn Bhd
Mr Mohd Fahmi Hassim	TM Technology Services Sdn Bhd
Mr Mohd Fuad Turiman	TM Technology Services Sdn Bhd
Mr Mohd Nizam Osman	TM Technology Services Sdn Bhd
Mr Mohd Saiful Azim Mohd Safian	TM Technology Services Sdn Bhd
Mr Mohd Saiful Shapiai	TM Technology Services Sdn Bhd
Mr Mohd Syahrir Ribuan	TM Technology Services Sdn Bhd
Mr Nor Hafiz Mohd Razali	TT Dotcom Sdn Bhd
Mr Md Amir Hasan	U Mobile Sdn Bhd

**MCMC MTSFB TC G055:2025**

Dr Muhammad Yusof Mohd Noor

*Mr Syahmi Ghazali*

*Mr Norulazwan Nordin*

*Ms Nor Sahaniza*

*PMgr Mohd Razik Haji Mohamed Shakif*

*Mr Mohd Khalid Zakaria*

Universiti Teknologi Malaysia

*Allo Technology Sdn Bhd*

*Jabatan Kerja Raya Malaysia*

*Majlis Bandaraya Seberang Perai*

*Malaysian Institute of Property and Facility Managers*

*XMT Technologies Sdn Bhd*