

MCMC MTSFB TC G011:2023

# TECHNICAL CODE

## RADIOCOMMUNICATIONS NETWORK FACILITIES - IN-BUILDING COVERAGE SYSTEM (FIRST REVISION)

Developed by



Registered by



Registered date: 31 October 2023

© Copyright 2023

## **MCMC MTSFB TC G011:2023**

### **Development of technical codes**

The Communications and Multimedia Act 1998 (Laws of Malaysia Act 588) ('the Act') provides for a Technical Standards Forum designated under section 184 of the Act or the Malaysian Communications and Multimedia Commission ('the Commission') to prepare a technical code. The technical code prepared pursuant to section 185 of the Act shall consist of, at least, the requirements for network interoperability and the promotion of safety of network facilities.

Section 96 of the Act also provides for the Commission to determine a technical code in accordance with section 55 of the Act if the technical code is not developed under an applicable provision of the Act and it is unlikely to be developed by the Technical Standards Forum within a reasonable time.

In exercise of the power conferred by section 184 of the Act, the Commission has designated the Malaysian Technical Standards Forum Bhd ('MTSFB') as a Technical Standards Forum which is obligated, among others, to prepare the technical code under section 185 of the Act.

A technical code prepared in accordance with section 185 shall not be effective until it is registered by the Commission pursuant to section 95 of the Act.

For further information on the technical code, please contact:

#### **Malaysian Communications and Multimedia Commission (MCMC)**

MCMC Tower 1  
Jalan Impact  
Cyber 6  
63000 Cyberjaya  
Selangor Darul Ehsan  
MALAYSIA

Tel: +60 3 8688 8000  
Fax: +60 3 8688 1000  
<http://www.mcmc.gov.my>

OR

#### **Malaysian Technical Standards Forum Bhd (MTSFB)**

MCMC Tower 2  
Jalan Impact  
Cyber 6  
63000 Cyberjaya  
Selangor Darul Ehsan  
MALAYSIA

Tel: +60 3 8680 9950  
Fax: +60 3 8680 9940  
<http://www.mtsfb.org.my>

**Contents**

	<b>Page</b>
Committee representation .....	ii
Foreword .....	iii
0. Introduction .....	1
1. Scope.....	1
2. Normative references .....	1
3. Abbreviations .....	2
4. Civil, Mechanical and Electrical (CME) requirement .....	2
4.1 Equipment enclosures.....	2
4.2 Floor loading.....	5
4.3 Riser size.....	5
4.4 Cable ladders and cable supports.....	6
4.5 Fire extinguisher.....	6
4.6 Security facility .....	6
4.7 Climate control system.....	6
4.8 Power supply system .....	7
4.9 Global Positioning System (GPS) .....	11
4.10 Transmission backhaul requirement .....	11
5. In-Building Coverage (IBC) Distributed Antenna System (DAS) requirement.....	13
5.1 Types of IBC DAS for mobile services .....	14
5.2 Wireless Fidelity (WiFi) installation .....	26
5.3 Key Performance Index (KPI) .....	27
5.2 Capacity requirement.....	33
6. Quality of Service (QoS) and Service Level Agreement (SLA) .....	33
6.1 Mandatory standards imposed by MCMC.....	33
6.2 Service Level Agreement (SLA).....	33
7. Responsibility matrix.....	34
Annex A Abbreviation.....	36
Annex B Combiner Specification.....	38
Annex C WiFi cabling configurations .....	39
Annex D Quality of Experience (QoE).....	43
Annex E Service Level Agreement (SLA) .....	46
Annex F Service level requirements .....	48
Bibliography.....	50

## **MCMC MTSFB TC G011:2023**

### **Committee representation**

The technical code was developed by Radiocommunications Network Facilities (Internal) Sub Working Group under the Radio Network Facilities Working Group of the Malaysian Technical Standards Forum Bhd (MTSFB), which consists of representatives from the following organisations:

Celcom Axiata Berhad

Digi Telecommunications Sdn Bhd

Digital Nasional Berhad

edotco Malaysia Sdn Bhd

International Islamic University Malaysia

Maxis Broadband Sdn Bhd

Telekom Malaysia Berhad

U Mobile Sdn Bhd

Webe Digital Sdn Bhd

YTL Communications Sdn Bhd

## **Foreword**

This technical code for the Radiocommunications Network Facilities - In-Building Coverage System (First Revision) ('this Technical Code') was developed pursuant to Section 185 of the Communications and Multimedia Act 1998 (Laws of Malaysia Act 588) by the Malaysian Technical Standards Forum Bhd (MTSFB) via its Radiocommunications Network Facilities (Internal) Sub Working Group under the Radio Network Facilities Working Group.

This Technical Code shall replace the MCMC MTSFB TC G011:2017, *Radiocommunications Network Facilities - In-Building*.

Major modification in this revision is the update of the Key Performance Index (KPI) and addition on Fifth Generation (5G) specifications which are in line with the current mobile technology in Malaysia.

This Technical Code shall continue to be valid and effective from the date of its registration until it is replaced or revoked.

(THIS PAGE IS INTENTIONALLY LEFT BLANK)

## RADIOCOMMUNICATIONS NETWORK FACILITIES - IN-BUILDING COVERAGE SYSTEM

### 0. Introduction

In the context of meeting the needs of telecommunication (in-building) users, this Technical Code addresses the minimum requirements necessary for the internal radiocommunications network facilities. It formulates a general requirement related to the necessary Civil, Mechanical and Electrical (CME) works. It also serves to provide information on the various models available for different types of building installations and acts as a reference document for the telecommunication asset owners, building owners, relevant authorities and any other stake holders.

This Technical Code also promotes the use of standardised designs and materials to leverage on economy of scale as well as the reuse of current available infrastructure. Apart from that, this Technical Code looks to establish industry practices that meet international standards and comply with guidelines issued by the relevant authorities.

### 1. Scope

This Technical Code specifies requirements for in-building coverage systems for mobile telecommunication facilities and design which is focused on CME facilities and radio infrastructure design with the purpose to harmonise the cabling design, antenna systems and other common infrastructure design of multi technologies and operators sharing.

The requirements are divided into 4 areas as follows.

a) CME

Requirements for in-building wireless system, backhaul, Global Positioning System (GPS), mobile and Wireless Fidelity (WiFi).

b) In-Building Coverage (IBC) Distributed Antenna System (DAS)

Requirements for Radio Frequency (RF) material, RF distribution design and RF distribution Key Performance Index (KPI).

c) Quality of Service (QoS) and Service Level Agreement (SLA)

Requirements on QoS and SLA for an in-building wireless system.

d) Responsibility matrix

Responsibility party to provide in-building wireless system.

### 2. Normative references

The following normative references are indispensable for the application of this Technical Code. For dated references, only the edition cited applies. For undated references, the latest edition of the normative references (including any amendments) applies.

MCMC Determination No. 2 of 2021, *Commission Determination on The Mandatory Standards for Quality of Service (Wireless Broadband Access Service)*

## **MCMC MTSFB TC G011:2023**

MCMC Determination No. 3 of 2021, *Commission Determination on The Mandatory Standards for Quality of Service (Public Cellular Service)*

MCMC Class Assignment No. 2 of 2022

MCMC MTSFB TC G024:2020, *Technical Code Fixed Network Facilities - In-Building and external*

MCMC MTSFB TC G040:2023, *Radiocommunications Network Facilities - External Infrastructure Specifications (First Revision)*

BS 6004, *Electric cables. PVC insulated and PVC sheathed cables for voltages up to and including 300/500 V, for electric power and lighting*

BS 7430, *Code of practice for protective earthing of electrical installations*

Institute of Electrical Engineers (IEE), *Wiring Regulations* (Ed. 17<sup>th</sup>).

UL 1449, *Standard for Surge Protective Devices*

### **3. Abbreviations**

For the purposes of this Technical Code, the abbreviations in Annex A apply.

## **4. Civil, Mechanical and Electrical (CME) requirement**

### **4.1 Equipment enclosures**

Equipment enclosures in the form of a closed or open space is the provision from the developer or owner of the building. The number of Network Service Providers (NSPs) willing to provide services are dependent on their market assessment of the building's potential traffic.

In most instances the NSPs will only require an open space with 3 phase Alternating Current (AC) supply where they can install their outdoor telecommunications equipment which comprises of the Base Band Unit (BBU) and Remote Radio Unit (RRU) which are either pole or wall mounted and equipped with power backup and cooling system.

For multiple NSPs environment, the same 60 A Triple Pole Neutral (TPN) Power Distribution Unit (PDU) will supply power to the equipment cabinets and RRUs which will be replicated according to the number of NSPs as illustrated in Figure 1.

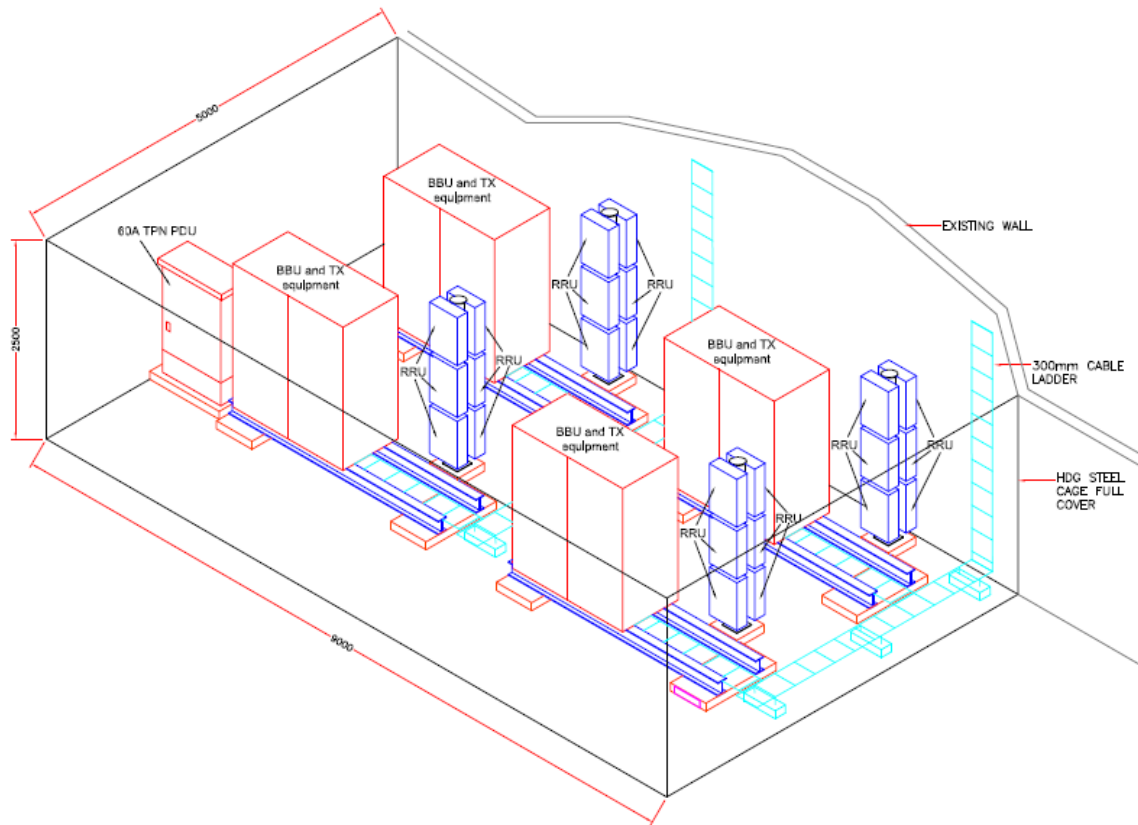
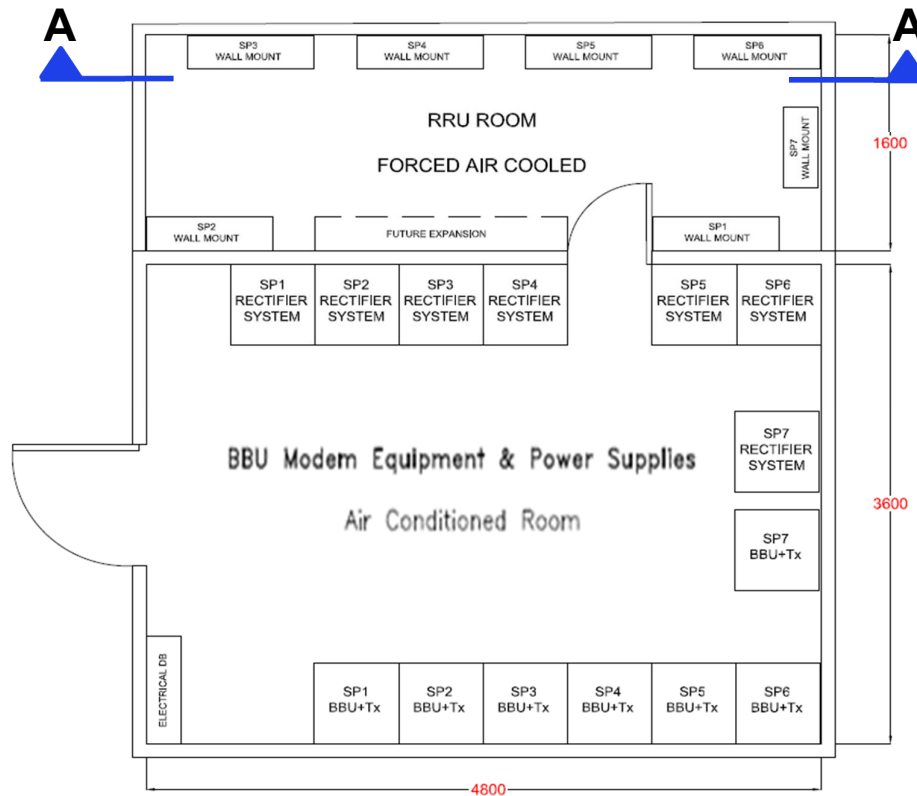

**Figure 1. Telecommunication room in the form of an open space measuring 5 m x 9 m for up to 4 NSPs**

If a room is provided, the typical layout shall be as shown in Figure 2. In this layout the RRU are co-located with the rest of the network elements such as the head end BBU, rectifiers and modems equipment.

The telecommunication room for mobile services is different from the telecommunication room described in MCMC MTSFB TC G024.

**MCMC MTSFB TC G011:2023**



**Figure 2. Fully enclosed telecommunication room measuring 4.8 m x 5.2 m**

Sufficient space should be allocated for future expansion of telecommunications equipment or for new service providers. The Building Management (BM) should discuss with the NSPs for sites which require larger installations than what is shown in Figure 3 (i.e. multiple-sector sites).

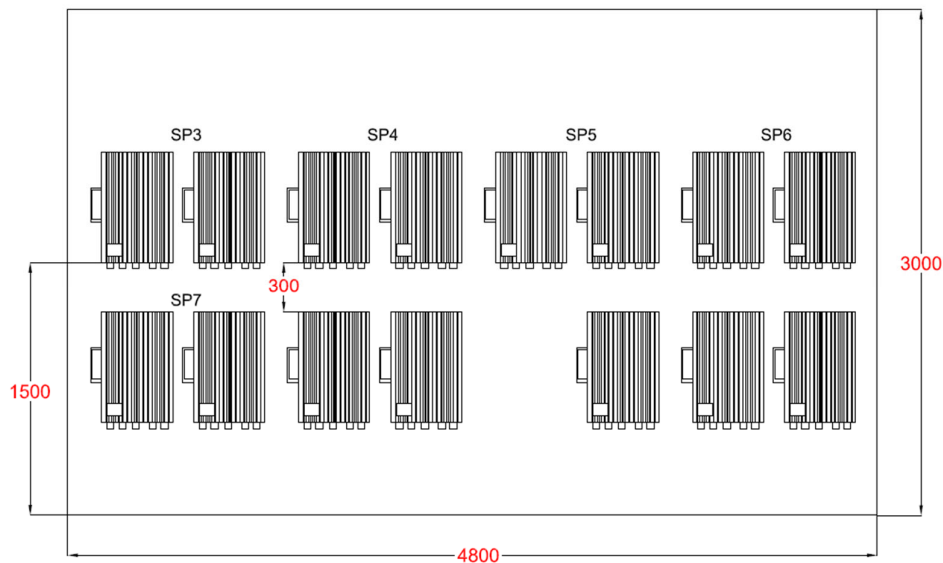

**Figure 3. Part of telecommunication room with wall mounted RRUs (section A-A of Figure 2 view)**

#### 4.2 Floor loading

Both distributed and concentrated floor loading needs to be considered with large installations where many NSPs are present. The heaviest concentrated loads will be imposed by the cabinets housing the rectifier system. The backup batteries inside these 600 mm x 600 mm cabinets weight about 900 kg.

The typical residential floor loading capacity of 1,500 kg/m<sup>2</sup> could be further strengthened with the use of supporting I-beams underneath the equipment enclosure if unusually heavy rectifier systems are used. Figure 4 illustrates an enclosure which may represent an installation of indoor or outdoor equipment supported by such beams.

Professional services of a Civil and Structural (C&S) professional engineer shall be engaged for such critical installations. Commercial buildings are not expected to pose any issues with loading concerns.

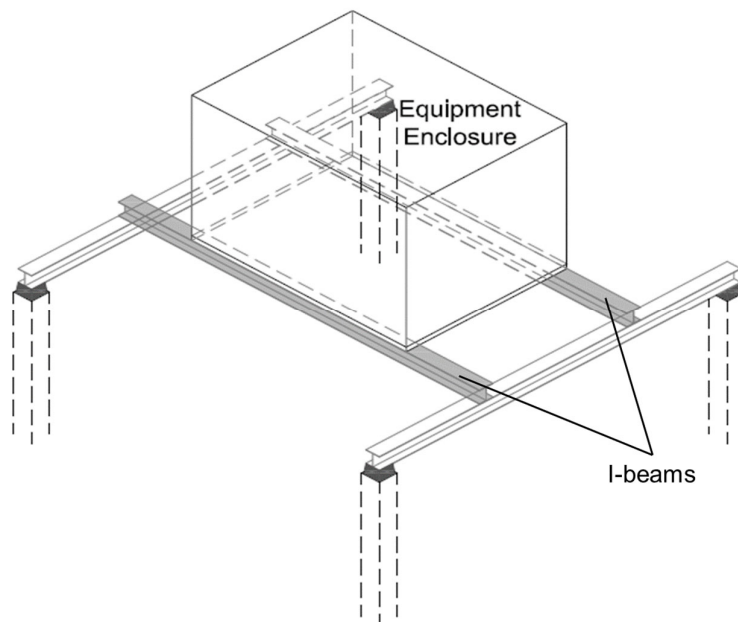

**Figure 4. Distribution of concentrated loads through the use of I-beams**

#### 4.3 Riser size

Large commercial buildings are normally equipped with a separate riser for telecommunication services. The allocation of riser space for mobile service cabling shall be according to requirement specified in MCMC MTSFB TC G024.

The cellular services shall make use of a separate cable tray from the fixed network and broadcast services. The size of this tray is according to Table 1.

## MCMC MTSFB TC G011:2023

Table 1. Cable tray size for mobile services

Network architecture	Cable type	Size of tray (mm)
Active DAS	Fibre	100
Distributed RRU DAS or hybrid solution	Fibre with coaxial	150
Passive DAS	Coaxial	150

### 4.4 Cable ladders and cable supports

Cable ladders shall be made of galvanised mild steel where they are exposed to the elements. Typical width of cable ladders shall be 150 mm or 200 mm.

For indoor applications, cable trays are required for all horizontal cabling runs and shall be epoxy coated or Galvanized Iron (GI) type.

Horizontal feeder runs above plaster ceilings shall use hanging pathways with adequate supports as shown in Figure 5. With the exception of small jumper cables or pig-tails, no coaxial cables shall be allowed to rest on the false ceilings.

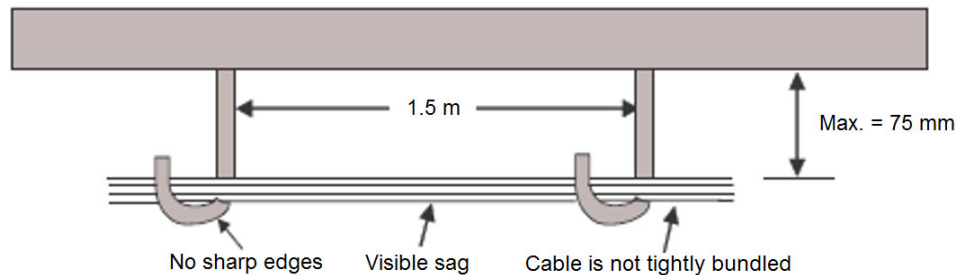

Figure 5. Hanging pathways for coaxial cables running above false ceilings

This is also applicable for ethernet cable (e.g. CAT5/6e) where the cable shall be laid inside Polyvinyl Chloride (PVC) pipe for protection.

### 4.5 Fire extinguisher

A fire extinguisher shall be provided, and it should be wall mounted and of the handheld type. The fire extinguisher is to have a test label attached with the original date of issue marked on the manufacturer's name.

### 4.6 Security facility

For telecommunication room doors, if more than one equipment enclosure is utilised, the equipment enclosure door shall be provided with a reed relay switch door for contactor to monitor site access.

### 4.7 Climate control system

This sub clause covers the cooling requirement of the telecommunication room only as outdoor equipment comes with its own climate control system. The requirements for temperature and humidity shall be met in accordance with the environmental specifications for the equipment. Equipment should in general comply to ETSI 300 019-1. The temperature indicated in 4.7.1 are typical values.

**4.7.1 Air-conditioning**

The telecommunication room shall be equipped with 2 unit of split air conditioners operating in alternate mode of 6 hourly cycles. The cooling capacity will depend among other things, on the amount and type of equipment installed inside the telecommunication room. Typical configuration will be using 2 HP units with 6 hourly alternate operations.

Target operating temperature is between 25 °C - 30 °C with relative humidity of 40 % - 60 % and is specified mostly for the benefit of the backup battery optimum operating range.

The short-term temperature range of the equipment is between 50 °C - 70 °C with short-term relative humidity between 5 % - 90 % non-condensing. These are considered as environmental extremes which if allowed to persist for any appreciable period of time would result in permanent equipment damage or irreversible performance degradation.

**4.7.2 Forced air cooling**

The ventilation fans should preferably power by the rectifier system through an inverter for sustained operations during power outages. To extend battery life the inverter should be installed with a reduced power option whereby the extraction rate of the fans is reduced.

The fans shall meet the minimum of the following requirements.

- a) 300 mm diameter with a low profile of 150 mm in depth.
- b) Fan mounted on a suitable diaphragm plate with rubber vibration mounts.
- c) Flow rate of 2 000 m<sup>3</sup>/h at 30 Pa static pressure.
- d) Power consumption approximately 100 W.

**4.8 Power supply system**

**4.8.1 Alternating Current (AC) supply**

Radio equipment are invariably powered by - 48 VDC supply. Each NSP will supply their own Direct Current (DC) or rectifier system that comes complete with battery banks for backup.

A typical load schedule for a telecommunication room supporting up to 7 NSPs is outlined in the Table 2.

**Table 2. Load schedule**

Load description	Connected load (W)	Quantity	Total connected load (W)	Diversity	Max demand (W)
Rectifier NSP1	2 500	3	7 500	0.5	3 750
Rectifier NSP2	2 500	3	7 500	0.5	3 750
Rectifier NSP3	2 500	3	7 500	0.5	3 750
Rectifier NSP4	2 500	3	7 500	0.5	3 750
Rectifier NSP5	2 500	2	5 000	0.5	2 500
Rectifier NSP6	2 500	2	5 000	0.5	2 500
Rectifier NSP7	2 500	2	5 000	0.5	2 500
Air conditioner	2 500	2	5 000	0.5	2 500

## MCMC MTSFB TC G011:2023

Table 2. Load schedule (continued)

Load description	Connected load (W)	Quantity	Total connected load (W)	Diversity	Max demand (W)
Ventilation fans	120	2	240	1.0	240
Room lighting	38	4	152	0.5	76
Switch socket outlets (SSO)	250	2	500	0.1	50
Keluar sign	5	1	5	1.0	5
Emergency lighting	25	2	50	0.1	5
Sub-total load					25,376
Spare capacity 20 %					5,075
<b>Grand total load</b>					<b>30,451</b>
<b>Current (amps)</b>					<b>127</b>
<b>TPN current at 0.9 Power Factor (PF) (amps)</b> <i>*Line to neutral voltage</i>					<b>47</b>

The telecommunication room shall be equipped with minimum requirement of 60 A 3 phase supply.

All relevant documents for submission shall be duly endorsed by a professional engineer registered with Board of Engineers Malaysia (BEM).

Redundancy in the form of essential supply from a generator set is recommended in view of the ubiquitous use of handphones nowadays. People caught inside faulty lifts or trapped in a fire or flood situation will have an avenue to make emergency calls.

### 4.8.2 Mains power distribution system

The mains power distribution system should consist of an intake point located on the floor of the telecommunication room and a power distribution board. This is a 3 phase metal clad type fitted with the necessary Main Circuit Breaker (MCB).

A circuit schedule shall be affixed to the inside of the front cover of the distribution board, neatly presented and enclosed within a clear plastic envelope. Labelling should be provided to comply with Wiring Regulations (Ed. 17<sup>th</sup>).

### 4.8.3 Wiring system

The wiring system comprised of copper or PVC single insulated cables complied to BS 6004. The cables should generally be installed within a conduit or trunking in a neat and tidy manner.

Sizing of all electrical cables shall take into account voltage drop, grouping, and environmental conditions in accordance with Wiring Regulations (Ed. 17<sup>th</sup>).

### 4.8.4 Small power installations

Surface mounted twin SSO shall be provided for test equipment and other maintenance appliances. They shall be located one on opposite corners of the telecommunication room and in riser spaces at every floor where the mobile telecommunication equipment installed.

#### **4.8.5 Lighting**

The telecommunication room shall be provided with ceiling mounted high efficiency fluorescent lighting giving at least 300 lux at floor level. Emergency lighting and *Keluar* signs may also be provided. These should be considered as essential loads and powered from the rectifier system.

Switches for the control of light fittings should be provided at the entrance just inside the telecommunication room. Perimeter lighting if desired as in the case of car park or rooftop installation with outdoor equipment is of the flood light type using 200 W Sodium Vapour Lamp (SON) bulbs. Switches for the control should be provided at the common Distribution Box (DB).

#### **4.8.6 Mechanical and Electrical (M&E) control and alarm signalling cables**

A common distribution frame should be used to terminate all control and alarm signalling cables for the site. Individual alarm termination junction boxes are not allowed to avoid cluttering and untidy cabling in the telecommunication room.

Alarm contacts should be voltage free and relays of the single-pole-double-throw type, operated by 48 VDC supplies.

#### **4.8.7 Lightning surge protection system**

The supplier or local agent of the protection equipment shall be able to provide full technical and continuous engineering support in the event of any lightning, surge, or grounding problems. As such it is mandatory that the local agent shall have at least 5 years proven experience in the lightning and surge protection field or hold an agency or representation in lightning surge products for at least 10 years.

It is also important that they shall have qualified engineers, trained technicians and appropriate laboratory equipment to ensure that their products are compatibly matched with power supply safety requirements. The supplier shall submit their company profile in terms of technical support personnel, availability of laboratory equipment and schedule of proven past relevant projects.

A warranty certificate shall be obtained from the local authorised agent stating clearly a full 2 years warranty against both materials and workmanship defects.

Lightning surge protection devices shall be tested by international laboratories in accordance to UL 1449. Arrester shall be built-in with thermal disconnection protection.

The suppressors are shunt type and shall be suitable for use with 3 phase supply of 415 V, 50 Hz and equipped with a 4 pole MCB. All surge suppressors installed in all boards in a particular site shall be of the same manufacturer and fully coordinated to provide maximum protection to the equipment.

The type and ratings of the suppression devices shall be specified according to their application in the site. This multistage protection shall consist of at least a primary and a secondary stage installed at the metering cabinet intake point and at the Alternate Current Power Distribution Box (ACPDB) inside.

The GPS antenna feeder shall be equipped with an arrester to protect the BBU in the case of GPS antenna being struck by lightning.

#### **4.8.8 Earthing facility and cross bonding**

The earthing of the electrical installation should comply with the requirements of Wiring Regulations (Ed. 17<sup>th</sup>). Code of practices for the earthing of equipment and system earthing shall be according to BS 7430.

## MCMC MTSFB TC G011:2023

Equipotential bonding of structures should be implemented throughout the station for protection against lightning. This entails specification of materials used and procedures to adopt if it is desirable to provide protection for the Antenna Mounting Structure (AMS). Telecommunication rooms which are normally installed close to the AMS and within its 30° zone of protection are considered protected.

The earthing scheme adopted for the internal of the telecommunication room is illustrated in Figure 6. All incoming RF feeders into the telecommunication room are earthed using its supplied earthing kit. The collection of all the earthing lugs is terminated onto a common earth copper bar installed at high level adjacent to the telecom cabling entry gland. This earth bar is connected to a Main Ground Bar (MGB) which collects all the other earth terminations such as chassis and cable ladders. No connection is made between the MGB and the 'system earth' bar or electrical earth bar. The two earth bars are only bonded below ground level at the earth pits.

Ground bus conductors to the MGB should use 50 mm<sup>2</sup> green or yellow ground cables as a minimum. A clean ground should be provided for the MGB with an impedance not exceeding 10 Ω.

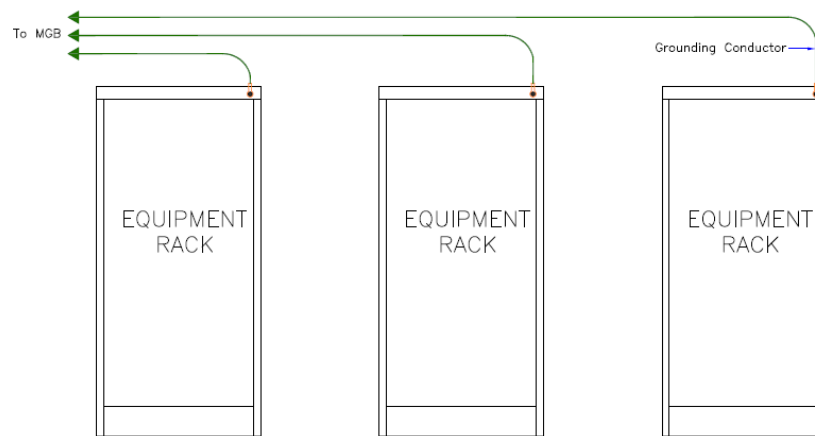

Figure 6a. Front view

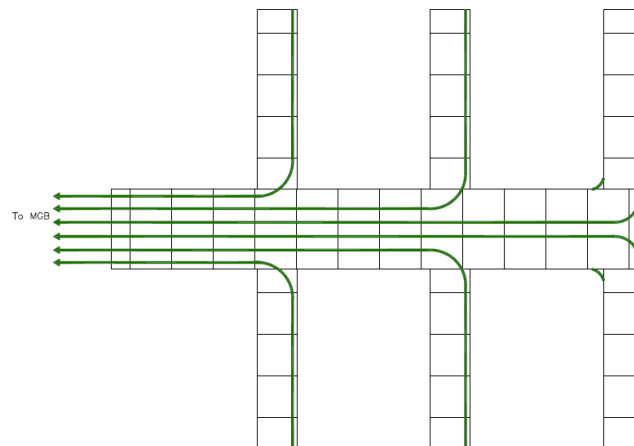

Figure 6b. Plan view illustrating grounding conductor routing on the cable ladder

Figure 6. Connecting to the MGB in a star-topology

**4.9 Global Positioning System (GPS)**

Long Term Evolution (LTE), LTE-advanced and 5G New Radio (NR) services have frequency, phase and time synchronisation for each cell site as well as neighbouring cell sites. A GPS antenna system as shown in Figure 7 is commonly used in the mobile network for the frequency, phase and time synchronisation.

The half inch coaxial cable shall be used to connect the GPS antenna and the BBU. The positioning of the GPS antenna should have a clear view of the sky without any obstruction. GPS antenna shall be installed as near as possible to the BBU with a length limitation of 100 m for coaxial cables. Additional booster to be install if the length is more than 100m. The Voltage Standing Wave Ratio (VSWR) should be as per derived in Table 9. The GPS coaxial cable run should be as per 4.4.

The common installation scenario will be wall-mount at the building rooftop. In-case of telecommunication room located at basement floor, the GPS antenna should be installed at loading bay or parking ramp entrance or any suitable locations.

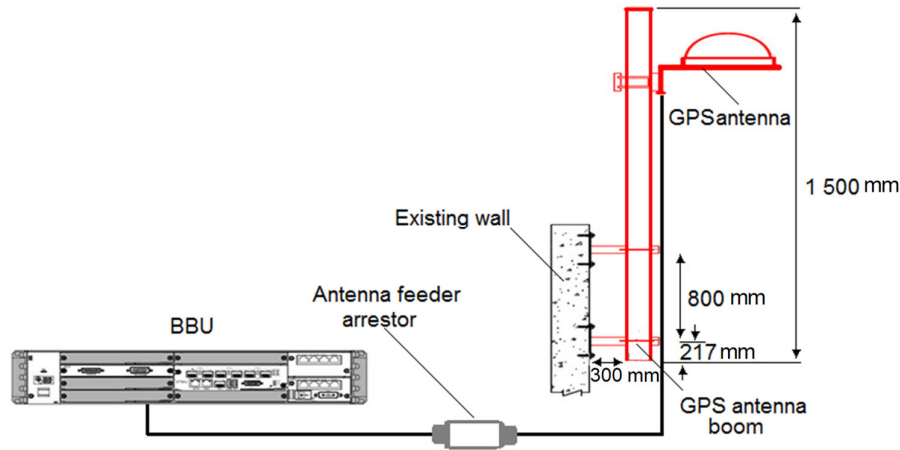

**Figure 7. GPS antenna system**

**4.10 Transmission backhaul requirement**

Transmission backhaul is inclusive of microwave transmission and fixed line fibre.

**4.10.1 Microwave transmission**

Developer or building owner is required to allocate a minimum space of 1.5 m x 1.5 m for standard 3 m floor mounted boom for each NSP at the rooftop for the installation of microwave antenna. It shall be on a flat horizontal surface without any obstructed view to other nearest sites (far-end). Size of microwave antenna is determined by the distance to far-end as stipulated in Table 3 below.

**Table 3. Size of microwave antenna**

Distance (km)	Frequency (GHz)	Antenna size (m)
0 - 1.9	23	0.6
2.0 - 3.0	18	0.6
3.1 - 4.0	18	1.2
4.0 - 5.5	15	1.2
5.6 - 7.0	13	1.2

## MCMC MTSFB TC G011:2023

The microwave systems consist of the following Indoor Unit (IDU) and Outdoor Unit (ODU) units (see Figure 8).

### 4.10.1.1 Indoor Unit (IDU)

The IDU for the system installed at the 19 inches rack or cabinet inside the telecommunication room. It receives and multiplexes services, performs service processing and Intermediate Frequency (IF) processing, and provides the system control and communications function.

### 4.10.1.2 Outdoor Unit (ODU)

The ODU performs frequency conversion and amplification of signals.

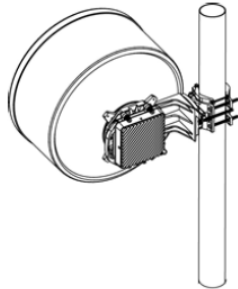

Figure 8a. ODU unit



Figure 8b. IDU unit

Figure 8. Example of ODU and IDU unit

Both IDU and ODU are connected through an IF cable. Type of IF cable to be used is depends on the distance between IDU and ODU as shown in Table 4.

Table 4. Type of IF cable

Cable length (m)	Cable type
< 250	RG8
250 - 400	Half inch coaxial cable
> 400	Fibre optic cable

The microwave antenna shall be mounted on a pole using mounting bracket. The pole can be either floor mounted (see Figure 9) or wall mounted using metal raw plug and screw on concrete base. The pole height varies from 1 m - 4 m depends on Line of Sight (LOS) to B Site. In case no suitable B sites are found because of "shadowing" by other taller buildings, a higher structure maybe erected (bigger floor space).

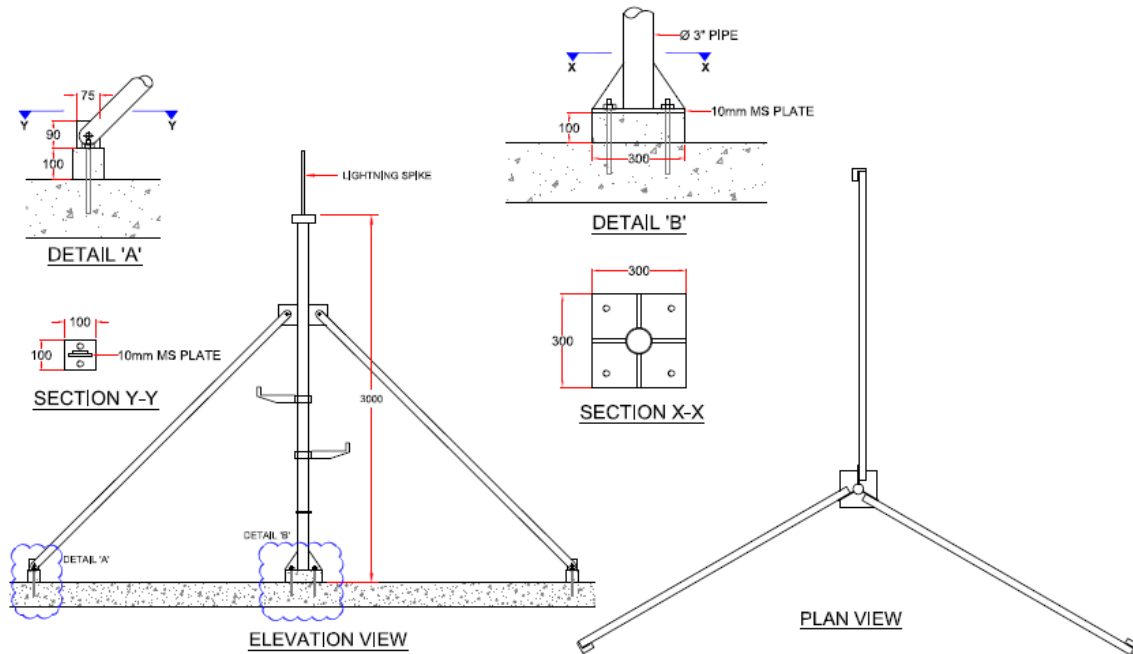

**Figure 9. Example of floor mounted pole**

The following minimum requirements shall be followed.

- a) The pole shall be grounded to the existing building lightning ground using exothermic welding or copper test bond.
- b) The transmission cable from the microwave antenna to IDU inside the telecommunication room shall be installed by the NSP. The transmission cable will run on a cable ladder or inside cable trunking to the nearest riser down to telecommunication room.
- c) Developer, NSP or Network Facility Provider (NFP) should provide a ladder (if required) to access the rooftop for the installation of transmission structure and microwave antenna. It is also required for the purpose of regular maintenance and inspection. Some sites may require walking platform for safety during site installation and maintenance.

#### **4.10.2 Fibre backhaul system**

The requirement of fibre for backhaul shall be according to MCMC MTSFB TC G024.

### **5. In-Building Coverage (IBC) Distributed Antenna System (DAS) requirement**

The 3 important aspects to consider when designing and deploying an IBC are coverage, capacity, and quality. A well-designed IBC covers the building according to the requirement specifications, i.e. mobile coverage wherever desired. The in-building cells are usually smaller than the macro cells and can thus provide greater capacity than outdoor cells. It also provides low interference levels resulting in good voice quality and better data throughput.

## **MCMC MTSFB TC G011:2023**

### **5.1 Types of IBC DAS for mobile services**

The solutions of IBC DAS for mobile services are as follows.

- a) Passive solution (centralised RRU and distributed RRU - multi RRU design or cascaded RRU).
- b) Active solution (low power Remote Unit (RU), high power RU, Digital Indoor System (DIS)).
- c) Hybrid solutions.

#### **5.1.1 Passive DAS Solution**

Passive DAS concept distributes RF signal from Base Transceiver Station (BTS) or eNode-B to antennas inside a building using coaxial cable and passive components. Passive DAS is used to cater for basic user and traffic behaviour in a building area. Due to the behaviour and standard capacity demand, IBC builders would deploy passive DAS solution to meet the customer's expectation.

The passive DAS solution concepts are as follows.

- a) Distribute RF signal from BTS or eNode-B to antennas inside a building using coaxial cable and passive components.
- b) Coaxial feeder length is limited due to losses.
- c) Passive component and coaxial feeder losses.
- d) Passive component - splitters (2, 3 or 4 ways), combiner, coupler, triplexer, quadplexer.
- e) Cost effective.
- f) Lower operational and maintenance cost.
- g) Fault detection or monitoring can only be done per sector of BTS or eNode-B, not per antenna basis.
- h) 2 RRU deployment scenarios:
  - i) centralised RRU (refer to 5.1.1.1); and
  - ii) distributed RRU - multi RRU design/cascaded RRU (refer to 5.1.1.2).
- i) If the main trunk coaxial cable is more than 150 m, it is advised to proceed with distributed RRU concept.

##### **5.1.1.1 Centralised RRU concept**

Centralised RRU concept refers to the placement of all sector RRU, whereby the RRU is located together with the BTS or eNode-B. This concept uses thicker sized coaxial cables as main trunk for RF signal to be distributed to the intended coverage area. The last mile of the DAS is passive.

Figures 10 and 11 illustrates the network architecture of passive DAS (centralised RRU concept).

The schematic diagram shows one of the examples on how to combine multi technology environment for one NSP. Refer to Annex B for combiner specifications.



## MCMC MTSFB TC G011:2023

### 5.1.1.2 Distributed RRU concept

Distributed RRU - multi RRU design/cascaded RRU concept distributes RF signal from BTS or eNode-B to antennas inside a building using coaxial cable and passive components. The difference between centralised RRU and distributed RRU concept is the placement of the RRUs. The RRUs will be placed nearer to the intended sector coverage area thereby eliminating feeder losses from the main trunk.

Figures 12 and 13 illustrates the network architecture of passive DAS (distributed RRU concept)

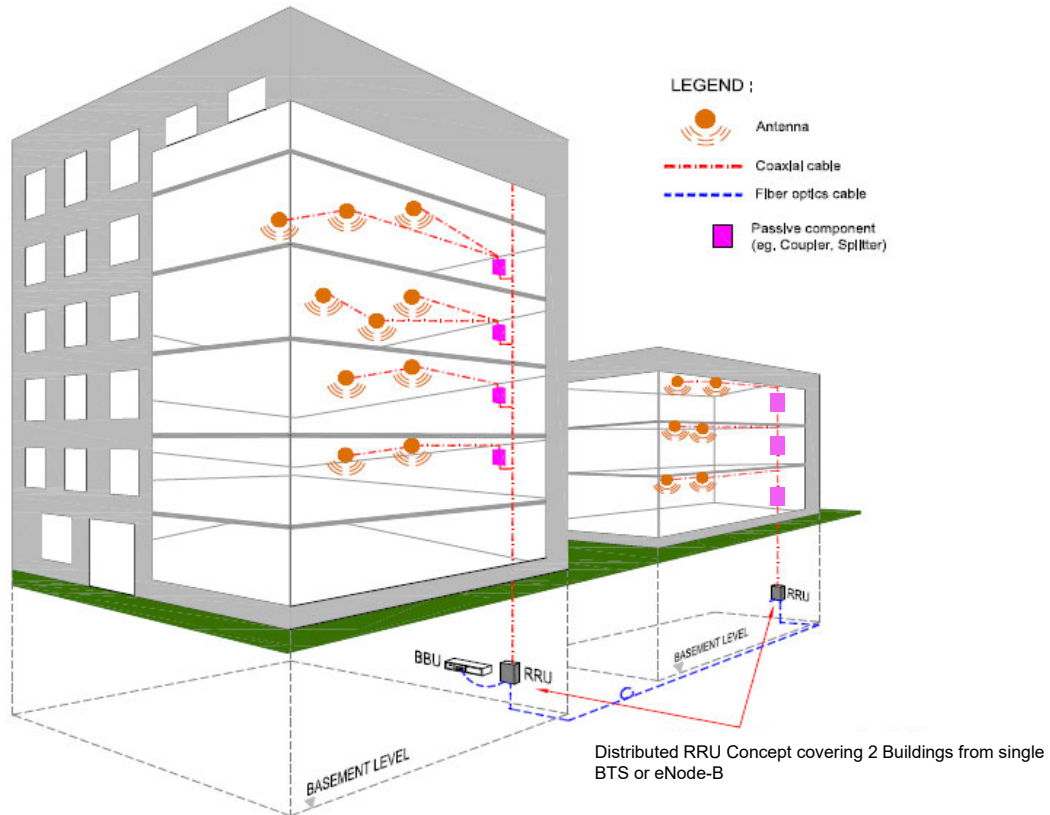

**Figure 12. Passive DAS (distributed RRU concept) covering 2 buildings from single BTS or eNode-B**

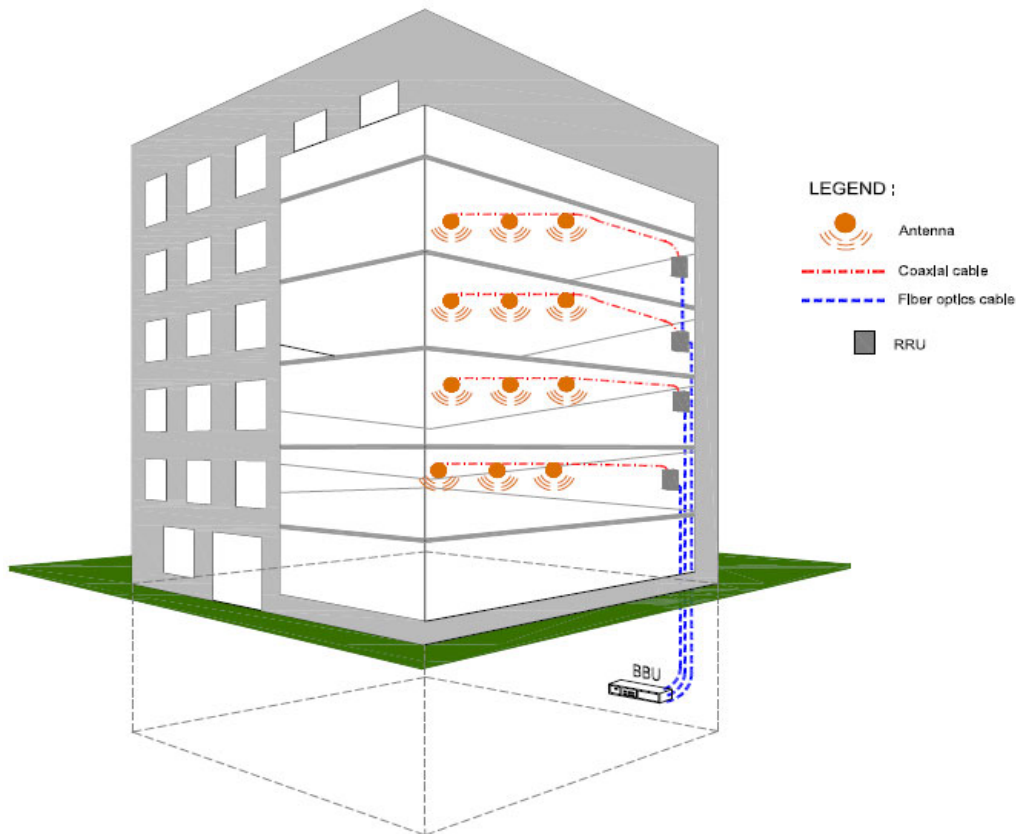

**Figure 13. Passive DAS (distributed RRU concept) covering large building**

The distributed RRU concept describe as follows.

- a) Only BBUs are installed inside the telecommunication room.
- b) RRUs are installed at different locations based on design requirement. Requires additional space for RRU and combining circuit.
- c) RRUs can be connected as star topology or cascaded topology.
- d) RRUs can be cascaded (chain topology design) based on output power requirement. Number of cascaded RRUs depends on equipment capability.
- e) Ideal for high rise building or large building complexes such as shopping malls with a lot of antennas.
- f) Common Public Radio Interface (CPRI) connection between BBU and RRU has length limitations depending on the equipment vendor.
- g) Minimises number of thicker sized coax feeders (1 5/8 inches, 1 1/4 inches or 7/8 inches) used as main cable trunk to connect between RRU and the in-building antennas
- h) Able to power up two or more buildings with single BTS or eNode-B (campus concept).
- i) Combining circuit will be at every RRU location, hence requires large space for RRU location. More technologies and increased number of sharing parties require more space.

## MCMC MTSFB TC G011:2023

The deployment is covering on medium to large size buildings, high-rise buildings, and campus concept whereby 2 or more buildings are covered with a single BTS or eNode-B (see Figure 14).

Ideal for campus environment but also suited for high rise and large buildings where multiple RRU spaces can be made available.

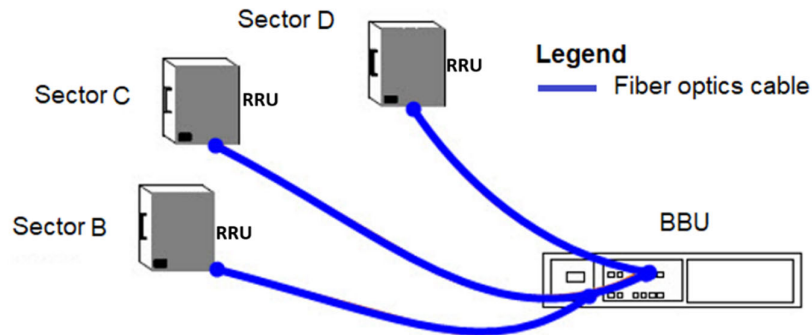

Figure 14a. Star topology

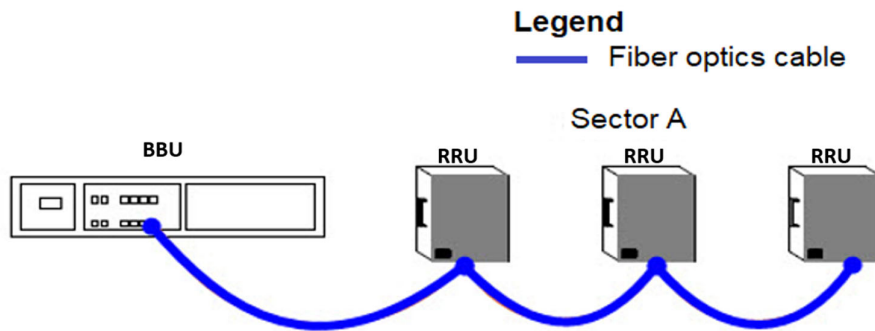

Figure 14b. Cascading topology

Figure 14. Star and cascaded RRU topology

### 5.1.2 Active Solution

Active solution can be divided into two concepts as below.

- a) Active DAS.
- b) DIS.

#### 5.1.2.1 Active DAS

Active DAS concept distributes RF signal from BTS, eNode-B or gNode-B to antennas inside a building making use of extensive amount of fibre optics and active modules that converts the optical signals back into RF signals after long distribution runs.

Active DAS is used to cater for basic user and traffic behaviour in a building area. Due to the behaviour and standard capacity demand, IBC builder would deploy active solution to meet the customer's expectation.

The active DAS concept are as follows.

- a) Distributes RF signal from BTS, eNode-B or gNode-B to antennas inside a building consisting of fibre optics and active modules.
- b) Independent of fibre length.
- c) Minimum losses (fibre-optic).
- d) Active module - Master Unit (MU) and RU. Requires extra space for MU and RU deployment.
- e) Uses extra-large amounts of Capital Expenditure (CAPEX).
- f) High maintenance cost mainly on MU and RU cost.
- g) Fault detection or monitoring at each active module for operational status.
- h) Less favourable deployment due to the high maintenance cost.
- i) Distributed RRU technology is able to replicate the active DAS deployment, BBU as MU and RRU as RU, the difference is it requires combining circuit at each RRU location and a large space/wall space is needed if multiple operator and technology is required.
- j) Attenuation settings require equipment professionals for support. Professional support expires once the active DAS infra warranty expires.
- k) There are two deployment concepts for active DAS as follows:
  - i) low power RU (refer to 5.1.2.1.1); and
  - ii) high power RU (refer to 5.1.2.1.2).

#### **5.1.2.1.1 Low power RU active DAS**

An active DAS concept distributes RF signal from BTS, eNode-B or gNode-B to the antenna through an active unit which consists of a main unit, expansion unit and RU. Before entering the main unit, attenuator is used to attenuate the signal power. The main unit converts the RF signal to optical signals and distributes through fibre optic cables to the expansion unit. The length of the fibre optic cable depends on the type of optical cables used, either single mode fibre or multi-mode fibre. From the expansion unit, the signal is distributed through CAT5e or CAT6e cables to a RU. There are length limitations for the CAT5e cable. The low power RU demodulates the signal to RF Signals and amplifies the signal before transmitting it through an Antenna. Each low power RU connects to a single antenna.

Figure 15 illustrates the network architecture of low power RU active DAS schematic diagram.

**MCMC MTSFB TC G011:2023**

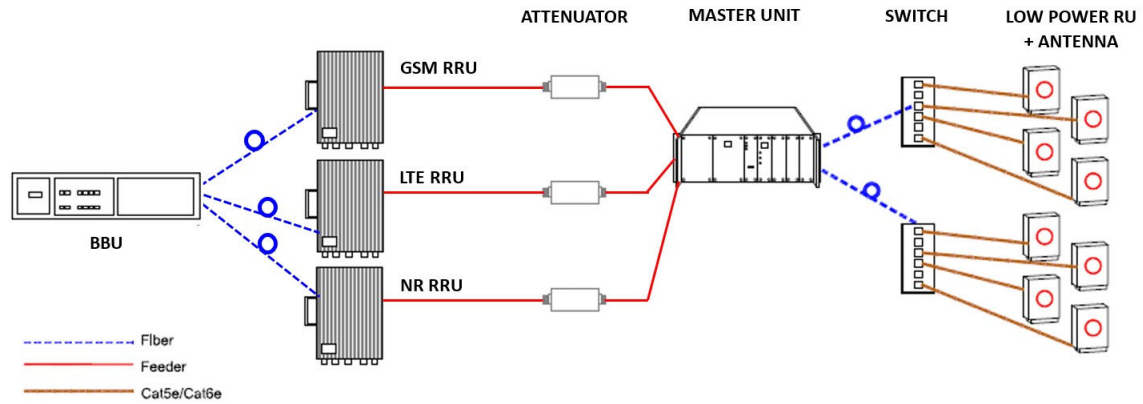
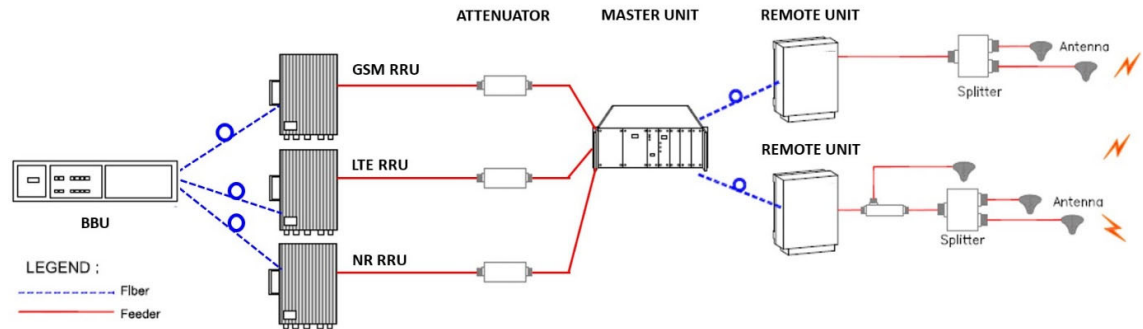

**Figure 15. Low power RU active DAS schematic diagram**

**5.1.2.1.2 High power Remove Unit (RU) active DAS**

A high-power RU active DAS concept is almost the same as a low power RU active DAS concept. The only difference is the architecture after the RU, whereby a high-power RU is able to support multi antenna for each RU. The antenna is connected using coaxial cables and passive components from the RU.

Figures 16 and 17 illustrates the network architecture of high-power RU active DAS.



**Figure 16. High power RU active DAS schematic diagram**

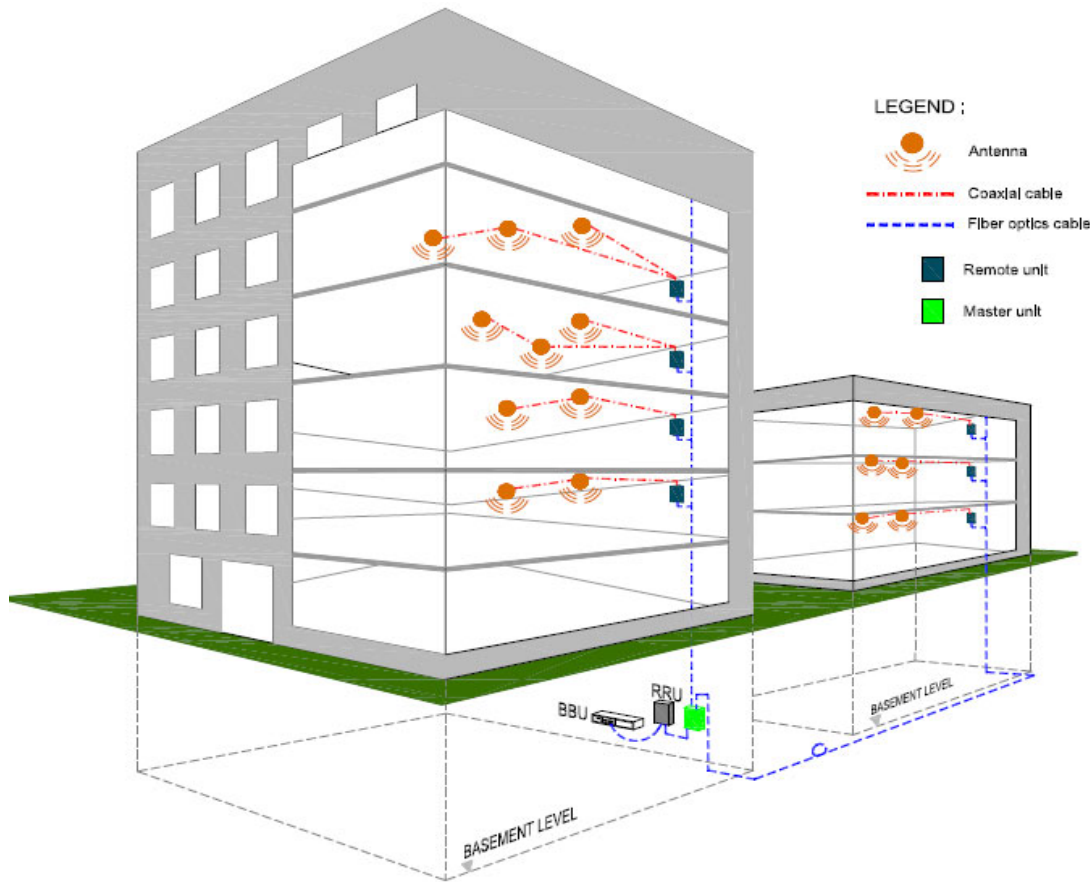

**Figure 17. High-power RU active DAS covering 2 buildings**

The deployment covering over large areas for multiple cellular services irrespective of carrier frequency or technology, long distance tunnels and a campus concept where 2 or more buildings are covered with a single BTS, eNode-B or gNode-B.

#### **5.1.2.2 Digital Indoor System (DIS)**

In DIS, optical signal is distributed from BBU to multiple switches through fibre optic cables. The switch will split the baseband data to different routes and send it to the digital antenna. The internal Power over Ethernet (PoE) module in the switch will provide DC power to the digital antenna. DIS can support multi frequency and multi operator.

Figures 18 and 19 illustrates the network architecture of DIS solution.

**MCMC MTSFB TC G011:2023**

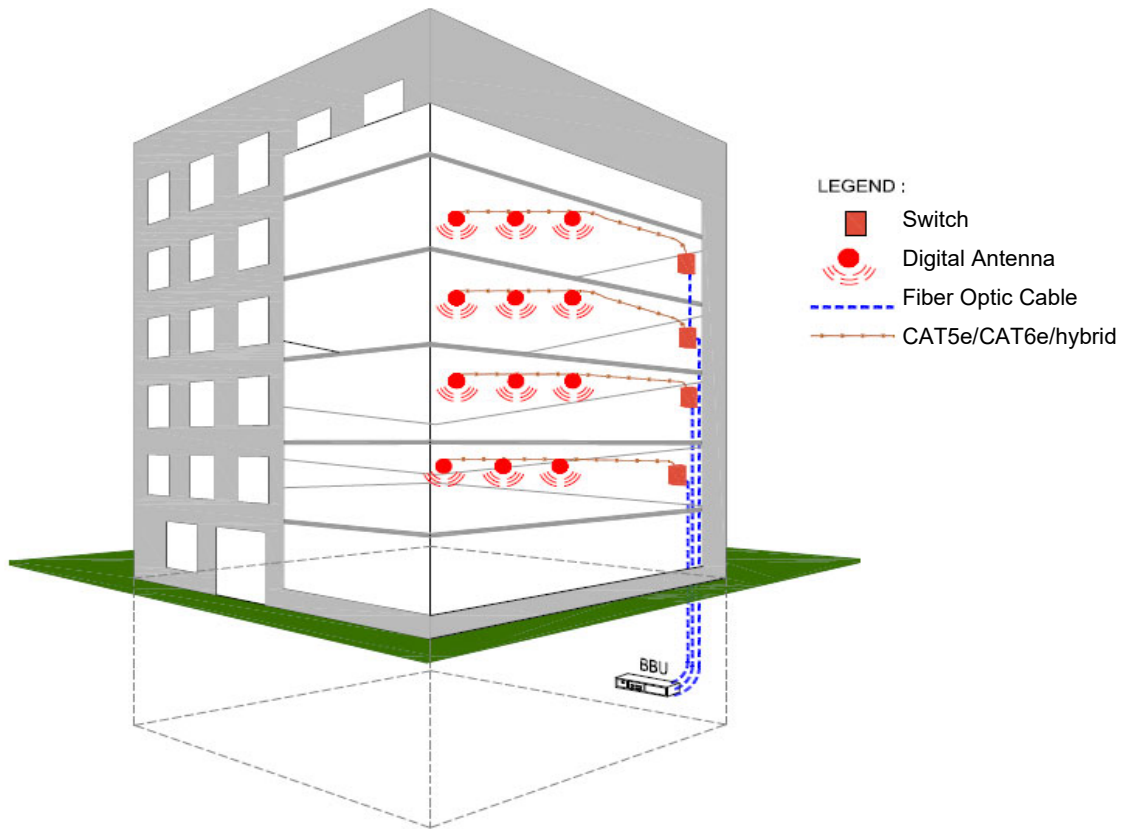

**Figure 18. DIS solution**

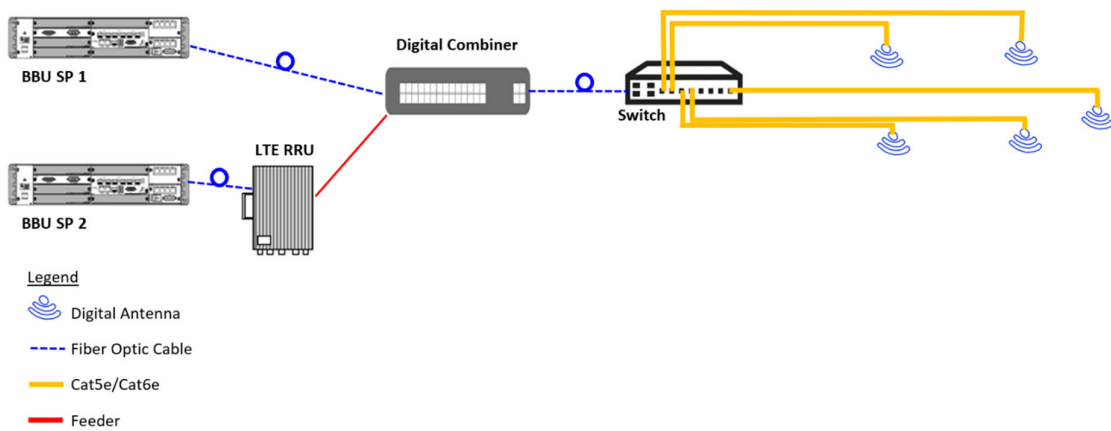

**Figure 19. DIS schematic diagram**

The DIS deployment concept are as follows.

- a) Minimum output power of digital antenna is 250 mW.
- b) Can be deployed in multi operator scenario.

- c) Each digital antenna able to transmit multi technology and frequency depending on the equipment capabilities.
- d) For capacity purposes, the sectorisation can be scalable with software configuration only. The sector can be configured through switch basis or digital antenna.
- e) The maximum number of sectors depending on the BBU board capabilities.
- f) The switch will have certain port limitations for number of digital antennas that can be connected.
- g) A single switch can be connected or cascaded up to a certain number based on equipment capabilities from a single BBU port.
- h) Each element of DIS can be monitored from monitoring system.
- i) DIS should support a minimum of 2 x 2 Multiple-Input Multiple-Output (MIMO) by default.
- j) Able to support future proof technology (e.g. indoor device location positioning and traffic heatmap).

DIS infrastructure shall be vendor neutral where the equipment may come from multiple vendors or brands for end-to-end deployment. The equipment shall be compatible to support multi-service provider sharing scenarios by using a digital combiner that can combine equipment from other vendors or brands.

### 5.1.3 Leaky feeder solution

A passive feeder solution or leaky feeder concept is to cater for unique deployment scenarios with standard user traffic behaviour in a building. Due to the balanced user traffic behaviour and standard capacity demand, an IBC builder would deploy leaky feeder to meet the customer's expectation.

Network architecture of leaky feeder solution is illustrated in Figure 20.

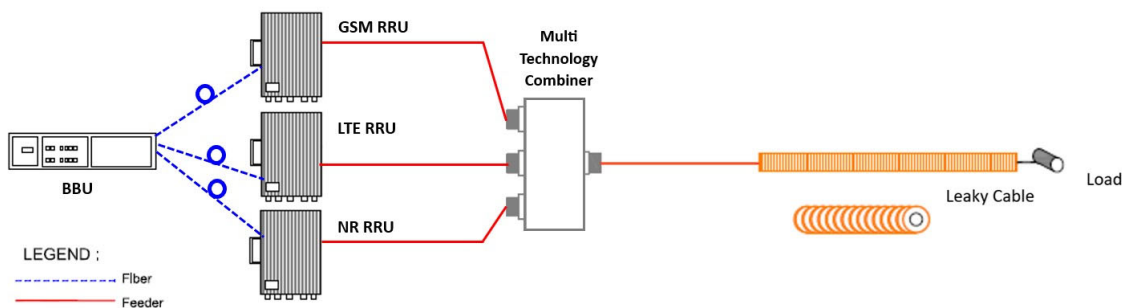

Figure 20. Schematic diagram of leaky cable deployment

The leaky feeder concepts are as follows.

- a) Distributes RF signals from BTS, eNode-B or gNode-B through leaky feeder/radiating cable. Coaxial emits and receives radio signal. It acts as extended antenna.
- b) Coaxial feeder length is limited therefore amplifiers are required to boost the signal.
- c) Large amount of CAPEX.
- d) High maintenance cost.

## MCMC MTSFB TC G011:2023

- e) Alarm monitor available per sector of BTS, eNode-B or gNode-B.
- f) Each leaky cable needs to be customised to the required frequency. If an additional frequency is required, a new leaky cable will need to be customised.

The deployment covers short to long distance tunnels, caves and high-speed lifts.

### 5.1.4 Hybrid solution

Hybrid solution is a combination of 2 or more options from each concept in 5.1.1, 5.1.2, and 5.1.3. A hybrid solution is used to cater for multi user and traffic demands in a building area. Due to the building size/traffic demand/technology evolution, an IBC builder would deploy a hybrid solution to meet the customer's expectation.

For example, the hybrid solution can be a combination of passive DAS, active solution and leaky cable. Figures 21 illustrates a few examples of hybrid solution deployment.

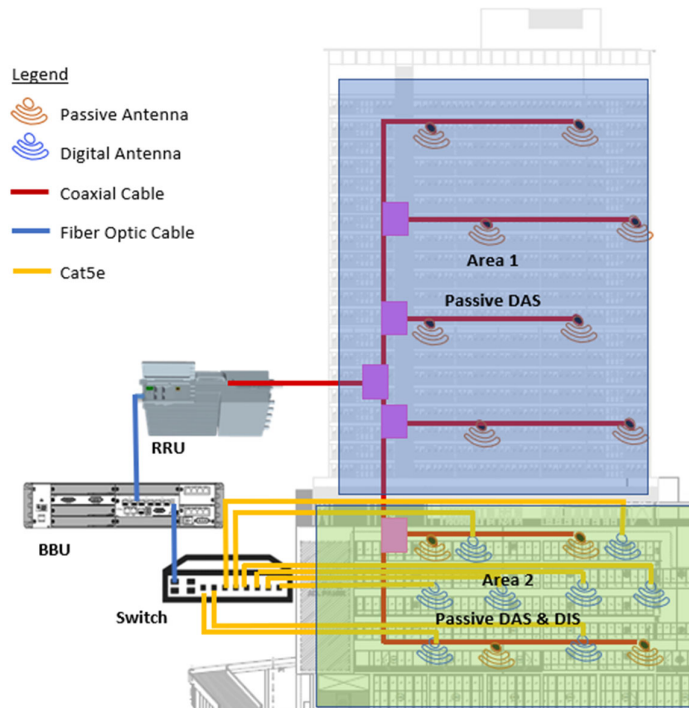

Figure 21a. Hybrid solution - passive DAS and DIS

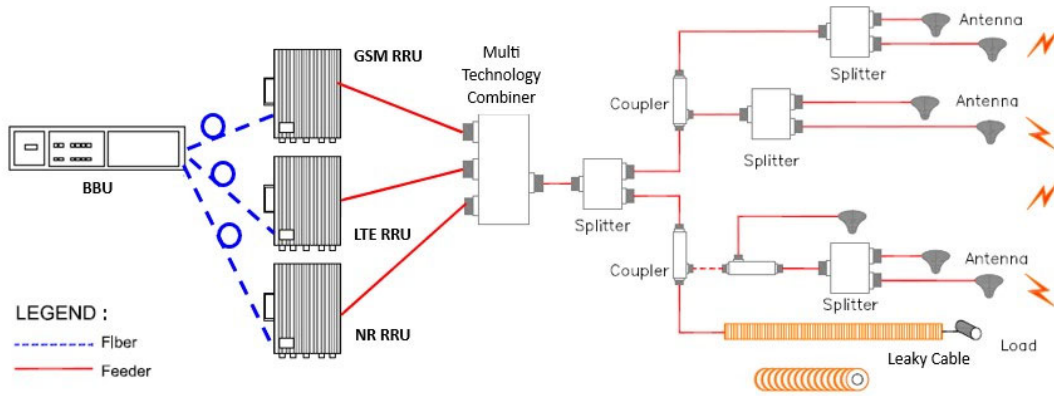

Figure 21b. Hybrid solution between passive DAS and Leaky cable

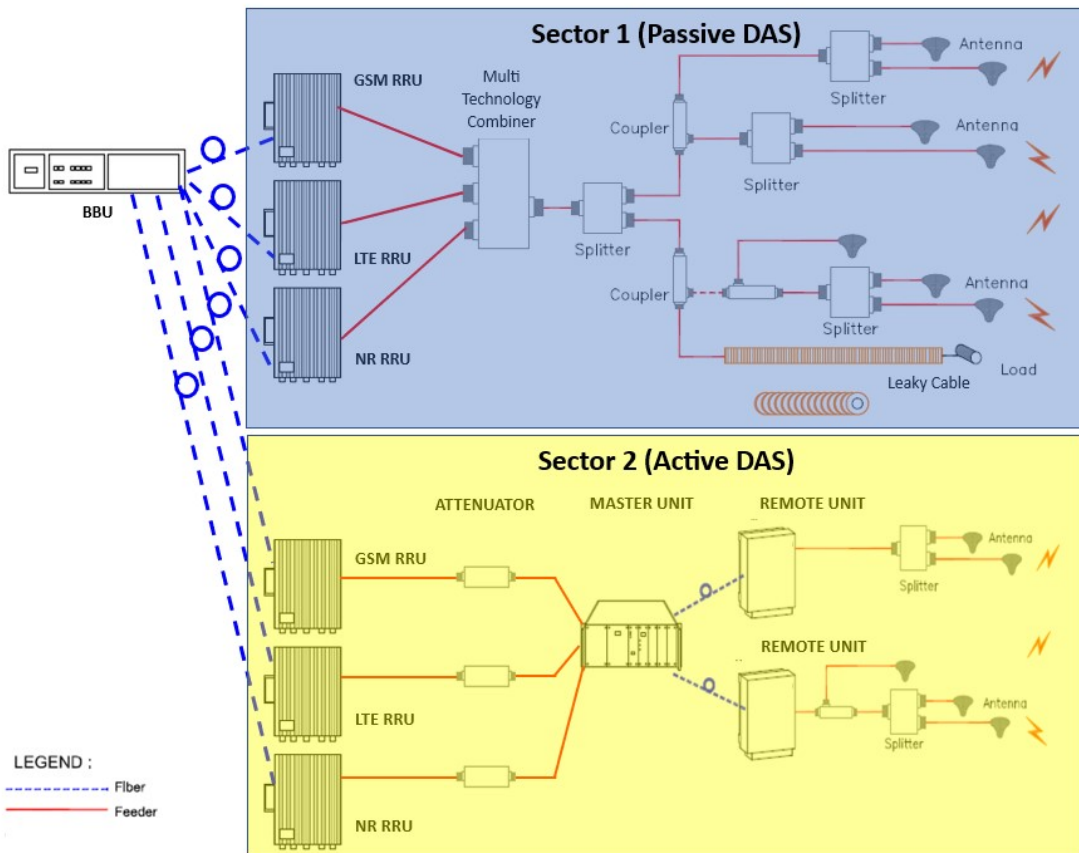

Figure 21c. Hybrid technology between passive DAS and active DAS

Figure 21. Network architecture of a hybrid technologies

## MCMC MTSFB TC G011:2023

The hybrid solution combination can be either concept covering different floors, for example Passive DAS concept covering higher floors and Active DAS covering lower floors or both concepts can be collocated covering same floors, for example passive DAS and DIS collocated covering lower floors with either one transmitting different technologies or different frequency band.

The hybrid solution deployment covering over extra-large areas for multiple cellular services irrespective of carrier frequency or technology. High capacity demands and buildings having multi user traffic behaviour.

### 5.2 Wireless Fidelity (WiFi) installation

WiFi is an optional service to commercial building. Figure 22 shown a typical basic WiFi installation.

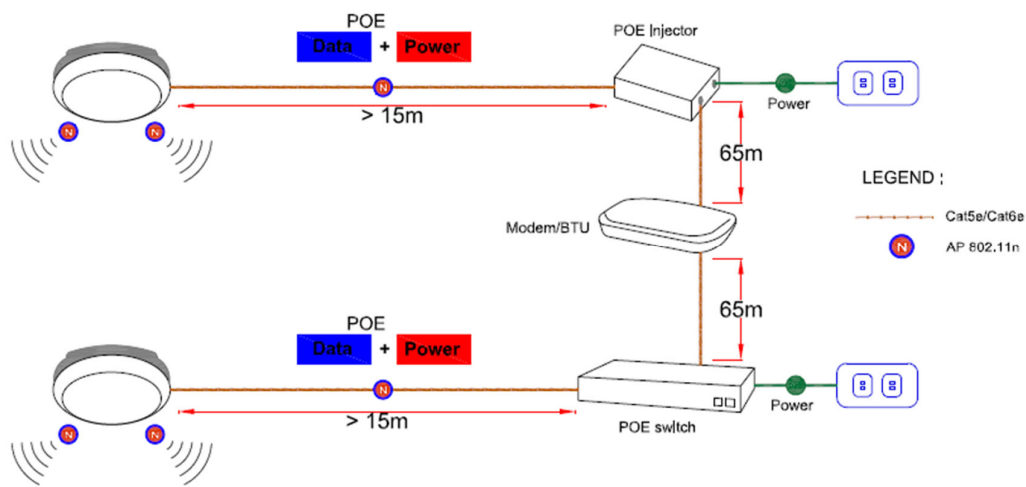

**Figure 22. Typical WiFi installation**

Typical backhaul deployment is using fixed network/backhaul. Basic equipment for WiFi deployment by operators are as follows.

- Modem or Broadband Termination Unit (BTU).
- Switch.
- PoE injector.
- Access Point (AP).
- Power sockets.
- Cables (minimum of CAT5e).
- Fibre media converter for conversion from fibre cable to CAT5e (RJ45).

Actual deployment will vary upon technical proposal by the operator's requirements to deploy WiFi. Building owners shall ensure AP placement provides coverage towards crowd focused areas or intended coverage area.

There are 2 types of AP placement as follows (see Figure 23).

- a) Ceiling placement.
- b) Wall-mounted.

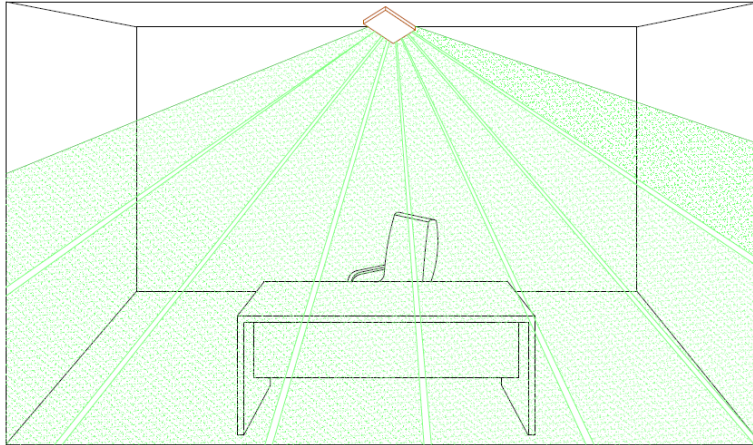

**Figure 23a. Ceiling placement**

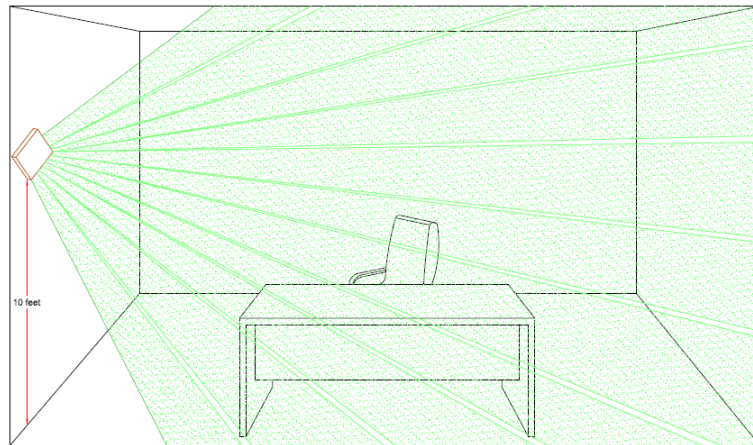

**Figure 23b. Wall-mounted**

**Figure 23. Types of AP placement**

There are 4 scenarios of WiFi cabling approach. Please refer to Annex C.

### **5.3 Key Performance Index (KPI)**

#### **5.3.1 Wireless Fidelity (WiFi) KPI**

WiFi systems are designed by WiFi providers according to user requirements. Actual deployment will vary upon technical proposal by the operators wishing to deploy WiFi. For optimum coverage, building owner need to ensure AP placement provides coverage towards crowd focus area or intended coverage area. User acceptance and verification tests for WiFi systems are performed according to each individual WiFi providers test criteria that are consistent with the allocations, technical parameters and condition specified in MCMC Class Assignment No. 2 of 2022.

## MCMC MTSFB TC G011:2023

### 5.3.2 Distributed Antenna System (DAS) KPI for mobile

For details of Quality of Experience (QoE), refer to Annex D.

#### 5.3.2.1 Coverage area definition

The coverage area definition for various networks are specified in Tables 5.

**Table 5. Coverage area definition for GSM 1800, LTE FDD 850, LTE FDD 2100, LTE TDD 2300, LTE FDD 2600 and NR3500**

Coverage area definition	Simulation/ Walk test colour scheme
Primary areas (P1)	Green
Secondary areas (P2)	Yellow
No access	Red
Not covered	Grey

#### 5.3.2.2 Coverage area percentage

The following abbreviations are applied for Table 6 to 8.

- a) RSRP is Reference Signal Received Power.
- b) RSRQ is Reference Signal Received Quality.
- c) SINR is Signal to Interference & Noise Ratio
- d) ICU is Intensive Care Unit.
- e) VVIP is Very Very Important Person.
- f) NR is New Radio.

The coverage area for GSM 1800, LTE FDD 850, LTE TDD 2300, LTE FDD 2100, LTE FDD 2600 and NR3500 are specified in Tables 6 and 7.

**Table 6. GSM 1800, LTE FDD 850, LTE TDD 2300, LTE FDD 2100, LTE FDD 2600 and NR3500 P1 coverage area**

P1 coverage area	GSM 1800 (Rx Lev)	LTE FDD 850 (RSRP)	LTE TDD 2300 (RSRP)	LTE FDD 2100/2600 (RSRP)	NR3500
Shopping mall: a) common access areas; b) tenanted lots; c) food area (restaurant/cafe/food court); d) lift lobby; e) corridor; f) cinema foyer; g) entertainment outlets; h) management office; i) escalator; and j) prayer room.	≥ - 80 dBm @ 95 % (coverage probability per intended coverage area)	≥ - 90 dBm @ 95 % (coverage probability per intended coverage area)	≥ - 90 dBm @ 95 % (coverage probability per intended coverage area)	≥ - 98 dBm @ 95 % (coverage probability per intended coverage area)	≥ -105 dBm @ 95 % (coverage probability per intended coverage area)

MCMC MTSFB TC G011:2023

**Table 6. GSM 1800, LTE FDD 850, LTE TDD 2300, LTE FDD 2100, LTE FDD 2600 and NR3500 P1 coverage area (continued)**

P1 coverage area	GSM 1800 (Rx Lev)	LTE FDD 850 (RSRP)	LTE TDD 2300 (RSRP)	LTE FDD 2100/2600 (RSRP)	NR3500
Office buildings: a) common access areas; b) tenanted office lots (including pantry); c) lift lobby; d) corridor; e) management office; and f) prayer room.					
Hotel: a) common access areas; b) guest rooms; c) function rooms; d) restaurant/lounge; e) lift lobby; f) clubs, spa, gymnasium and facility rooms; g) corridor; h) management office; and g) prayer room.	≥ - 80 dBm @ 95 % (coverage probability per intended coverage area)	≥ - 90 dBm @ 95 % (coverage probability per intended coverage area)	≥ - 90 dBm @ 95 % (coverage probability per intended coverage area)	≥ - 98 dBm @ 95 % (coverage probability per intended coverage area)	≥ -105 dBm @ 95 % (coverage probability per intended coverage area)
Hospitals: a) common access areas; b) clinic/consultation rooms; c) pharmacy; d) radiology and laboratory; e) patient/VVIP wards/ICU; f) operation theatre; g) function rooms; h) cafe/pantry; i) lift lobby; j) facility rooms; k) corridor; l) management office; and m) prayer room.					
Other building type: a) all public access area; and b) to be discussed with operators.	≥ - 80 dBm @ 95 % (coverage probability per intended coverage area)	≥ - 90 dBm @ 95 % (coverage probability per intended coverage area)	≥ - 90 dBm @ 95 % (coverage probability per intended coverage area)	≥ - 98 dBm @ 95 % (coverage probability per intended coverage area)	≥ -105 dBm @ 95 % (coverage probability per intended coverage area)
<p><b>NOTES:</b></p> <ol style="list-style-type: none"> <li>Deployment of coverage in these areas is recommended but final decision is subject to respective NSPs.</li> <li>For NSA 5G network, L700 will be deployed as an anchor layer to support NR3500 and the coverage will be matched for both layers.</li> <li>Any national initiative by the government will be taken into consideration.</li> <li>Deployed coverage areas for building under the National 5G Wholesale Product Network is subjected to the Access Provider agreement with the regulator.</li> </ol>					

## MCMC MTSFB TC G011:2023

**Table 7. GSM 1800, LTE FDD 850, LTE TDD 2300, LTE FDD 2100, LTE FDD 2600 and NR3500 P2 coverage area**

P2 (secondary area) coverage area	GSM 1800 (Rx Lev)	LTE FDD 850 (RSRP)	LTE TDD 2300 (RSRP)	LTE FDD 2100/2600 (RSRP)	5G NR3500
a) inside lift; b) car park (including ramps) (basement or semi open); c) cargo/baggage handling area; d) service lift; e) toilet; f) emergency staircase g) loading/unloading bay h) mechanical and electrical rooms; and i) store room.	≥ - 90 dBm @ 95 % (coverage probability per intended coverage area)	≥ - 100 dBm @ 95 % (coverage probability per intended coverage area)	≥ - 100 dBm @ 95 % (coverage probability per intended coverage area)	≥ - 105 dBm @ 95 % (coverage probability per intended coverage area)	≥ -115 dBm @ 95 % (coverage probability per intended coverage area)
<p>NOTES:</p> <ol style="list-style-type: none"> <li>1. Deployment of coverage in these areas is recommended but final decision is subject to respective NSPs and installation approval from BM.</li> <li>2. For NSA 5G network, L700 will be deployed as an anchor layer to support NR3500 and the coverage will be matched for both layers.</li> <li>3. Any national initiative by the government will be taken into consideration.</li> </ol>					

### 5.3.2.3 Coverage quality

The coverage quality is specified in Table 8.

**Table 8. Coverage quality**

Coverage area	GSM 1800 (Rx quality)	LTE FDD 850 (RSRQ and SINR)	LTE TDD 2300 (RSRQ and SINR)	LTE FDD 2100/2600 (RSRQ and SINR)	NR 3500 (RSRQ and SINR)
P1	≤ 2 @ 95% (coverage probability per intended coverage area)	≥ - 10 dB @ 95 % (coverage probability per intended coverage area)  SINR 95 % of the samples ≥ 15 dB	≥ - 10 dB @ 95 % (coverage probability per intended coverage area)  SINR 95 % of the samples ≥ 15 dB	≥ - 10 dB @ 95 % (coverage probability per intended coverage area)  SINR 95 % of the samples ≥ 15 dB	≥ - 10 dB @ 90 % (coverage probability per intended coverage area)  SINR 90 % of the samples ≥ 15 dB
P2	≤ 4 @ 95 % (coverage probability per intended coverage area)	≥ - 10 dB @ 95 % (coverage probability per intended coverage area)  SINR 95 % of the samples ≥ 10 dB	≥ - 10 dB @ 95 % (coverage probability per intended coverage area)  SINR 95 % of the samples ≥ 10 dB	≥ - 10 dB @ 95 % (coverage probability per intended coverage area)  SINR 95 % of the samples ≥ 10 dB	≥ - 10 dB @ 90 % (coverage probability per intended coverage area)  SINR 90 % of the samples ≥ 5 dB

**5.3.2.4 Installation and service performance KPI**

The following abbreviations are applied for Tables 9 and 10.

- a) BCCH is Broadcast Control Channel.
- b) PIM is Passive Intermodulation.
- c) UL is Uplink.
- d) RSSI is Receive Signal Strength Indicator
- e) TCH is Traffic Channel

For coverage area as specified previously, the IBC systems shall comply with the design criteria and requirements for installation KPI as in Table 9 and Table 10.

The IBC builder requires to discuss the test methodology with NSP before performing the test. The general testing methodologies are as follows.

- a) Walk test

Test to be done within the intended coverage area and detail route to be further discuss with NSP.

- b) Static test

Test to be done underneath antenna and location to be discuss with NSP.

The test and verification shall be done on site using standard industries approved test instrument.

**Table 9. Installation KPI**

Item	GSM 1800	LTE FDD 850	LTE TDD 2300	LTE FDD 2100/ 2600	NR 3500
Typical signal strength under every antenna (based on design)	≥ - 45 dBm @ 100 %	≥ - 45 dBm @ 100 %	≥ - 45 dBm @ 100 %	≥ - 60 dBm @ 100 %	≥ - 80 dBm @ 100 %
Signal spillage:					
a) output power;	BCCH/TCH < - 95 dBm @ 98 %	RSRP < - 110 dBm @ 90 %	RSRP < - 110 dBm @ 90 %	RSRP < - 110 dBm @ 98 %	RSRP < - 115 dBm @ 90 %
b) street level measure from building; and	10 m	10 m	10 m	10 m	10 m
c) 1st tier surrounding buildings measured for high rise implementation.	100 m - 500 m	100 m - 500 m	100 m - 500 m	100 m - 500 m	100 m - 500 m
Call setup success rate	> 98 % (tested and measured on voice call)	≥ 99 % (minimum 200 attempts on PS call)	≥ 99 % (minimum 200 attempts on PS call)	≥ 99 %	≥ 99 %

**MCMC MTSFB TC G011:2023**

**Table 9. Installation KPI (continued)**

Item	GSM 1800	LTE FDD 850	LTE TDD 2300	LTE FDD 2100/ 2600	NR 3500
Drop call rate	< 2 % (tested and measured on voice call)	≤ 1 % (minimum 200 attempts on PS call)	≤ 1 % (minimum 200 attempts on PS call)	≤ 1 %	≤ 1 %
PDP activation success rate	> 98 %	> 99 %	> 99 %	> 98 %	> 99 %
Handover success rate	> 98 % (where applicable)	> 99 % (where applicable)	> 99 % (where applicable)	> 98 % (where applicable)	> 97 % (where applicable)
VSWR	< 1.5 (feeder/jumper to antenna termination) < 1.3 (feeder point-to-point between power splitters)				
PIM	< - 150 dBc for 2 x 43 dBm inputs at combining circuit input  All measurement and testing (inclusive of frequency to be use) is to be carried out at pre-defined locations/areas agreed between the NFP and the NSP				

**Table 10. Installation KPI for Uplink (UL) Interference**

Item	GSM 1800	LTE FDD 850	LTE TDD 2300	LTE FDD 2100/2600	NR 3500
UL Interference	ICM  100 % of measurement samples categorized in Idle Channel Measurement (ICM) band 1 (unloaded)  99% of measurement samples categorized in ICM band 1 (loaded)	RSSI  ≤ - 110 dBm	RSSI  ≤ - 110 dBm	RSSI  ≤ - 110 dBm	RSSI  ≤ - 110 dBm

In the event of any failures of the KPIs, NFP and the NSP shall work together as a joint responsibility to troubleshoot. The team or trouble shooter shall isolate the DAS from the BTS to verify the root cause of failures. By the method of isolation, both NFP and the NSP can then focus on their part to troubleshoot on the issues.

## **5.2 Capacity requirement**

Capacity requirement for each NSP is different hence capacity dimensioning for IBC should be referred to and agreed by all participating NSPs for each IBC site. NSP will consider the capacity requirement of the following perspectives.

- a) The required user experience on the mobile services in terms of service loading latency and transmission quality, the user experience is determined by the characteristics of the transmitted service, the network bandwidth and End-To-End Round-Trip Time (E2E RTT).
- b) The network E2E RTT, which indicates the delay to retrieve the service from the server.
- c) The system capacity which requires the followings:
  - i) peak bandwidth per service (reflects the coverage of one service);
  - ii) average bandwidth per service; and
  - iii) network RTT.

## **6 Quality of Service (QoS) and Service Level Agreement (SLA)**

### **6.1 Mandatory standards imposed by MCMC**

Operators shall comply with all the relevant mandatory standards imposed by the Malaysian Communications and Multimedia Commission (MCMC) as follows.

- a) MCMC Determination No. 2 of 2021.
- b) MCMC Determination No. 3 of 2021.
- c) Any other relevant mandatory standard issued by MCMC from time to time.

All NSPs and Access Service Providers (ASPs) providing wireless broadband access are subject to these mandatory standards. The operators that have installed their facilities for IBC purpose shall ensure their network deployment complies with the network performance QoS, as stated in the above mandatory standards.

### **6.2 Service Level Agreement (SLA)**

The SLA includes site visit/survey arrangements, technical proposal process, installation/implementation timeline, operational maintenance requirements, fault rectification and access providers' responsibilities (see Annexes and F).

To ensure smooth implementation of the IBC, the operators and BM shall use SLAs listed in mandatory standards above as a guideline for the IBC deployment and maintenance works.

MCMC Determination No. 2 of 2021 covers SLA of site visit or survey arrangements, technical proposal process and installation or implementation timeline.

MCMC Determination No. 3 of 2021 covers SLA for fault rectification, maintenance and access providers' responsibilities.

Please refer to Annex E and Annex F for details information about SLA and service level requirements respectively.

## MCMC MTSFB TC G011:2023

### 7 Responsibility matrix

This clause highlighted on the parties/organisations involved in installing a radio communication facility inside a building. The main parties involve are specified in Table 11.

**Table 11. Parties involved in Radiocommunication Network Facilities (RNF)**

Party/organisation	Remarks
NSP	License organisation or company that provides network service to the end user
NFP	License provider or operator for any part of the RNF
BM	Owner of the building or party appointed by the building owner to manage or maintain the building

There are 2 possible scenarios in an IBC installation which are:

- a) operator/NSP is the infra owner; or
- b) NFP is the infra owner.

The responsibility matrix for operators, NFP and BM at each activity is specified in Table 12, 13, 14 and 15.

**Table 12. RNF responsibility matrix (pre-installation)**

Activity	Operators/ NFP	BM
Respond to the operators' request for site visit within 14 days of receiving written request from the operator	I	R
Provide the relevant building drawings and layout plans, if available to operators	I	R
Permit and assist operators to access the common parts of the building and In-building telecommunications system.	I	R
Make available space in the common parts and In-building telecommunications systems to the operators	I	R
Make available the combiner circuit as a POI for NSPs to connect their BTS equipment to the installed DAS.	R	
Obtain consolidated proposal which contains all the requirements of the operators who are interested to access the building		R
Acknowledge receipt of proposal and keep the operators informed of the progress from time to time	I	R
Confirm the acceptance of the proposal promptly	I	R
Give a date for commencement of installation	I	R
NOTE: I is party to be informed, R is the responsible party.		

**Table 13. RNF responsibility matrix (coordination between operators)**

Activity	Operators / NFP	BM
Appoint 1 of the operators as coordinator to liaise with the interested operators (if more than 1 operators are involved)	R	
Collect requirements from other operators who wish to access the building	R	
Arrange joint site visit and meetings	R	I
Work out consolidated proposal	R	
Co-ordinate installation work as to minimise disruption to occupiers	R	I
NOTE: I is party to be informed, R is the responsible party.		

**Table 14. RNF responsibility matrix (installation and maintenance work)**

Activity	Operators/ NFP	BM
Give access to the common parts of private building to install and maintain in-building telecommunications system	I	R
Install radio communications facilities and maintain good condition of the building	R	I
Bear the full costs of equipment and cabling facilities installation and where applicable, the costs of interconnection with the in-building telecommunications system of the building.	R	I
Pay for the electricity bill for power supply of the equipment installed in the building.	R	I
NOTE: I is party to be informed, R is the responsible party.		

**Table 15. RNF responsibility matrix (others)**

Activity	Operators/ NFP	BM
Installation should comply with all relevant regulations, guidelines, and code of practice in Malaysia	R	
Should not limit the choice of technology to be used or predetermine the access method of operators (e.g. share use of cable and facilities)		R
Appointment of license contractors or companies to install IBC. (BM should not interfere in the appointment of license contractors or companies as this could increase the cost and lead to project delay)	R	
NOTE: R is the responsible party.		

## MCMC MTSFB TC G011:2023

### Annex A (informative)

#### Abbreviation

AC	Alternating Current
ACPDB	Alternate Current Power Distribution Box
AMS	Antenna Mounting Structure
AP	Access Point
ASP	Access Service Providers
BBU	Base Band Unit
BCCH	Broadcast Control Channel
BEM	Board of Engineers Malaysia
BM	Building Management
BTS	Base Transceiver Station
BTU	Broadband Termination Unit
C&S	Civil and Structural
CAPEX	Capital Expenditure
CME	Civil, Mechanical and Electrical
CPRI	Common Public Radio Interface
DB	Distribution Box
DC	Direct Current
DIS	Digital Indoor System
E2E RTT	End-To-End Round-Trip Time
GI	Galvanized Iron
GPS	Global Positioning System
GSM	Global System for Mobile
IBC	In-Building Coverage
ICM	Idle Channel Measurement
ICU	Intensive Care Unit
IDU	Indoor Unit
IF	Intermediate Frequency
KPI	Key Performance Index
LOS	Line of Sight
LTE	Long Term Evolution
MCB	Main Circuit Breaker
MGB	Main Ground Bar
MIMO	Multiple-Input Multiple-Output
MU	Master Unit
NFP	Network Facility Provider
NR	New Radio (5G)
NSP	Network Service Provider
ODU	Outdoor Unit

## MCMC MTSFB TC G011:2023

PDU	Power Distribution Unit
PF	Power Factor
PIM	Passive Intermodulation
PoE	Power over Ethernet
PVC	Polyvinyl Chloride
QoE	Quality of Experience
QoS	Quality of Service
RF	Radio Frequency
RNF	Radiocommunication Network Facilities
RRU	Remote Radio Unit
RSRP	Reference Signal Received Power
RSRQ	Reference Signal Received Quality
RSSI	Receive Signal Strength Indicator
RU	Remote Unit
SINR	Signal to Interference & Noise Ratio
SLA	Service Level Agreement
SON	Sodium Vapour Lamp
SSO	Switch Socket Outlet
TCH	Traffic Channel
TPN	Triple Pole Neutral
UL	Uplink
VVIP	Very Very Important Person
VSWR	Voltage Standing Wave Ratio
WiFi	Wireless Fidelity

**Annex B**  
(normative)

**Combiner Specification**

The following table describe the specification for multi technology combiner.

**Table B.1. Multi technology combiner specification**

<b>Properties</b>	<b>Specification</b>
Connector type	7/16 (F) or 4.3/10 (F)
Impedance (W)	50
Insertion loss (dB)	≤ 10 (Single Band port) ≤ 7 (Multi Technology and Multi Frequency port)
VSWR	≤ 1.25
Power rating per ports (W)	≤ -100 (Single Band port) ≥ 500 (Multi Technology and Frequency Band)
PIM (dBc)	≤ -150 (Single Band port) ≤ -160 (Multi Technology and Multi Frequency port)

**Annex C**  
(normative)

**WiFi cabling configurations**

Following are the scenarios for WiFi cabling configurations.

**C.1 Scenario 1**

- a) New site
- b) Single AP (1 AP to 2 AP)
- c) Single backhaul
- d) No switch
- e) Unshielded Twisted Pair (UTP) CAT5e or CAT6 cable

NOTE: Racking will be supplied by operator. For 2 APs, switch may require.

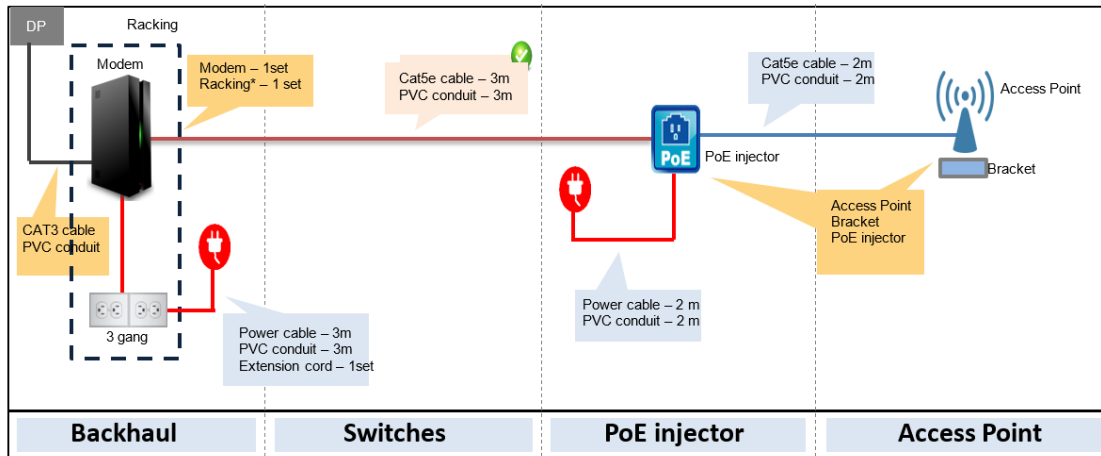

**Legend:**

- Supply by operator
- Supply by installer
- ✔ Supply by building owner

**Figure C.1. WiFi cabling configuration for scenario 1**

# MCMC MTSFB TC G011:2023

## C.2 Scenario 2

- a) New sites
- b) Multiple AP
- c) Single/multiple backhaul
- d) Switch supply by operator
- e) UTP CAT5e or CAT6 cable

NOTE: Racking will be supplied by operator.

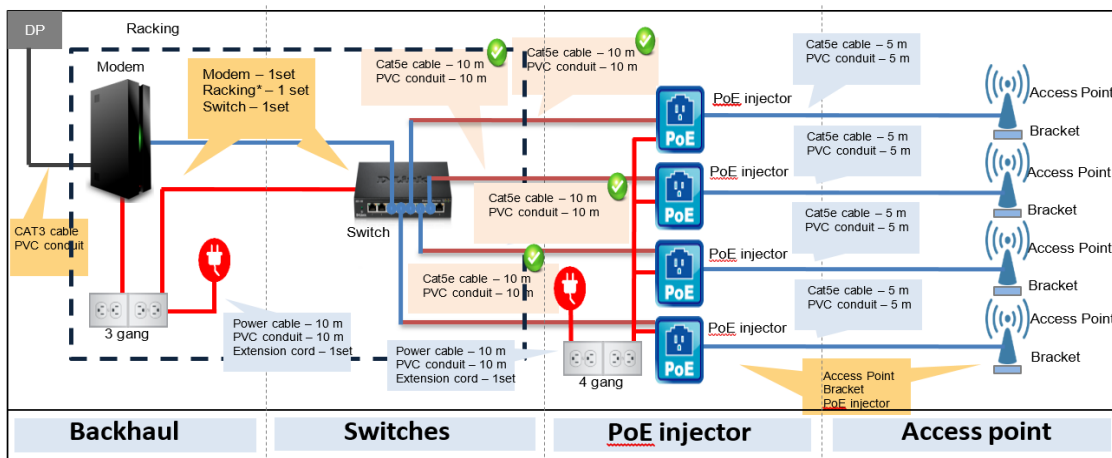

### Legend:

- Supply by operator
- Supply by installer
- Supply by building owner

Figure C.2. WiFi cabling configuration for scenario 2

**C.3 Scenario 3**

- a) New sites
- b) Multiple AP
- c) Single/multiple backhaul
- d) Switch supply by operator
- e) Combination of CAT 5e and fibre cable

NOTE: Racking will be supplied by operator.

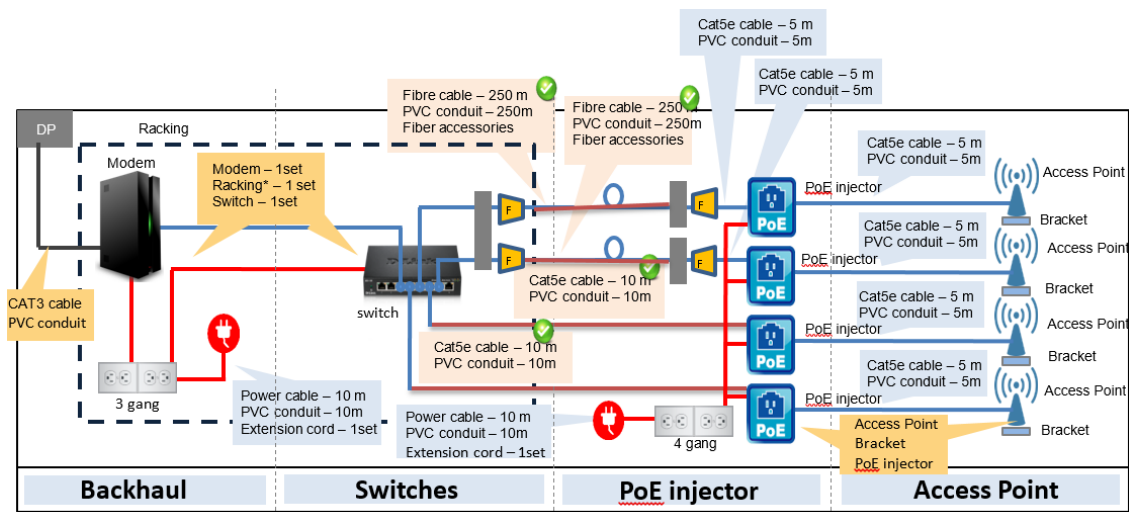

**Legend:**

- Supply by operator
- Supply by installer
- ✓ Supply by building owner

**Figure C.3. WiFi cabling configuration for scenario 3**

# MCMC MTSFB TC G011:2023

## C.4 Scenario 4

- a) New sites
- b) Multiple AP
- c) Single/multiple backhaul
- d) Switch supply by operator
- e) All fibre cables

NOTE: Racking will be supplied by operator.

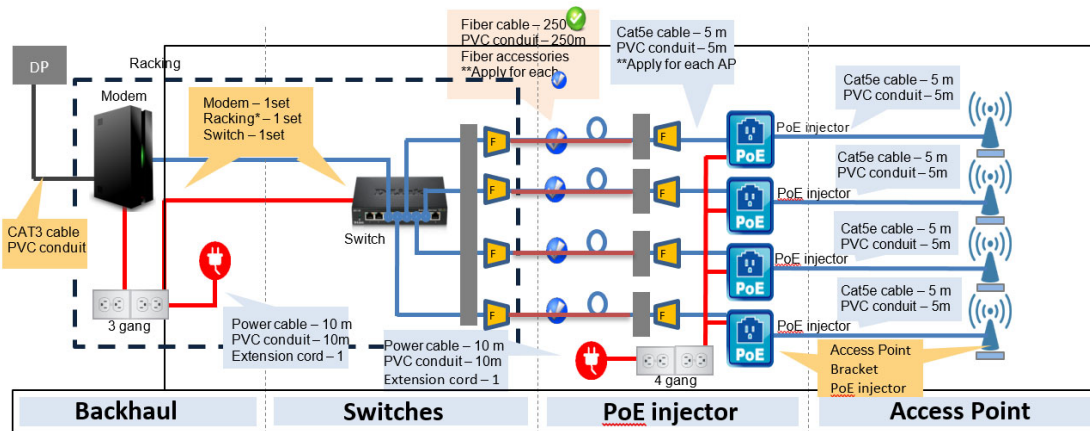

### Legend:

- Supply by operator
- Supply by installer
- ✓ Supply by building owner

Figure C.4. WiFi cabling configuration for scenario 4

**Annex D**  
(normative)

**Quality of Experience (QoE)**

The details of QoE are describe as follows.

**D.1 Capacity concept (mobile service-based data traffic estimation)**

Mobile network services are entering into the user experience oriented era, and QoE is the key for the business success. With intensive investigation samples by the industry it is identified that the network's QoE performance is related to the following four perspectives.

- a) Available network bandwidth (e.g. frequency bandwidth) for the active users.
- b) Type of service and its QoE target parameters, this will differentiate the bandwidth consumed to deliver the mobile service with the defined QoE level.
- c) Average bandwidth per service.
- d) Network E2E RTT.

Regarding the bandwidth consumed by each mobile service, it is more important to build the network capacity with good user experience, where the real-time data rate to carry one service is determined by both the network transmission quality and the characteristics of the mobile service itself.

Therefore, we will take the methodology of mobile service based data traffic estimation to evaluate the network capacity requirements. There are two important reasons to apply this methodology as follows.

- a) The mobile services in one network nowadays have changed from traditional voice-dominated traffic to packet/IP-oriented data traffic.
- b) The mobile internet provides a variety of services such as video streaming, web browsing, email and file downloading and social network sharing services.

## MCMC MTSFB TC G011:2023

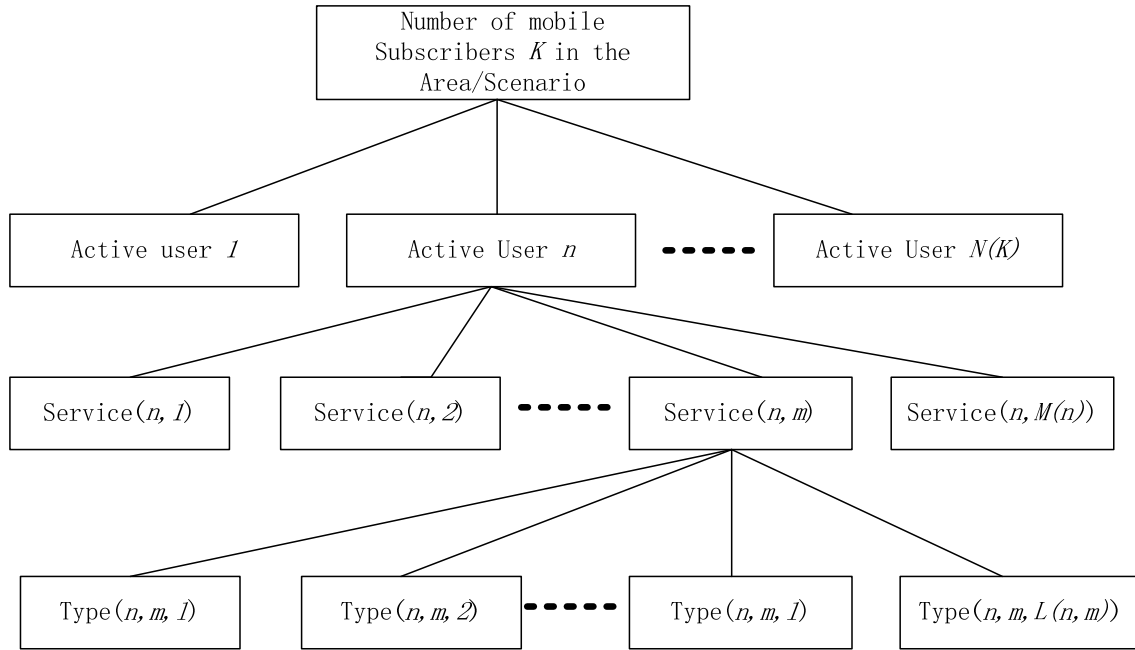

**Figure D.1. Mobile service-based network capacity estimation**

The data traffic in the network is the accumulation of the data traffic contributed by each mobile service.

Data Traffic (Throughput<sub>network</sub>) in the network (or one scenario area in the network)

$$\text{Throughput}_{\text{network/area}} = \sum_{n=1}^{N(K)} \sum_{m=1}^{M(n)} \sum_{l=1}^{L(n,m)} \text{Data Rate}_{\text{service type } n,m,l}$$

where,

$K$  Number of one network mobile subscribers in the specified scenario or area;

$N(K)$  Number of active users out of the  $K$  subscribers;

$M(n)$  Number of concurrent services by one active user with index  $n$ ;

$L(n,m)$  Type of services by one service  $m$  for active user  $n$ ;

According to the above equation, the following parameters will determine one scenario/area's network data traffic.

- The number of subscriber's  $K$  in the area or scenario.
- The number of active users  $N(K)$  out of the total  $K$  subscribers.
- The mobile services running concurrently on all the active users.
- The bandwidth consumed by each type of mobile service (e.g. video streaming with different resolution and quality, video 720P/1080P/2K/4K/8K).

**D.2 Capacity evaluation (steps to evaluate one network throughput)**

With all the discussions above, the steps to evaluate one network throughput are as following.

- a) Determine the number of concurrent active users in the network for each RAT. Generally, it is done by getting the statistics of the Active User Ratio (AUR) in the target Scenario when the network is fully loaded at busy hours.

$$N(K) = K * AUR_x \quad (AUR \text{ at busy hours for each RAT } )$$

- b) Identify the mobile services running for all the active users. Generally, it is done by getting the statistics of the Concurrent Service Ratio (CSR) in the target Scenario when the network is fully loaded at Busy Hours (BH).

$$CSR_{BH} = \begin{cases} C2_{\{n,s,t\}} & (CSR_{2G}) \\ C4_{\{n,s,t\}} & (CSR_{4G}) \\ C5_{\{n,s,t\}} & (CSR_{5G}) \end{cases}$$

It should be noticed that, in order to utilize the 2G/4G/5G networks efficiently with best ROI, currently most of the voice service is running on 2G network, (acceptable) low-rate and low latency high data rate services are working on 4G/4.5/5G networks.

$$\# \text{ of (virtual) active users by RAT} = \# \text{ of mobile subscribers} * AR_{\{rat\}} * CSR_{BH}$$

- c) Calculate the accumulated data rate requirement by 4G and 5G, each RAT, for all the mobile services. Please notice that 2G network will be mainly used to afford voice services for QoE reasons. This result will be the Throughput offered by the network in the scenario.

$$\text{Throughput}_{area,4G} = \sum_{n,4G} \sum_s \sum_t Data \ Rate_{service \ type \ n,s,t}$$

$$\text{Throughput}_{area,5G} = \sum_{n,5G} \sum_s \sum_t Data \ Rate_{service \ type \ n,s,t}$$

- d) Calculate the required network capacity required, which means # of cells for each RAT.

$$\# \text{ of } 2G \text{ Cells} = Ceil\{ \# \text{ of mobile subscribers} * AUR_{2G} * 1.0 * \frac{\sum_s Active \ Voice \ Service}{2G \ Cell \ Capacity} \}$$

$$\# \text{ of } 4G \text{ Cells} = Ceil\{ \# \text{ of mobile subscribers} * AUR_{4G} * \frac{\sum_s \sum_t CSR_{BH,4G} * data \ rate_{4G \ service}}{4G \ Cell \ Capacity} \}$$

$$\# \text{ of } 5G \text{ Cells} = Ceil\{ \# \text{ of mobile subscribers} * AUR_{5G} * \frac{\sum_s \sum_t CSR_{BH,5G} * data \ rate_{5G \ service}}{5G \ Cell \ Capacity} \}$$

Actually, the following part is the average data rate for 4G and 5G subscribers.

$$Average \ data \ rate \ per \ User = \sum_s \sum_t CSR_{BH,4G} * data \ rate_{4G \ service}$$

**Annex E**  
(normative)

**Service Level Agreement (SLA)**

The SLA is a timeline specification for various tasks undertaken by the responsible party or parties. The service provider and the user shall enter into an agreement with these specified timelines which are deemed reasonable for the particular service level agreed upon. Non-compliance may or may not involve penalties to the aggrieved party.

**Table E.1. Site visit or survey arrangements SLA**

No	Task/item	SLA duration (maximum)
1.	Notice by the operators to BM to visit the site.	5 working days
2.	Response by BM to the operators for site visit.	5 working days
3.	Timeline for the operators to perform site survey or signal measurement.	7 working days

**Table E.2. Technical proposal process SLA**

No	Task/item	SLA duration (maximum)
1.	Technical proposal submission by the operators to BM.	21 working days
2.	Technical proposal approval by BM.	14 working days
3.	Site securing by the operators upon technical proposal approval by BM.	21 working days

**Table E.3. Installation or implementation timeline SLA**

No	Task/item	SLA duration (maximum)
1.	Pre-construction briefing by the operators to BM.	1 calendar day
2.	Pre-construction inspection by the operators with BM. Any defects that would disrupt and hinder the installation works shall be submitted with proof of photos and description of defects to BM.	1 calendar day
3.	Estimated installation timeline according to number of antennas:  a) > 100 antennas. b) > 200 antennas. c) > 300 antennas. d) > 500 antennas.  NOTE: The above estimation is based on a minimum requirement of 4 teams per building. Each team consisting of 3 personnel. This is inclusive of any make good works performed by the operators due to installation of antenna feeder system on the building.	5 weeks 9 weeks 13 weeks 21 weeks

**Table E.3. Installation or implementation timeline SLA** *(continued)*

No	Task/item	SLA duration (maximum)
4.	Measurement walk test performed by the operators to verify the signal coverage and quality levels. This is inclusive of any signal optimisation works performed by the operators for site acceptance.	7 calendar days
5.	Joint inspection by the operators with BM on the final installation quality.	2 calendar days
6.	Approval of IBC build quality by BM.	1 calendar day
7.	Site declared “ready for service” by the operators.	1 calendar day

**Annex F**  
(normative)

**Service level requirements**

Following are the list of specific requirements under the SLA.

**F.1 Service level agreement (fault rectification)**

**Table F.1. Service level agreement (fault rectification)**

Severity	Call back	Remedy	Performance fulfilment	Restoration	Report time (Prelim.)	Root cause analysis (Final)	Remarks
Critical	< 15 minutes	2 hours	99.99 %	< 1 calendar days			Impact to all services affecting all operators
Major	< 30 minutes	3 hours	99.99 %	< 3 calendar days			Impact to certain services affecting all operators
Minor	< 10 minutes	3 calendar days	99.99 %	< 14 calendar days			N/A

Root cause analysis means lead time from the restoration of the problem to the submission of the report as follows.

- a) 99.9 % availability;
- b) Response and resolution related to service provider's systems which includes:
  - i) outages;
  - ii) alarms;
  - iii) performance issues (refer 2G KPI, 4G KPI and 5G KPI sheets); and
- c) Fault escalation process.

Examples of severity are as follows.

- a) Critical (total coverage down on all technologies, AC power outage, backhaul outage, etc.).
- b) Major (high temperature, partial coverage loss, sector down, DAS related performance issues (refer to KPI sheets), etc).
- c) Minor (non-service impacting alarms/conditions).

**F.2 Maintenance**

The maintenance requirements shall be as follows.

- a) Spares commitment (5 years minimum) at 10 % level of all critical components/modules.
- b) NMS for the active DAS with all major alarms extended to operators.
- c) Regular system monitoring report (monthly report recommended).
- d) Regular walk test report for individual local NSP (once every 6 months recommended).
- e) Others, basic (open-contact) alarm points for power outage and high-temperature made available to all operators.

**F.3 Access provider's responsibility**

The responsibility of access provider shall be as follows.

- a) To provide operators with 24/7 access to the telecommunication room, RRU, GPS (rooftop) locations for maintenance.
- b) To provide approval or coordination for any equipment upgrading or swapping when required.
- c) To assist operators to access all covered area when required by operator to perform walk test and for other purpose.
- d) To provides support personnel during walk tests when any operators receive customer complains on faults with DAS associated possibility of faults.

**Bibliography**

- [1] ETSI 300 019-1, *Environmental Engineering (EE); Environmental conditions and environmental tests for telecommunications equipment*

## **Acknowledgements**

### **Members of the Radiocommunications Network Facilities (Internal) Sub-Working Group**

Mr Mohammad Nur Syafiq Aziz (Chair/Draft Lead)	Digi Telecommunications Sdn Bhd
Mr Mohamad Norzamir Mat Taib/	Malaysian Technical Standards Forum Bhd
Mr Muhaimin Mat Salleh (Secretariat)	
Mr Rohaizad Embong/	Celcom Axiata Berhad
Mr Saiful Irwan Mohd Yusoff/	
Ms Sofiah Nazli Zakaria	
Ms Laavenia Ramasegar	Digi Telecommunications Sdn Bhd
Dr Ainnur Eiza Azhar/	Digital Nasional Berhad
Ms Manisha Hanifah/	
Mr Muhammad Firdaus Rosidi/	
Mr Nagaintheran Seluarize/	
Mr Ting Siew Chuan	
Ms Irma Syafrida Abd Majid/	edotco Malaysia Sdn Bhd
Mr Juhasli Aizi Juperi/	
Mr Mohamad Yazid Mohamad/	
Mr Mohammad Hairris Azwar Johari/	
Mr Sani Azrul Mohamad Salleh	
Dr Khairayu Badron	International Islamic University Malaysia
Ms Ang Su Yuong/	Maxis Broadband Sdn Bhd
Mr Eami Yusry Mohd Yusof/	
Mr Muhammad Amiri Idris/	
Mr Rakuram Gandhi	
Mr Muhammad Zafir Zamani/	Telekom Malaysia Berhad
Mr Najib Fadil Mohd Bisri @ Bisri/	
Ms Nurul Ain Mohd Najib	
Mr David Lim Teck Huat/	U Mobile Sdn Bhd
Mr Kuan Kok Wai/	
Mr Lo Phua Kian/	
Mr Mohd Zulkamal Othman	
Mr Mohd Zakwan Nazmi Mohd Zaim/	Webe Digital Sdn Bhd
Ms Siti Najwa Muhammad	
Mr Deepak Dhiman	YTL Communications Sdn Bhd

### **By invitation:**

Mr Chong Chee Wah	Ericsson (M) Sdn Bhd
-------------------	----------------------